

HISTORY INFORMATION FOR THE FOLLOWING MANUAL:

SERVICE MANUAL

RA-6A CHASSIS

<u>MODEL NAME</u>	<u>REMOTE COMMANDER</u>	<u>DESTINATION</u>	<u>CHASSIS NO.</u>
KP-46WT510	RM-Y909	US/CND	SCC-M10DA

ORIGINAL MANUAL ISSUE DATE: 6/2003

 : UPDATED ITEM

REVISION DATE	SUBJECT
6/2003	No revisions or updates are applicable at this time.
6/30/2003	Updated G (Pg. 58) and D (Pg. 77) Schematics, Added critical symbol to G Board on Exploded View section 6-3. Chassis (Pg. 90) Updated critical components on Parts Lists (Pgs. 92-135)
8/25/2003	Updated Table of Contents (Pg. 3) Corrected Diagrams for H2, H1, and H4 Board Removal (Pg. 11) Replaced 2-11. Service Data Lists with 2-11. Adjustable Service Data Lists (Replace Pgs. 19-37 with Pgs. 19-29) Corrected procedures for 2-12. Registration Adjustment (Replace Pg. 38 with Pg. 30) Corrected procedures for 2-13-2. Copying All Registration Data to Other Modes and 2-14. Auto Registration Offsets (Replace Pg. 42 with Pg. 34) Corrected Error Codes 54 & 55, 2-15. Auto Registration Error Codes (Replace Pg. 43 with Pg. 35) Added 2-16. Auto Registration Diagnostics (Replace Pg. 44 with Pg. 36) Corrected 3-D-Comb # from 5-3. Block Diagram (Replace Pg. 51 with Pg. 43) Deleted IC308 Block Diagram from 5-5. IC Block Diagrams (Replace Pg. 84 with Pg. 76) Corrected semiconductors 5-6. Semiconductors (Replace Pg. 88 with Pg. 80) Corrected Grille piece on cover exploded view diagrams (Replace Pg. 89 with Pg. 81)
11/11/2003	Replaced data relating to CR, CG and CB Boards. Affects Pages 46-48 (Schematics), 83 (Exploded View), 84-87 (Parts List).
11/16/2004	Removed Note from section 2-12-1. Setup For Adjustment. Note is intended for use by the factory during production, and should not be performed by service technicians.(Pg. 30) Updated A Board, Complete PN, Added A Board, Mounted PN, Added New CRT's, D Board, introduced new S/N range. Affects S/N's 8,000,001 to 8,700,000 (Pg. 82 & 83)
11/17/2004	Added new D Board PN to Electircal Parts List Affects S/N's 8,000,001 to 8,700,000 (Pg. 120 & 124)
8/19/2005	Updated serial number range for D Boards and CRTs (Pg. 82, 83, and 120)

COLOR REAR VIDEO PROJECTION

SONY®

SERVICE MANUAL

RA-6A CHASSIS

<u>MODEL NAME</u>	<u>REMOTE COMMANDER</u>	<u>DESTINATION</u>	<u>CHASSIS NO.</u>
KP-46WT510	RM-Y909	US/CND	SCC-M10DA



KP-46WT510



RM-Y909

COLOR REAR VIDEO PROJECTION

SONY®

TABLE OF CONTENTS

SECTION TITLE	PAGE	SECTION TITLE	PAGE
Specifications	4	SECTION 5: DIAGRAMS.....	41
Warnings and Cautions	5	5-1. Circuit Boards Location	41
Safety Check-Out	6	5-2. Printed Wiring Boards and Schematic Diagrams Information	41
Self-Diagnostic Function.....	7	5-3. Block Diagrams	43
SECTION 1: DISASSEMBLY.....	10	5-4. Schematics and Supporting Information	46
1-1. Rear Board Removal.....	10	CR Board Schematic Diagram	46
1-2. Chassis Assembly Removal.....	10	CB Board Schematic Diagram	47
1-3. Service Position	10	CG Board Schematic Diagram	48
1-4. H2 Board Removal.....	11	V Board Schematic Diagram	49
1-5. H1 Board Removal.....	11	G Board Schematic Diagram	50
1-6. H4 Board Removal.....	11	UD Board Schematic Diagram	52
1-7. Mirror Cover Removal	12	A Board Schematic Diagram (1 of 3).....	54
1-8. Beznets Assembly Removal	12	A Board Schematic Diagram (2 of 3).....	55
1-9. SR Board Removal	12	A Board Schematic Diagram (3 of 3).....	56
1-10. AD Board and B Board Removal	12	AD Board Schematic Diagram	60
1-11. G Board Removal.....	13	U Board Schematic Diagram	62
1-12. Terminal Board, A Board, D Board, U Board, and UD Board Removal	13	B Board Schematic Diagram (1 of 2)	65
1-13. Picture Tube Removal.....	14	B Board Schematic Diagram (2 of 2)	66
1-14. High-Voltage Cable Installation and Removal.....	14	D Board Schematic Diagram.....	69
SECTION 2: SET-UP ADJUSTMENTS.....	15	SR Board Schematic Diagram	72
2-1. Screen Voltage Adjustment (Coarse Adjustment)	15	H2 Board Schematic Diagram	72
2-2. Screen (G2) Adjustment (Fine Adjustment).....	15	H1 Board Schematic Diagram	74
2-3. Deflection Yoke Tilt Adjustment	15	H4 Board Schematic Diagram	75
2-4. Focus Lens Adjustment.....	16	5-5. IC Block Diagrams	76
2-5. Focus VR Adjustment.....	16	A Board	76
2-6. 2-Pole Magnet and Centering Magnet Adjustment	17	B Board	77
2-7. Centering Magnet Adjustment.....	17	CR Board	78
2-8. 4-Pole Magnet Adjustment	17	CG Board	78
2-9. Blue Defocus Adjustment	17	CB Board.....	78
2-10. Electrical Adjustments by Remote Commander.....	18	U Board.....	79
2-11. Adjustable Service Data Lists	19	5-6. Semiconductors	80
2-12. Registration Adjustment	30	SECTION 6: EXPLODED VIEWS.....	81
2-13. PJE Adjustment (Sub Deflection Adjustment)	32	6-1. Cover.....	81
2-14. Auto Registration Offsets	34	6-2. Chassis	82
2-15. Auto Registration Error Codes	35	6-3. Picture Tube	83
2-16. Auto Registration Diagnostics	36	SECTION 7: ELECTRICAL PARTS LIST.....	84
SECTION 3: SAFETY-RELATED ADJUSTMENTS.....	37		
D BOARD	37		
3-1. HV Regulation Circuit Check and Adjustment	37		
3-2. HV Hold Down Circuit Operation Check and Adjustment	37		
G BOARD	38		
3-3. +B Max Voltage Confirmation	38		
3-4. +B OVP Confirmation.....	38		
SECTION 4: CIRCUIT ADJUSTMENTS.....	39		
4-1. Blue Offset Adjustment.....	39		
4-2. P & P Sub Contrast Adjustment (Video) (SCON)	39		
4-3. P & P Sub Contrast Adjustment (RF) (SCON)	39		
4-4. P & P Sub-Hue and Sub-Color Adjustment (Video) (SHUE, SCOL)	39		
4-5. P & P Sub-Hue and Sub-Color Adjustment (RF) (SHUE, SCOL).....	40		

SPECIFICATIONS

Power Requirements 120V AC, 60Hz

Power Consumption (W)

In Use (Max) 230W

In Standby Under 1 W

Inputs/Outputs DVI-HDTV

1 terminal, 3.3V T.M.D.S., 50 ohms
The DVI-HDTV input terminal is compliant with the EIA-861 standard and is not intended for use with personal computers.

Video (IN)

4 total (1 on front panel)
1Vp-p, 75ohms unbalanced, sync negative

S Video (IN)

3 total (1 on front panel)
Y: 1Vp-p, 75ohms unbalanced, sync negative
C: 0.286Vp-p (Burst signal), 75ohms

Audio (IN)

6 total (1 on front panel)
500 mVrms (100% modulation)
Impedance:47 kilo ohms

Audio (VAR/RIX)

1 total
500 mVrms at the maximum volume setting (Variable)
500 mVrms (Fixed)
Impedance (Output):1 kilo ohm

TV Out

1 total
Video: 1 Vp-p 75 ohms unbalanced, Sync negative
Audio: 500 m Vrms (100% modulation)
Impedance (output): 1 kilo ohms

Control S (IN/OUT)

1 total
Minijacks

Component Video Input

2 (Y, P_B, P_R)
Y: 1.0 Vp-p, 75 ohms unbalanced, sync negative
P_B: 0.7 Vp-p, 75 ohms;
P_R: 0.7 Vp-p, 75 ohms

RF Inputs

2 total

Converter

1 total

	KP-46WT510
Speaker Output (W)	20W x 2
Dimensions (W x H x D)	
mm	1086 x 1017 x 609 mm
in	42 ^{3/4} x 40 x 24 in
Mass	
kg	61.3 kg
lbs	135 lbs

Projection System

3 picture tubes, 3 lenses, horizontal in-line system

Screen Size (measured diagonally)

46 inches

Picture Tube

7-inch high-brightness monochrome tubes (6.3 raster size), with optical coupling and liquid cooling system.

Supplied Accessories

Remote Control RM-Y909
Batteries (2) size AA (R6)

Projection Lenses

High performance, large diameter hybrid lens F1.1

Optional Accessories

A/V Cable (VMC-810/820/830 HG)
Audio Cable (RKC-515HG)
Component Video Cable (VMC-10/30 HG)
Control S Cable (RK-G69HG)
AV Receiver (STR-V555ES or equivalent)
TV Stand SU-46WT5

Antenna

75 ohm external terminal for VHF/UHF

Television System

NTSC, American TV Standard

Channel Coverage

VHF: 2-13/ UHF: 14-69/ CATV: 1-125

WARNINGS AND CAUTIONS

CAUTION

Short circuit the anode of the picture tube and the anode cap to the metal chassis, CRT shield, or carbon painted on the CRT, after removing the anode.

WARNING!!

An isolation transformer should be used during any service to avoid possible shock hazard, because of live chassis. The chassis of this receiver is directly connected to the ac power line.

SAFETY-RELATED COMPONENT WARNING!!

Components identified by shading and  mark on the schematic diagrams, exploded views, and in the parts list are critical for safe operation. Replace these components with Sony parts whose part numbers appear as shown in this manual or in supplements published by Sony. Circuit adjustments that are critical for safe operation are identified in this manual. Follow these procedures whenever critical components are replaced or improper operation is suspected.

ATTENTION!!

Après avoir déconnecté le cap de l'anode, court-circuiter l'anode du tube cathodique et celui de l'anode du cap au châssis métallique de l'appareil, ou la couche de carbone peinte sur le tube cathodique ou au blindage du tube cathodique.

Afin d'éviter tout risque d'électrocution provenant d'un châssis sous tension, un transformateur d'isolement doit être utilisé lors de tout dépannage. Le châssis de ce récepteur est directement raccordé à l'alimentation du secteur.

ATTENTION AUX COMPOSANTS RELATIFS A LA SECURITE!!

Les composants identifiés par une trame et par une marque  sur les schémas de principe, les vues explosées et les listes de pièces sont d'une importance critique pour la sécurité du fonctionnement. Ne les remplacer que par des composants Sony dont le numéro de pièce est indiqué dans le présent manuel ou dans des suppléments publiés par Sony. Les réglages de circuit dont l'importance est critique pour la sécurité du fonctionnement sont identifiés dans le présent manuel. Suivre ces procédures lors de chaque remplacement de composants critiques, ou lorsqu'un mauvais fonctionnement suspecte.

SAFETY CHECK-OUT

After correcting the original service problem, perform the following safety checks before releasing the set to the customer:

1. Check the area of your repair for unsoldered or poorly soldered connections. Check the entire board surface for solder splashes and bridges.
2. Check the interboard wiring to ensure that no wires are "pinched" or touching high-wattage resistors.
3. Check that all control knobs, shields, covers, ground straps, and mounting hardware have been replaced. Be absolutely certain that you have replaced all the insulators.
4. Look for unauthorized replacement parts, particularly transistors, that were installed during a previous repair. Point them out to the customer and recommend their replacement.
5. Look for parts which, though functioning, show obvious signs of deterioration. Point them out to the customer and recommend their replacement.
6. Check the line cords for cracks and abrasion. Recommend the replacement of any such line cord to the customer.
7. Check the B+ and HV to see if they are specified values. Make sure your instruments are accurate; be suspicious of your HV meter if sets always have low HV.
8. Check the antenna terminals, metal trim, "metallized" knobs, screws, and all other exposed metal parts for AC leakage. Check leakage as described below.

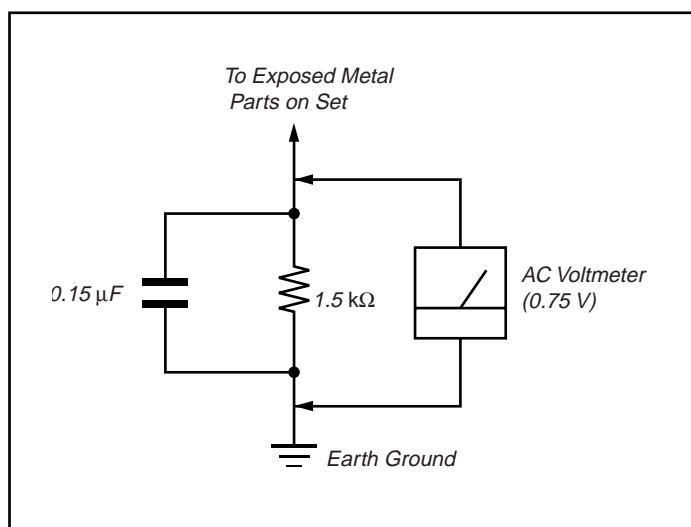

Figure A. Using an AC voltmeter to check AC leakage.

Leakage Test

The AC leakage from any exposed metal part to earth ground and from all exposed metal parts to any exposed metal part having a return to chassis, must not exceed 0.5 mA (500 microamperes). Leakage current can be measured by any one of three methods.

1. A commercial leakage tester, such as the Simpson 229 or RCA WT-540A. Follow the manufacturers' instructions to use these instructions.
2. A battery-operated AC milliammeter. The Data Precision 245 digital multimeter is suitable for this job.
3. Measuring the voltage drop across a resistor by means of a VOM or battery-operated AC voltmeter. The "limit" indication is 0.75 V, so analog meters must have an accurate low voltage scale. The Simpson's 250 and Sanwa SH-63TRD are examples of passive VOMs that are suitable. Nearly all battery-operated digital multimeters that have a 2 VAC range are suitable (see Figure A).

How to Find a Good Earth Ground

A cold-water pipe is a guaranteed earth ground; the cover-plate retaining screw on most AC outlet boxes is also at earth ground. If the retaining screw is to be used as your earth ground, verify that it is at ground by measuring the resistance between it and a cold-water pipe with an ohmmeter. The reading should be zero ohms.

If a cold-water pipe is not accessible, connect a 60- to 100-watt trouble-light (not a neon lamp) between the hot side of the receptacle and the retaining screw. Try both slots, if necessary, to locate the hot side on the line; the lamp should light at normal brilliance if the screw is at ground potential (see Figure B).

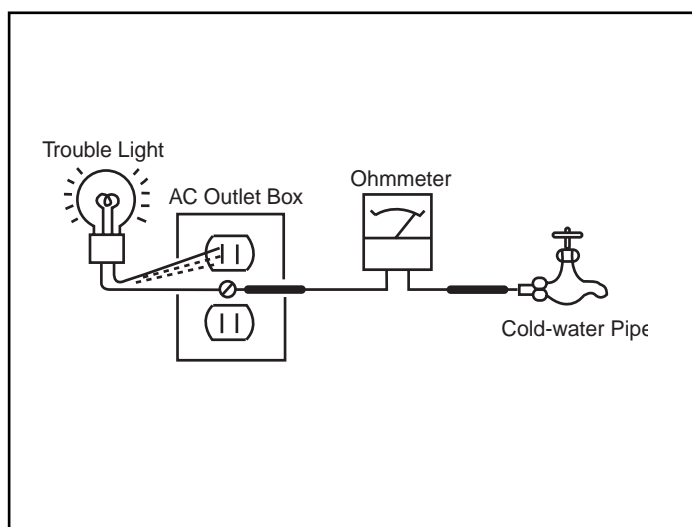

Figure B. Checking for earth ground.

SELF-DIAGNOSTIC FUNCTION



The units in this manual contain a self-diagnostic function. If an error occurs, the STANDBY/TIMER LED will automatically begin to flash. The number of times the LED flashes translates to a probable source of the problem. A definition of the STANDBY/TIMER LED flash indicators is listed in the instruction manual for the user's knowledge and reference. If an error symptom cannot be reproduced, the Remote Commander can be used to review the failure occurrence data stored in memory to reveal past problems and how often these problems occur.

Diagnostic Test Indicators

When an error occurs, the STANDBY/TIMER LED will flash a set number of times to indicate the possible cause of the problem. If there is more than one error, the LED will identify the first of the problem areas.

Results for all of the following diagnostic items are displayed on screen. If the screen displays a "0", no error has occurred.

Diagnostic Item	No. of times STAND BY / TIMER lamp flashes	Probable Cause Location	Detected Symptoms
Power does not turn on	Does not light	<ul style="list-style-type: none"> Power cord is not plugged in. Fuse is burned out (F6001). (G Board) 	<ul style="list-style-type: none"> Power does not come on. No power is supplied to the TV. AC Power supply is faulty.
+B overcurrent (OCP)*	2 times	<ul style="list-style-type: none"> H.OUT (Q8024) is shorted. (D Board) +B PWM (Q8035, Q8038) is shorted. (D Board) 	<ul style="list-style-type: none"> Power does not come on. Load on power line shorted.
+B overvoltage (OVP)	3 times	<ul style="list-style-type: none"> IC501 is faulty. (G Board) IC5002 is faulty. (G Board) 	<ul style="list-style-type: none"> Has entered standby mode.
Vertical deflection stopped	4 times	<ul style="list-style-type: none"> ±15V is not supplied. (D Board) IC8003 is faulty. (A Board) 	<ul style="list-style-type: none"> Has entered standby state after horizontal raster. Vertical deflection pulse is stopped. Power line is shorted, or power supply is stopped.
White Balance Failure (Not Balanced)	5 times	<ul style="list-style-type: none"> Video OUT (IC7101, IC7201, IC7301) is faulty. (CR, CG, CB Boards) CRT drive (IC309) is faulty. (A Board) Screen (G2) is improperly adjusted. ** 	<ul style="list-style-type: none"> No raster is generated. CRT Cathode current detection reference pulse output is small.
Low B OCP/OVP (Overcurrent/Overvoltage) ***	6 times	<ul style="list-style-type: none"> +5 line is overloaded. (A, B Boards) +5 line is shorted. (A, B Boards) 	<ul style="list-style-type: none"> No picture
Horizontal deflection stopped	7 times	<ul style="list-style-type: none"> Q8035, Q8038 is shorted. (D Board) 	
High-voltage error	8 times	<ul style="list-style-type: none"> T8005 is faulty. (D Board) 	
Audio error	9 times	<ul style="list-style-type: none"> ± 19V line is shorted. (A, B Boards) IC708 is faulty. (A Board) PS701 or PS702 is opened. (A Board) 	<ul style="list-style-type: none"> No sound

* If a +B overcurrent is detected, stoppage of the vertical deflection is detected simultaneously. The symptom that is diagnosed first by the microcontroller is displayed on the screen.

** Refer to Screen (G2) Adjustments in Section 2-2 of this manual

*** If TIMER or STAND BY indicator blinks six (6) times, unplug the unit and wait 10 minutes before performing the adjustment.

Display of Standby/Timer LED Flash Count

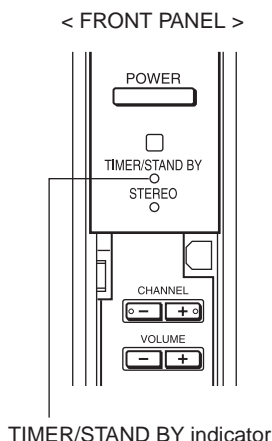

* One blink is not used for self-diagnosis.

• EXAMPLE

<Diagnosis Items> <Number of Blinks>

- +B overcurrent 2 times
- +B overvoltage 3 times
- Vertical deflection stop 4 times

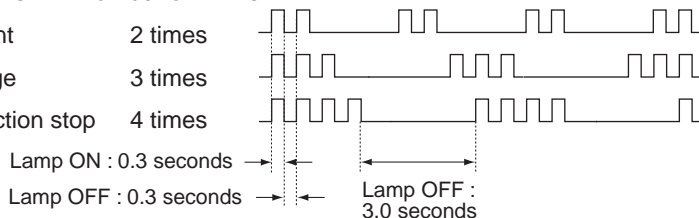

Release of TIMER STAND BY indicator blinking

The TIMER/STANDBY indicator blinking display is released by turning OFF the power switch on the TV main unit or removing the plug from the power.

Self-Diagnosis Screen Displays

In cases of malfunctions where it is not possible to determine the symptom such as when the power goes off occasionally or when the screen disappears occasionally, there is a screen display on whether the malfunction occurred or not in the past (and whether the detection circuit operated or not) in order to allow confirmation.

Screen Display Method

Quickly press the remote command button in the following order from the standby state.

[Display] → Channel [5] → Sound Volume* [0] → Power ON

SELF DIAGNOSIS	
2 : +B OCP	N/A
3 : +B OVP	N/A
4 : V STOP	0
5 : AKB	1
10 : WDT	24

*Note that this differs from entering the service mode (sound volume [4])

Numeral "0" means that no fault was detected.

Numeral "1" means a fault was detected one time or more

Self-Diagnosis Screen Display

The results display is not automatically cleared. In case of repairs and after repairs, check the self-diagnosis screen and be sure to return the results display to "0".

If the results display is not returned to "0" it will not be possible to judge a new malfunction after completing repairs.

Method of Clearing Results Display

1. Power off (Set to the standby mode.)
2. [Display] → Channel [5] → Sound Volume [4] → Power ON (Service Mode)
3. Channel [8] → [ENTER] (Test reset = Factory preset condition)

Method of Ending Self Diagnosis Screen

When ending the self-diagnosis screen completely, turn the power switch OFF on the remote commander or the main unit.

Self-Diagnosis Function Operation

- OCP** Low B and +B line detect DET SHORT, and shut-down POWER ON RELAY.
Reset by turning power on/off. In case of +B is loaded approx. 1.5A or more, microcomputer detects it via IC5005.
- OVP** In case of +B becomes approx. 150V or more, POWER ON RELAY shuts down and microcomputer detects it via IC5005.
Reset by turning power on/off just the same as OCP.
- Low B** Occurs when set +5V is out
- V Stop** In the case of the V Drive disappearing, Q8001 detects it and shuts-down the POWER ON RELAY. The microcomputer detects it and causes the LED to blink.
- AKB** IK detection. Makes LED blink when microcomputer doesn't detect IK, returns of IC309 (CXA2150AQ) 20 seconds or more.
- H Stop** In case H DRIVE disappears, Q378 detects it and shuts-down POWER ON RELAY. Microcomputer receives H Stop data from Q378 and makes the LED blink.
- HV Stop** In case HV becomes 33kV or more, IC8006 detects it and shuts-down POWER ON RELAY. The microcomputer makes the LED blink.
- Audio** In case of DC component overlaps the output of Audio Amp., the microcomputer detects it and shuts-down POWER ON RELAY. The microcomputer makes the LED blink.

Self-Diagnosis Block Diagram

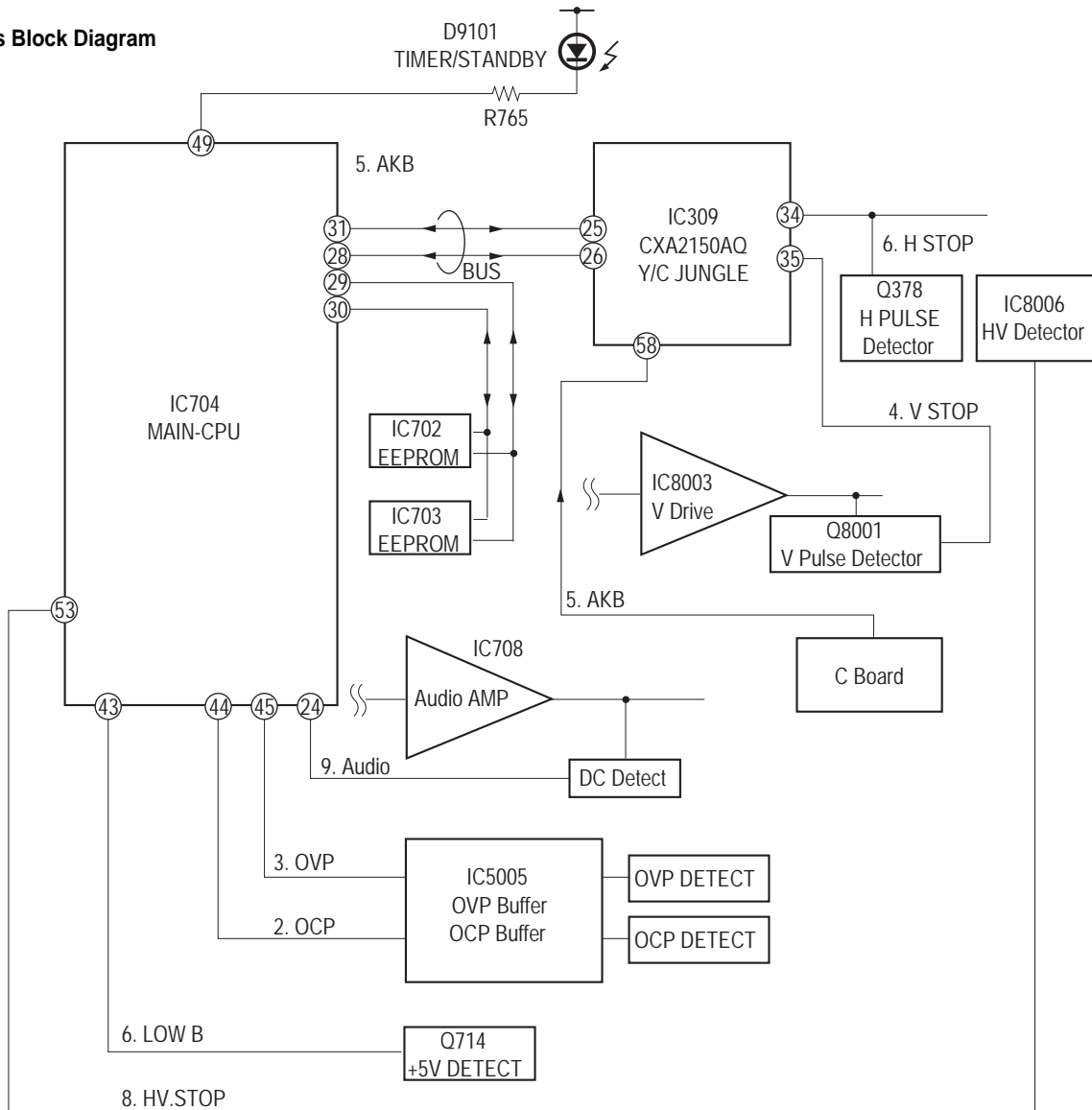

SECTION 1: DISASSEMBLY

1-1. REAR BOARD REMOVAL

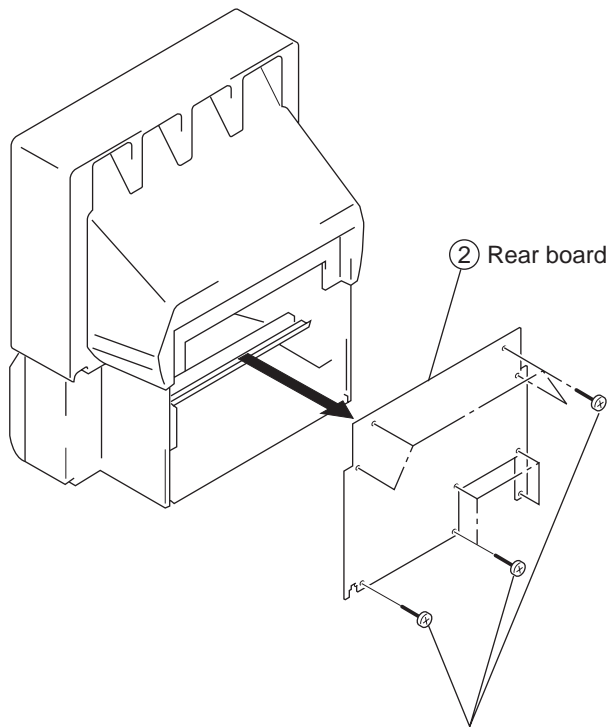

① Nine Screws, dome washer
HEX tap 4 x 20

1-2. CHASSIS ASSEMBY REMOVAL

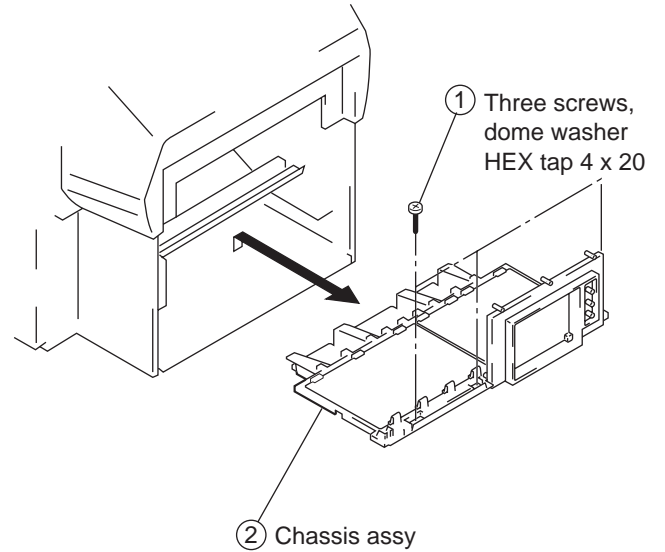

1-3. SERVICE POSITION

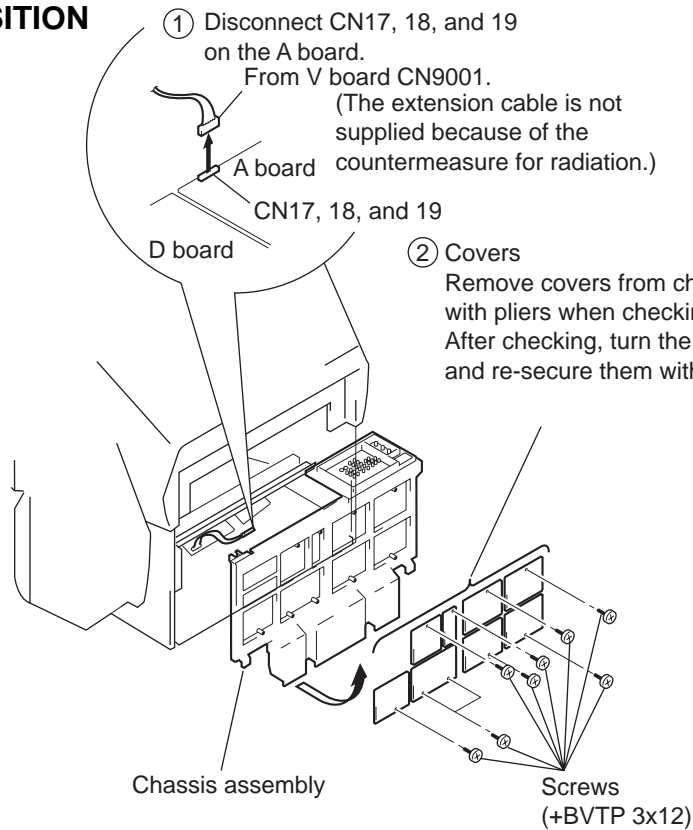

1-4. H2 BOARD REMOVAL

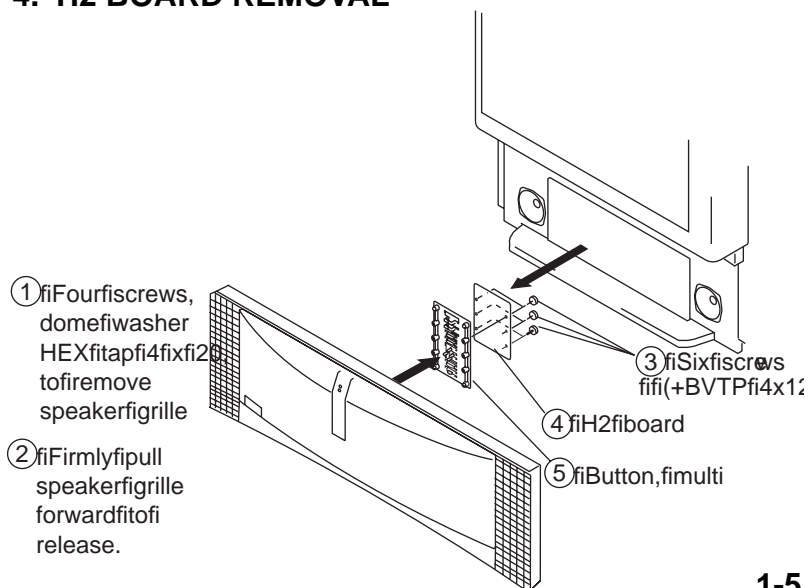

1-5. H1 BOARD REMOVAL

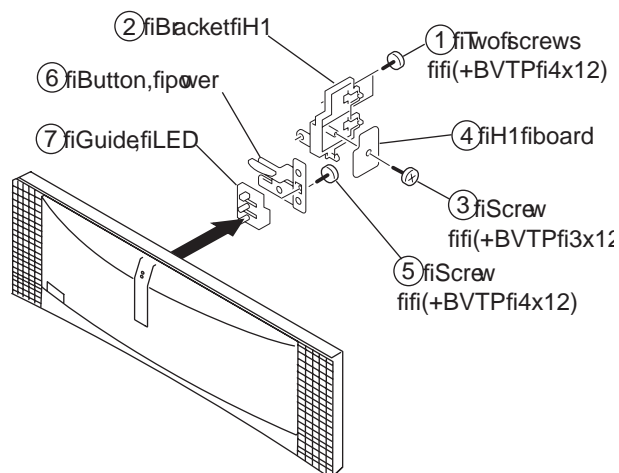

1-6. H4 BOARD REMOVAL

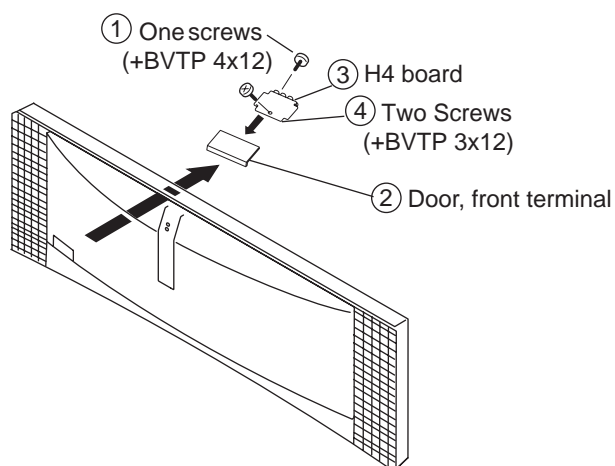

1-7. MIRROR COVER REMOVAL

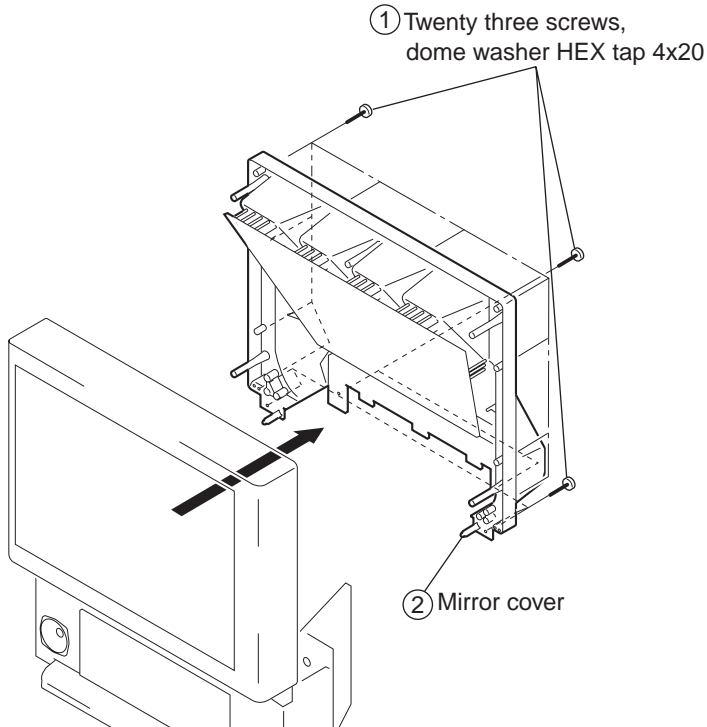

1-8. BEZNET ASSEMBLY REMOVAL

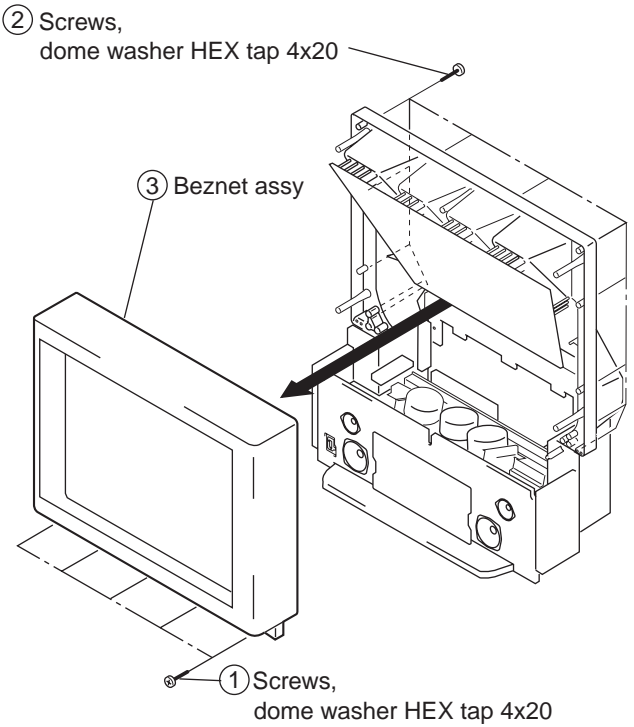

1-9. SR BOARD REMOVAL

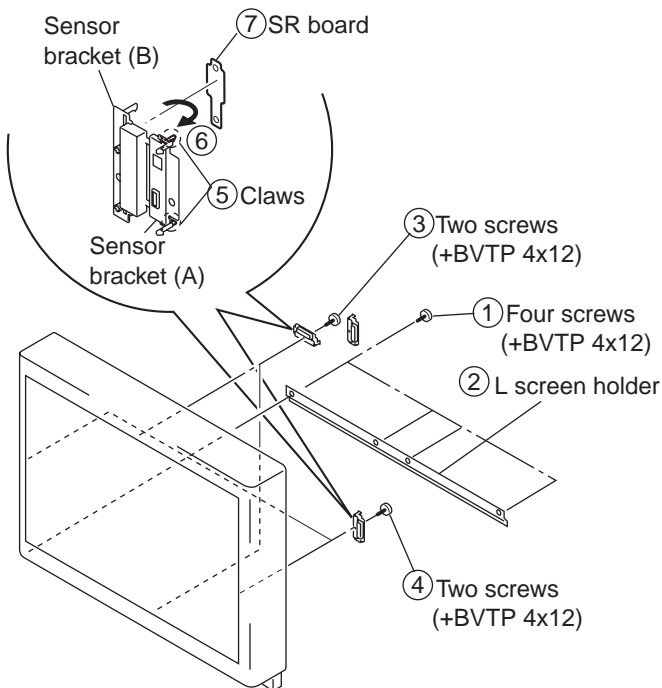

1-10. AD BOARD AND B BOARD REMOVAL

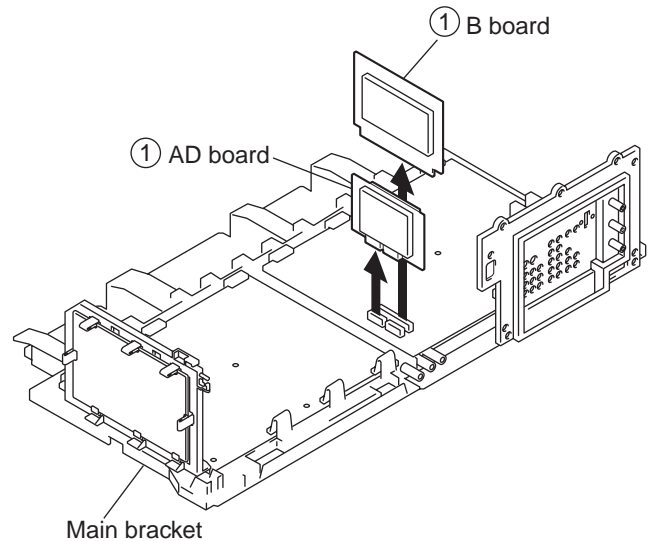

1-11.G BOARD REMOVAL

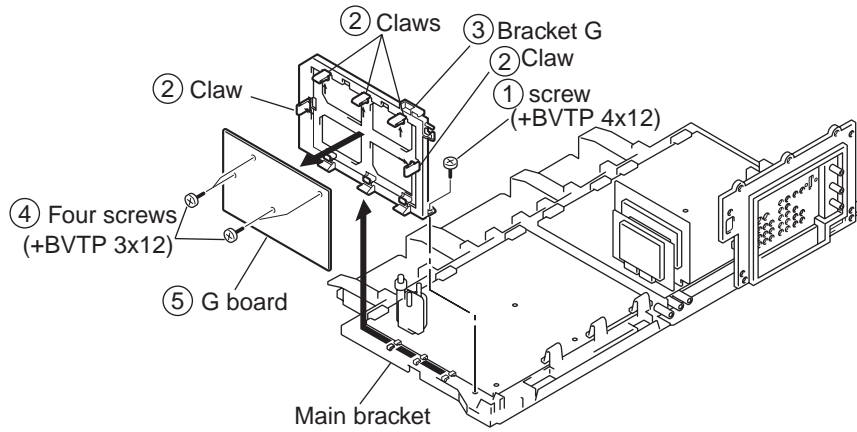

1-12. TERMINAL BOARD, A BOARD, D BOARD, U BOARD, AND UD BOARD REMOVAL

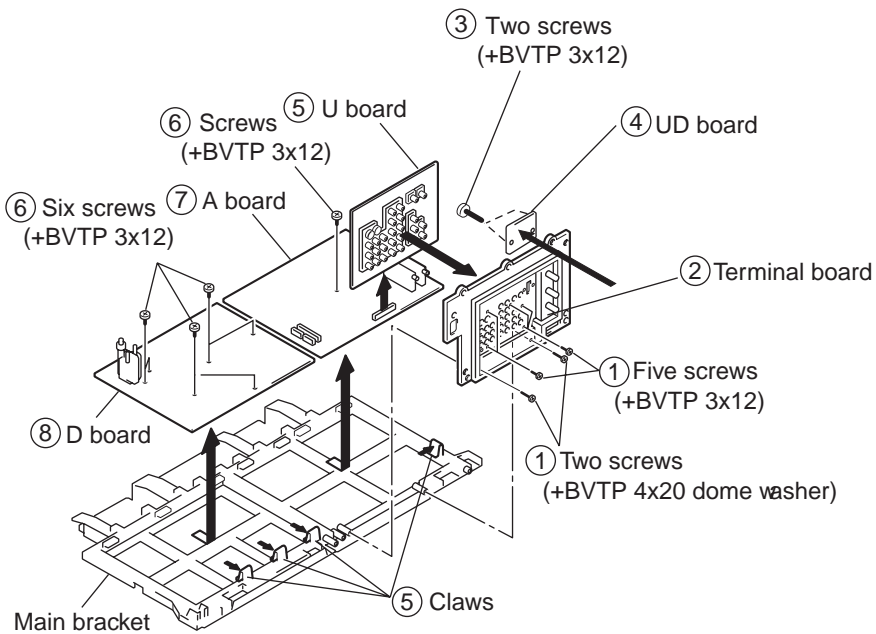

1-13.PICTURE TUBE REMOVAL

CAUTION Removing the arrow-marked screws is strictly prohibited. If removed, it may cause liquid spill.

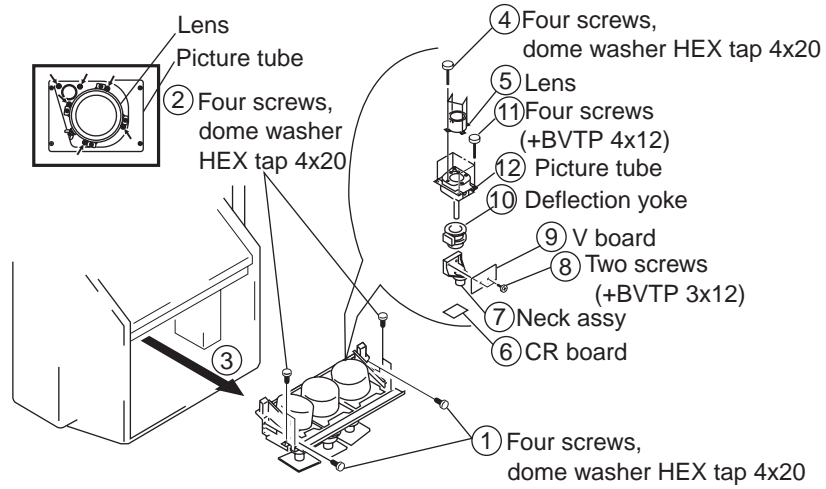

1-14.HIGH-VOLTAGE CABLE INSTALLATION AND REMOVAL

(1) Removal

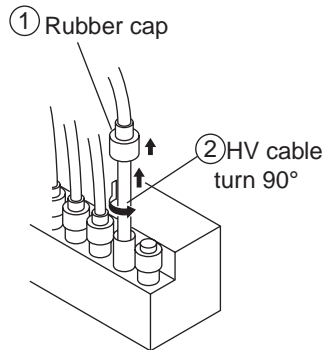

(2) Installation

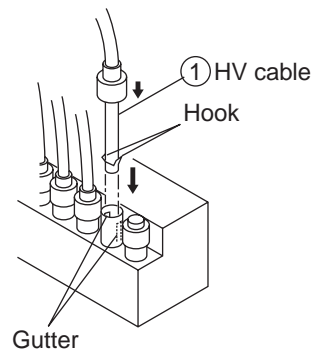

SECTION 2: SET-UP ADJUSTMENTS

2-1. SCREEN VOLTAGE ADJUSTMENT (COARSE ADJUSTMENT)

1. Receive the Monoscope signal.
2. Set BRIGHTNESS to 50% and PICTURE to minimum.
3. Turn the red VR on the focus block all the way to the left and then gradually turn it to the right until the retrace line is barely visible.
4. Gradually turn the control to the left until the retrace line disappears.

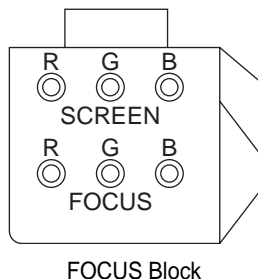

2-2. SCREEN (G2) ADJUSTMENT (FINE ADJUSTMENT)

If the jig described below is available, it is recommended that the G2 Fine Mode Adjustment be performed to set the screen controls to their optimal condition. If desired, you can build the jig illustrated below, using 3-watt resistors. Please note that if the proper voltage is not obtained with the listed resistor's values, then increase or decrease one of the values in the resistor network to obtain the correct voltage.

1. Select VIDEO-1 mode no signal applied (the screen must be black).
2. Connect the G2 JIG.
3. SW on JIG.
4. Connect an oscilloscope to the TP7101(KR), TP7202(KG) and TP7301(KB) of CR board, CG board, and CB board.
5. Adjust red, green, and blue screen voltage to 177.5+/-0.5V with screen VR on the focus block.

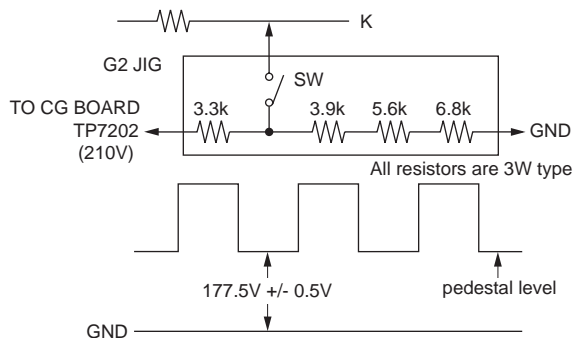

2-3. DEFLECTION YOKE TILT ADJUSTMENT

1. Connect the color bar generator monoscope pattern to Video 1 input.
2. Cover the red and blue CRT lenses with lens caps to allow only green to show (or use the method shown in the note below for turning off the CRTs individually without using lens caps).
3. Loosen the CRT's deflection yoke set screw and align the tilt of the deflection yoke so that the horizontal bars at the center of the monoscope pattern are horizontal.
4. After aligning the deflection yoke fasten it securely to the funnel-shaped portion (neck) of the CRT.
The tilt of the deflection yoke is aligned in the mode.
5. Cover the green and blue CRT lenses with lens caps to allow only green to show (or use the method shown in the note below for turning off the CRTs individually without using lens caps), then repeat steps 3 and 4 for the red CRT.
Cover the green and red CRT lenses with lens caps to allow only green to show (or use the method shown in the note below for turning off the CRTs individually without using lens caps), then repeat steps 3 and 4 for the blue CRT.

Note: If lens caps are unavailable, you can cut off the unnecessary color beams by controlling the service mode 2150P-2 1 RGBS.

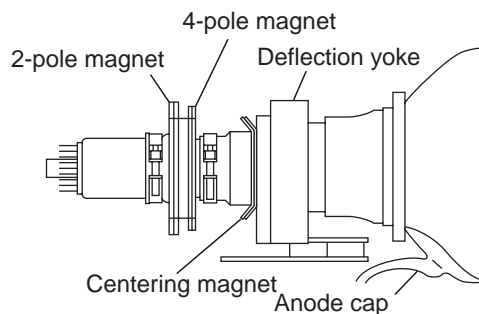

2-4. FOCUS LENS ADJUSTMENT

In this adjustment, use the remote commander while in service mode. For details on the usage of the service mode and the remote commander, please refer to section

2-10. ELECTRICAL ADJUSTMENTS BY REMOTE COMMANDER.

1. Loosen the lens screw.
2. Cover the red and blue CRT lenses with lens caps to allow only green to show (or use the method shown in the note below for turning off the CRTs individually without using lens caps).
3. Turn the green lens to adjust to the optimum focus point with the crosshatch signal.
4. Tighten the lens screw.
5. Cover the green and blue CRT lenses with the lens caps to allow only red to show (or use the method shown in the note below for turning off the CRTs individually without using lens caps).
6. Turn the red lens to adjust to the optimum focus point with the crosshatch signal.
7. Tighten the lens screw.
8. Cover the green and red CRT lenses with the lens caps to allow only blue to show (or use the method shown in the note below for turning off the CRTs individually without using lens caps).
9. Turn the blue lens to adjust to the optimum focus point with the crosshatch signal.
10. Tighten the lens screw.
11. After adjusting the items:
 2-5. FOCUS VR ADJUSTMENT,
 2-6. 2-POLE MAGNET ADJUSTMENT,
 2-8. 4-POLE MAGNET ADJUSTMENT,
 Reconfirm the optimum focus point and adjust again if necessary.

* Every time 6 is pressed, the test signal changes to:
 "crosshatch+video signal" → "crosshatch+borderline (black)" →
 "crosshatch (black)" → "dots (black)" → off

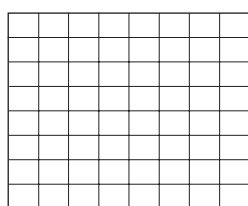

Test Signal

Note: If lens caps are unavailable, you can cut off the unnecessary color beams by controlling the service mode 2150P-2 1 RGBS.

2-5. FOCUS VR ADJUSTMENT

1. Set generator to crosshatch.
2. Cover the red and blue CRT lenses with lens caps to allow only green to show (or use the method shown in the note below for turning off the CRTs individually without using lens caps).
3. Turn the green focus VR on the focus block to adjust to the optimum focus point with the crosshatch signal.
4. Cover the green and blue picture lenses with lens caps to allow only red to show (or use the method shown in the note below for turning off the CRTs individually without using lens caps).
5. Turn the red focus VR on the focus block to adjust to the optimum focus point with the crosshatch signal.
6. Cover the green and red picture lenses with lens caps to allow only blue to show (or use the method shown in the note below for turning off the CRTs individually without using lens caps).
7. Turn the blue focus VR on the focus block to adjust to the optimum focus point with the crosshatch signal.
8. After adjusting the items:
 2-4. FOCUS LENS ADJUSTMENT,
 2-6. 2-POLE MAGNET AND CENTERING ADJUSTMENT,
 2-8. 4-POLE MAGNET ADJUSTMENT,
 Reconfirm the optimum focus point and adjust again if necessary.

Note: If lens caps are unavailable, you can cut off the unnecessary color beams by controlling the service mode 2150P-2 1 RGBS.

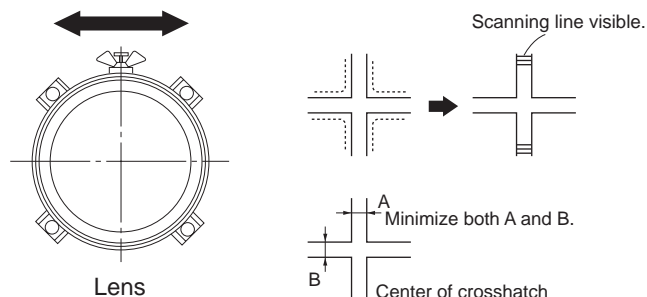

2-6. 2-POLE MAGNET AND CENTERING MAGNET ADJUSTMENT

1. Set the picture mode to PRO and picture to MAX.
2. Either select the PJED Test Pattern dot hatch signal or apply an external dot signal.
3. Cover the red and blue CRT lenses with lens caps to allow only green to show (or use the method shown in the note below for turning off the CRTs individually without using lens caps).
4. Turn the focus VR on the focus block to the left (counter clockwise) and set it to overfocus to enlarge the spot.
5. Adjust the CRT's 2-pole magnet so that the small bright spot is in the center.
6. Align the focus VR on the focus block and set it for the best focus.
7. Apply a Monoscope signal to the set.
8. Adjust the H-CENTERING and V-CENTERING roughly by the centering magnets.
9. Check 2-pole magnet adjustment. If necessary repeat steps 1-6.
10. Repeat steps 1 through 9 for the red CRT covering the green and blue CRT lenses with lens caps to allow only red to show (or use the method shown in the note below for turning off the CRTs individually without using lens caps) and adjust the red focus control on the focus block.
11. Repeat steps 1 through 9 for the blue CRT covering the red and green CRT lenses with lens caps to allow only blue to show (or use the method shown in the note below for turning off the CRTs individually without using lens caps) and adjust the blue focus control on the focus block.

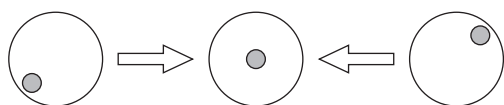

Note: If lens caps are unavailable, you can cut off the unnecessary color beams by controlling the service mode 2150P-2 1 RGBS.

2-7. CENTERING MAGNET ADJUSTMENT

Not required - Combined with 2-6 2-Pole And Centering Magnet Adjustment.

2-8. 4-POLE MAGNET ADJUSTMENT

1. Set the picture mode to PRO and picture to MAX.
2. Receive the Dot signal.
3. Cover the red and blue CRT lenses with lens caps to allow only green to show (or use the method shown in the note below for turning off the CRTs individually without using lens caps).
4. Turn the (green) focus VR on the focus block to the right (clockwise) and set it to under-focus to reduce the spot.
5. Adjust the 4-pole magnet so that the small spot in the center of the screen becomes round for green and red.
6. Adjust the blue spot to an oval shape X:Y=1:1.2

Note: If lens caps are unavailable, you can cut off the unnecessary color beams by controlling the service mode 2150P-2 1 RGBS.

Use the center dot

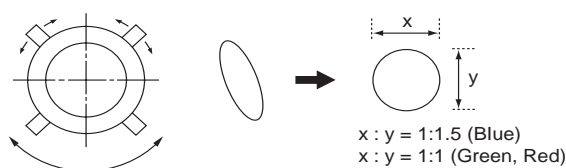

2-9. BLUE DEFOCUS ADJUSTMENT

1. Setup: Apply a Dot Hatch Signal and set the mode to Pro Mode. Change the color temperature to Cool in the user's menu.
2. Cover the red and green CRT lenses with lens caps to allow only blue to show (or use the method shown in the note below for turning off the CRTs individually without using lens caps).
4. Turn the blue focus VR on the focus block to the right (clockwise) to make the round dot oval.

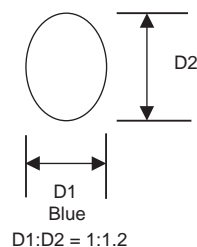

5. Check the flare with a high luminance signal to make sure the flare is minimal while the bright spot is located in the center, If not, readjust the 2 and 4-pole magnets.
6. Check for uniformity on a 100% IRE to an all white signal.

Note: If lens caps are unavailable, you can cut off the unnecessary color beams by controlling the service mode 2150P-2 1 RGBS.

2-10.ELECTRICAL ADJUSTMENTS BY REMOTE COMMANDER

All of the circuit adjustments can be made by using the remote commander (RM-Y909).

NOTE : The following test equipment is required:

1. Pattern Generator (with component outputs)
2. Frequency counter
3. Digital multimeter
4. Audio oscillator

2-10-1.METHOD OF ENTERING THE SERVICE ADJUSTMENT MODE

SERVICE MODE PROCEDURE

1. TV must be in Standby mode. (Power off)
2. Press "DISPLAY", "5", "VOL +", then "POWER" on the remote commander.
(Press each button within 1 second of pressing the previous button.)

SERVICE MODE ADJUSTMENT

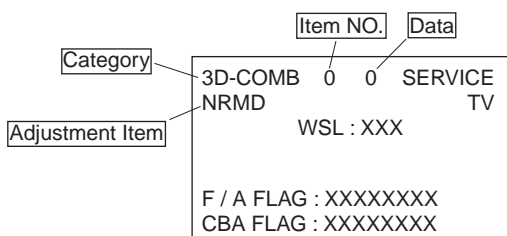

3. The screen displays the item being adjusted within that category.
4. Press 1 or 4 on the remote commander to select the adjustment item.
5. Press 3 or 6 on the remote commander to change the data.
6. Press 2 or 5 on the remote commander to select the adjustment category.

Every time you press 2 (Category up), service mode changes in the order shown below:

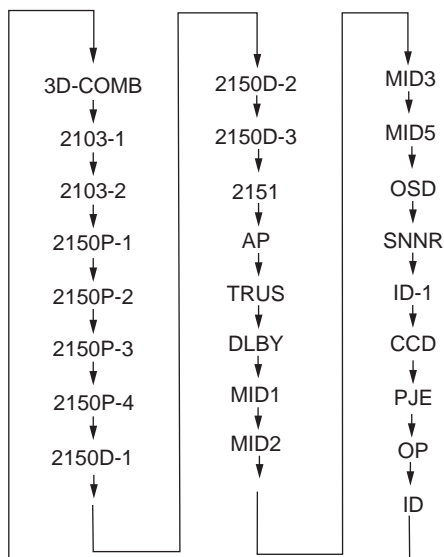

7. If you want to go back to the most recently saved value, press "0" then "ENTER" to read the memory.

8. Press "MUTING" then "ENTER" to write the new adjustment data into memory.
9. When you want to exit the service mode, turn the power off.

Note: Press "8" then "ENTER" on the remote commander to restore the factory settings for user controls and channel memories (this will also turn set off and then on to exit the service mode).

2-10-2.MEMORY WRITE CONFIRMATION METHOD

1. After adjustment, turn the power off with the remote commander.
2. Turn the power ON and set to service mode.
3. Cycle through the adjusted items again and confirm that the adjustments were saved.

2-10-3.ADJUSTING BUTTONS AND INDICATOR

Note: When the PJE mode (which displays an internally generated signal) is activated, several buttons on the remote commander will have different functions than the ones listed below. Therefore, when in the PJE mode, refer to section 2-12-3 for button functions.

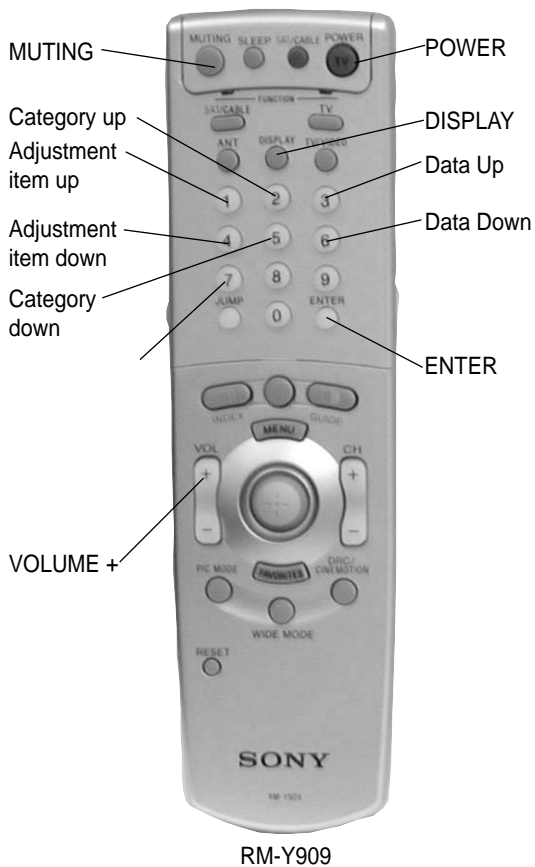

2-11.AJUSTABLE SERVICE DATA LISTS

Only the Adjustable registers are shown in the initial data list.

A complete set of the Initial data, Fixed and Adjustable, can be downloaded at: http://www-ec.sdp.sel.sony.com/padics/Model_Data_List.htm
 Initial data is also available in an Excel format.

CATEGORY	#	ITEM	DESCRIPTION	CONDITION	46WT510	MIN	MAX	+ = Unsigned - = Signed	
C2103_1	2	SCON	Sub contrast	RF	7	0	15	+	[0: GA, 1: US, 2: Europe]
				Video 1-4	7	0	15	+	
	3	SCOL	Sub color	RF	7	0	15	+	
				Video 1-4	7	0	15	+	
	4	SHUE	Sub hue	RF	7	0	15	+	
				Video 1-4	7	0	15	+	
	20	CBOF	Cb Offset Adjustment	P&P Left M-DRC Video1-4	34	0	63	+	
				P&P Left M-DRC Video5,6 480i	34	0	63	+	
	21	CROF	Cr Offset Adjustment	P&P Left M-DRC Video1-4	32	0	63	+	
				P&P Left M-DRC Video5,6 480i	32	0	63	+	
C2103_2	2	SCON	Sub contrast	RF	7	0	15	+	
				Video1-4	7	0	15	+	
	3	SCOL	Sub color	RF	7	0	15	+	
				Video1-4	7	0	15	+	
	4	SHUE	Sub hue	RF	7	0	15	+	
				Video1-4	7	0	15	+	
	20	CBOF	Cb Offset Adjustment	P&P Right S-DRC RF/Video1-4	32	0	63	+	
				P&P Right S-DRC Video5,6,7 480i	32	0	63	+	
	21	CROF	Cr Offset Adjustment	P&P Right S-DRC RF/Video1-4	31	0	63	+	
				P&P Right S-DRC Video5,6,7 480i	31	0	63	+	
C2150P_1	4	SBRT	Sub Bright	Common	24	0	63	+	(lower byte) (upper byte)
	5	RDRV	R output drive	Common	31	0	63	+	
	7	BDRV	B output drive	Common	31	0	63	+	
	8	RCUT	R output cutoff	Common	31	0	63	+	
	10	BCUT	B output cutoff	Common	31	0	63	+	
C2150D_1	0	VPOS	Vertical position(V_DRV signal DC bias)	Common	27	0	63	+	
	1	VSIZ	V_SIZE:Vertical size(V_DRV signal gain)	Common	50	0	63	+	
	2	VSZO	V_SIZE OFFSET	1080i	23	0	63	+	
C2150D_2	2	HSIZ	H_SIZE:Horizontal size	Wide Zoom	35	0	63	+	
				Full/Normal/Zoom	35	0	63	+	
	3	SLIN	MP_PARA_DC:Horizontal S-correction	Wide Zoom	0	0	15	+	
				Full/Normal/Zoom	0	0	15	+	
OSD	0	HPOS	OSD horizontal position	Common	18	0	255	+	
	1	HPOF	Horizontal position for Favorite mode	Common	32	0	255	+	
CCD	0	HPRM	Horizontal position of CCD(Main)	Common	49	0	255	+	▲6: 1130→1110
	1	HPRS	Horizontal position of CCD(Sub)	Common	49	0	255	+	

ADJUSTABLE SERVICE DATA LISTS

CATEGORY	#	ITEM	DESCRIPTION	CONDITION	46WT510	MIN	MAX	+ = Unsigned - = Signed	
PJE	29	ROGH	Green Horizontal Sensor 0 Ratio Offset	(common)	0	-128	127	-	
	30	RORH	Red Horizontal Sensor 0 Ratio Offset	(common)	0	-128	127	-	
	31	ROBH	Blue Horizontal Sensor 0 Ratio Offset	(common)	0	-128	127	-	
	32	R1GH	Green Horizontal Sensor 1 Ratio Offset	(common)	0	-128	127	-	
	33	R1RH	Red Horizontal Sensor 1 Ratio Offset	(common)	0	-128	127	-	
	34	R1BH	Blue Horizontal Sensor 1 Ratio Offset	(common)	0	-128	127	-	
	35	R1GV	Green Vertical Sensor 1 Ratio Offset	(common)	0	-128	127	-	
	36	R1RV	Red Vertical Sensor 1 Ratio Offset	(common)	0	-128	127	-	
	37	R1BV	Blue Vertical Sensor 1 Ratio Offset	(common)	0	-128	127	-	
	38	R2GH	Green Horizontal Sensor 2 Ratio Offset	(common)	0	-128	127	-	
	39	R2RH	Red Horizontal Sensor 2 Ratio Offset	(common)	0	-128	127	-	
	40	R2BH	Blue Horizontal Sensor 2 Ratio Offset	(common)	0	-128	127	-	
	41	R2GV	Green Vertical Sensor 2 Ratio Offset	(common)	0	-128	127	-	
	42	R2RV	Red Vertical Sensor 2 Ratio Offset	(common)	0	-128	127	-	
	43	R2BV	Blue Vertical Sensor 2 Ratio Offset	(common)	0	-128	127	-	
	44	R3GH	Green Horizontal Sensor 3 Ratio Offset	(common)	0	-128	127	-	
	45	R3RH	Red Horizontal Sensor 3 Ratio Offset	(common)	0	-128	127	-	(upper byte)
	46	R3BH	Blue Horizontal Sensor 3 Ratio Offset	(common)	0	-128	127	-	(lower byte)
	47	PTRH	Red Horiz Top Pattern Position Offset	(common)	0	-128	127	-	
	48	PTBH	Blue Horiz Top Pattern Position Offset	(common)	0	-128	127	-	
	49	PLRH	Red Horiz Left Pattern Position Offset	(common)	0	-128	127	-	
	50	PLBH	Blue Horiz Left Pattern Position Offset	(common)	0	-128	127	-	
	51	PLRV	Red Vertical Left Pattern Position Offset	(common)	0	-128	127	-	
	52	PLBV	Blue Vertical Left Pattern Position Offset	(common)	0	-128	127	-	
	53	PRRH	Red Horiz Right Pattern Position Offset	(common)	0	-128	127	-	
	54	PRBH	Blue Horiz Right Pattern Pos Offset	(common)	0	-128	127	-	
	55	PRGH	Green Vertical Right Pattern Pos Offset	(common)	0	-128	127	-	
	56	PRRV	Red Vertical Right Pattern Pos Offset	(common)	0	-128	127	-	
	57	PRBV	Blue Vertical Right Pattern Pos Offset	(common)	0	-128	127	-	
	58	PBGH	Green Horiz Bottom Pattern Pos Offset	(common)	0	-128	127	-	
	59	PBRH	Red Horiz Bottom Pattern Pos Offset	(common)	0	-128	127	-	
	60	PBBH	Blue Horiz Bottom Pattern Pos Offset	(common)	0	-128	127	-	

ADJUSTABLE SERVICE DATA LISTS

CATEGORY	#	ITEM	DESCRIPTION	CONDITION	46WT510	MIN	MAX	+ = Unsigned - = Signed
PJE	61	ERR	Auto Regi. Error code	(common)	0	0	65535	+
	66	VUP	Sensor 0 Green Vertical Pattern Position	(common)	41	0	2047	+
	67	VMID	Sensor 1 Green Vertical Pattern Position	(common)	505	0	2047	+
	68	VLOW	Sensor 3 Green Vertical Pattern Position	(common)	971	0	2047	+
	69	HLE	Sensor 1 Green Horizontal Pattern Position	(common)	55	0	4095	+
	70	HMID	Sensor 0 Green Horizontal Pattern Position	(common)	636	0	4095	+
	71	HRIV	Sensor 2 Green Horizontal Pattern Position	(common)	1217	0	4095	+
	72	TEST	Auto Regi. Test Item	(common)				
	73	SFTF	Fast motion of burn prevention switch	(common)				
	74	SFTE	CRT burn prevention enable	(common)	0	0	7	+
	75	ACTL	Account timer counter lower byte	(common)	7	0	255	+
	76	ACTH	Account timer counter upper byte	(common)	0	0	255	+
	77	ATTN	Auto Regi attenuation select	(common)	0	0	3	+

ADJUSTABLE SERVICE DATA LISTS

CATEGORY	#	ITEM	DESCRIPTION	CONDITION	46WT510	MIN	MAX	+ = Unsigned - = Signed	
PJE		CENT	R H Cent	Full / Normal	35	-512	511	-	
				Zoom / V.Comp	35	-512	511	-	
				WideZoom	35	-512	511	-	
				1080i Full	35	-512	511	-	
			R V Cent		Full / Normal	20	-512	511	-
					Zoom / V.Comp	20	-512	511	-
					WideZoom	20	-512	511	-
					1080i Full	20	-512	511	-
			G H Cent		Full / Normal	35	-512	511	-
					Zoom / V.Comp	35	-512	511	-
					WideZoom	35	-512	511	-
					1080i Full	35	-512	511	-
			G V Cent		Full / Normal	20	-512	511	-
					Zoom / V.Comp	20	-512	511	-
					WideZoom	20	-512	511	-
					1080i Full	20	-512	511	-

ADJUSTABLE SERVICE DATA LISTS

CATEGORY	#	ITEM	DESCRIPTION	CONDITION	46WT510	MIN	MAX	+ = Unsigned - = Signed
PJE			B H Cent	Full / Normal	35	-512	511	-
				Zoom / V.Comp	35	-512	511	-
				WideZoom	35	-512	511	-
				1080i Full	35	-512	511	-
			B V Cent	Full / Normal	20	-512	511	-
				Zoom / V.Comp	20	-512	511	-
				WideZoom	20	-512	511	-
				1080i Full	20	-512	511	-
	SKEW		R H Skew	Full / Normal	0	-512	511	-
				Zoom / V.Comp	0	-512	511	-
				WideZoom	0	-512	511	-
				1080i Full	0	-512	511	-
			R V Skew	Full / Normal	0	-512	511	-
				Zoom / V.Comp	0	-512	511	-
				WideZoom	0	-512	511	-
				1080i Full	0	-512	511	-
			G H Skew	Full / Normal	0	-512	511	-
				Zoom / V.Comp	0	-512	511	-
				WideZoom	0	-512	511	-
				1080i Full	0	-512	511	-

ADJUSTABLE SERVICE DATA LISTS

CATEGORY	#	ITEM	DESCRIPTION	CONDITION	46WT510	MIN	MAX	+ = Unsigned - = Signed
PJE			G V Skew	Full / Normal	0	-512	511	-
				Zoom / V.Comp	0	-512	511	-
				WideZoom	0	-512	511	-
				1080i Full	0	-512	511	-
			B H Skew	Full / Normal	0	-512	511	-
				Zoom / V.Comp	0	-512	511	-
				WideZoom	0	-512	511	-
				1080i Full	0	-512	511	-
			B V Skew	Full / Normal	0	-512	511	-
				Zoom / V.Comp	0	-512	511	-
				WideZoom	0	-512	511	-
				1080i Full	0	-512	511	-
		SIZE	R H Size	Full / Normal	-100	-512	511	-
				Zoom / V.Comp	-100	-512	511	-
				WideZoom	-100	-512	511	-
				1080i Full	-100	-512	511	-
			R V Size	Full / Normal	-75	-512	511	-
				Zoom / V.Comp	-75	-512	511	-
				WideZoom	-75	-512	511	-
				1080i Full	-75	-512	511	-

ADJUSTABLE SERVICE DATA LISTS

CATEGORY	#	ITEM	DESCRIPTION	CONDITION	46WT510	MIN	MAX	+ = Unsigned - = Signed
PJE			G H Size	Full / Normal	-100	-512	511	-
				Zoom / V.Comp	-100	-512	511	-
				WideZoom	-100	-512	511	-
				1080i Full	-100	-512	511	-
			G V Size	Full / Normal	-75	-512	511	-
				Zoom / V.Comp	-75	-512	511	-
				WideZoom	-75	-512	511	-
				1080i Full	-75	-512	511	-
			B H Size	Full / Normal	-100	-512	511	-
				Zoom / V.Comp	-100	-512	511	-
				WideZoom	-100	-512	511	-
				1080i Full	-100	-512	511	-
			B V Size	Full / Normal	-75	-512	511	-
				Zoom / V.Comp	-75	-512	511	-
				WideZoom	-75	-512	511	-
				1080i Full	-75	-512	511	-
		LIN	R H Lin	Full / Normal	425	-512	511	-
				Zoom / V.Comp	425	-512	511	-
				WideZoom	425	-512	511	-
				1080i Full	425	-512	511	-

ADJUSTABLE SERVICE DATA LISTS

CATEGORY	#	ITEM	DESCRIPTION	CONDITION	46WT510	MIN	MAX	+ = Unsigned - = Signed
PJE			R V Lin	Full / Normal	0	-512	511	-
				Zoom / V.Comp	0	-512	511	-
				WideZoom	0	-512	511	-
				1080i Full	0	-512	511	-
			G H Lin	Full / Normal	0	-512	511	-
				Zoom / V.Comp	0	-512	511	-
				WideZoom	0	-512	511	-
				1080i Full	0	-512	511	-
			G V Lin	Full / Normal	0	-512	511	-
				Zoom / V.Comp	0	-512	511	-
				WideZoom	0	-512	511	-
				1080i Full	0	-512	511	-
			B H Lin	Full / Normal	-425	-512	511	-
				Zoom / V.Comp	-425	-512	511	-
				WideZoom	-425	-512	511	-
				1080i Full	-425	-512	511	-
			B V Lin	Full / Normal	0	-512	511	-
				Zoom / V.Comp	0	-512	511	-
				WideZoom	0	-512	511	-
				1080i Full	0	-512	511	-

ADJUSTABLE SERVICE DATA LISTS

CATEGORY	#	ITEM	DESCRIPTION	CONDITION	46WT510	MIN	MAX	+ = Unsigned - = Signed	
PJE		KEY	R V Key	Full / Normal	120	-512	511	-	
			.	Zoom / V.Comp	120	-512	511	-	
			.	WideZoom	120	-512	511	-	
			.	1080i Full	120	-512	511	-	
			G V Key	Full / Normal	0	-512	511	-	
				.	Zoom / V.Comp	0	-512	511	-
				.	WideZoom	0	-512	511	-
				.	1080i Full	0	-512	511	-
			B V Key	Full / Normal	-120	-512	511	-	
				.	Zoom / V.Comp	-120	-512	511	-
				.	WideZoom	-120	-512	511	-
				.	1080i Full	-120	-512	511	-
		PIN	R H Pin	Full / Normal	0	-512	511	-	
				.	Zoom / V.Comp	0	-512	511	-
				.	WideZoom	0	-512	511	-
				.	1080i Full	0	-512	511	-
			R V Pin	Full / Normal	350	-512	511	-	
				.	Zoom / V.Comp	350	-512	511	-
				.	WideZoom	350	-512	511	-
				.	1080i Full	350	-512	511	-

ADJUSTABLE SERVICE DATA LISTS

CATEGORY	#	ITEM	DESCRIPTION	CONDITION	46WT510	MIN	MAX	+ = Unsigned - = Signed
PJE			G H Pin	Full / Normal	0	-512	511	-
				Zoom / V.Comp	0	-512	511	-
				WideZoom	0	-512	511	-
				1080i Full	0	-512	511	-
			G V Pin	Full / Normal	400	-512	511	-
				Zoom / V.Comp	400	-512	511	-
				WideZoom	400	-512	511	-
				1080i Full	400	-512	511	-
			B H Pin	Full / Normal	0	-512	511	-
				Zoom / V.Comp	0	-512	511	-
				WideZoom	0	-512	511	-
				1080i Full	0	-512	511	-
			B V Pin	Full / Normal	350	-512	511	-
				Zoom / V.Comp	350	-512	511	-
				WideZoom	350	-512	511	-
				1080i Full	350	-512	511	-
		MLIN	R H MLin	Full / Normal	0	-512	511	-
				Zoom / V.Comp	0	-512	511	-
				WideZoom	-150	-512	511	-
				1080i Full	0	-512	511	-

ADJUSTABLE SERVICE DATA LISTS

CATEGORY	#	ITEM	DESCRIPTION	CONDITION	46WT510	MIN	MAX	+ = Unsigned - = Signed
PJE			G H M Lin	Full / Normal	0	-512	511	-
				Zoom / V.Comp	0	-512	511	-
				WideZoom	0	-512	511	-
				1080i Full	0	-512	511	-
			B H M Lin	Full / Normal	0	-512	511	-
				Zoom / V.Comp	0	-512	511	-
				WideZoom	150	-512	511	-
				1080i Full	0	-512	511	-
		MSIZ	R H Middle Size	Full / Normal	0	-512	511	-
				Zoom / V.Comp	0	-512	511	-
				WideZoom	-100	-512	511	-
				1080i Full	0	-512	511	-
			G H Middle Size	Full / Normal	0	-512	511	-
				Zoom / V.Comp	0	-512	511	-
				WideZoom	-200	-512	511	-
				1080i Full	0	-512	511	-
			B H Middle Size	Full / Normal	0	-512	511	-
				Zoom / V.Comp	0	-512	511	-
				WideZoom	-100	-512	511	-
				1080i Full	0	-512	511	-

2-11-1.ID MAP TABLE

Reg.No & Name	FUNCTION		
0	ID0	Selection of OSD languages & color systems	89
1	ID1	Selection of composite & s-video inputs	127
2	ID2	Selection of audio-related controls	239
3	ID3	Selection of basic system settings	98
4	ID4	Selection of basic system settings	203
5	ID5	Selection of advanced system settings	177
6	ID6	Selection of sub picture related settings	54
7	ID7	Selection of some reserved settings	24

2-12-1.SET-UP FOR ADJUSTMENT

MARKING

- At the 4 sides of the screen, use a tape measure to locate the middle.

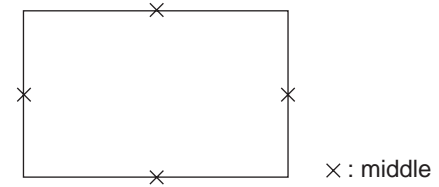

DATA SETTING

- Set NTSC Full mode.
- Enter the service mode, and select "PJE".

2-12-2.MAIN DEFLECTION ADJUSTMENT

NOTE: Before this adjustment, refer to section 2-11 for PJE input data items #78-85.

- Cover the red and blue CRT lenses with lens caps to allow only green to show (or use the method shown in the note below for turning off the CRTs individually without using lens caps).
- Enter the monoscope signal and set to NTSC Full mode.
- Enter the service mode, and select "2150D-1".
- Adjust "0 VPOS" and "1 VSIZ" so that the picture is displayed in the center of the screen.
- Adjust "2VSZ0" for 1080i vertical size adjustment.

0 VPOS

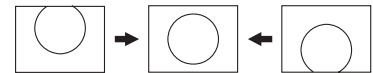

1 V-Size



- Select "2150D-2" and adjust "2 H-Size" so that the picture size is within the specification.

SPEC	Overscan Spec. = 9%	
	H SIZE	V SIZE
Input Signal		
Monoscope	15.6 ± 0.2 sq.	11.5 ± 0.2 sq.

2 H-Size

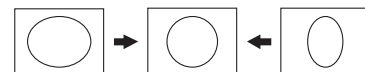

- Copy the data of the NTSC Full mode to the other display mode and, if necessary, adjust in the other mode.

2-12.REGISTRATION ADJUSTMENT

*ADJUSTING FLOW

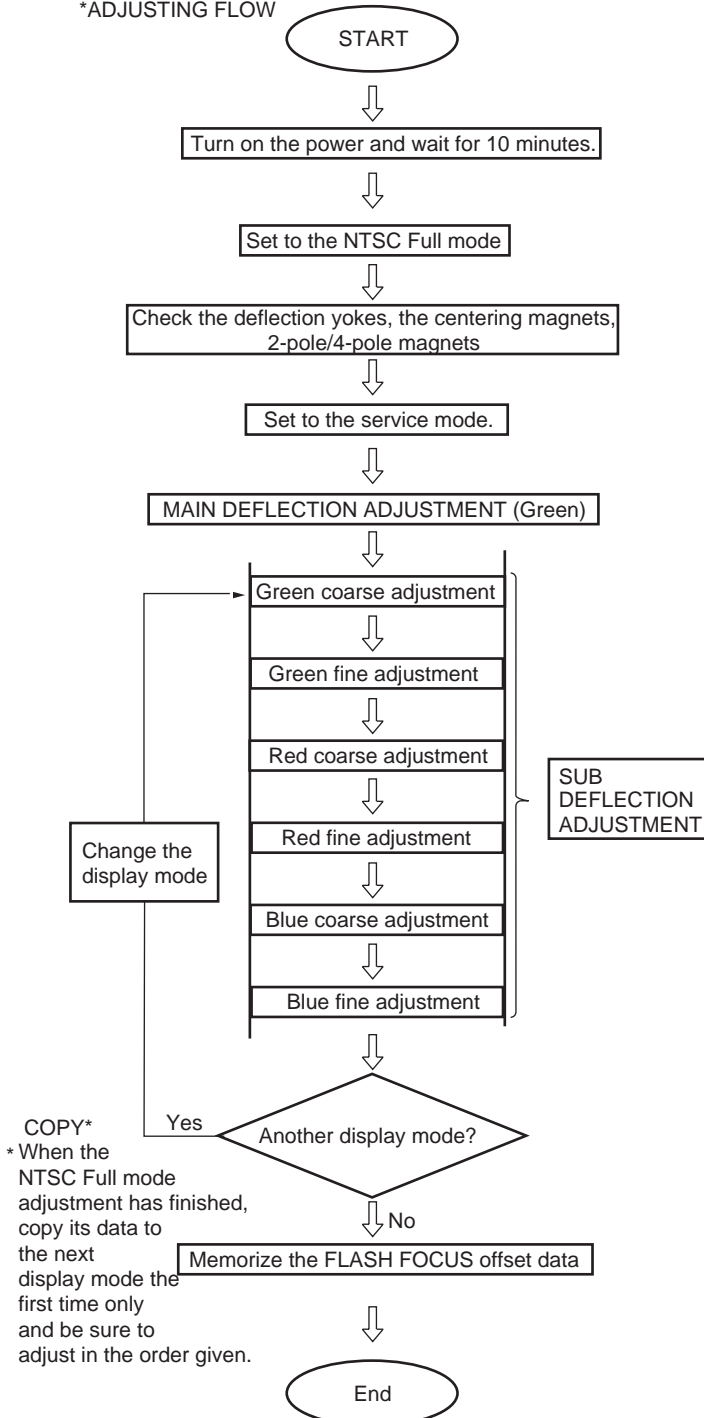

2-12-3. OPERATION METHOD FOR PROJECTOR ENGINE MODE

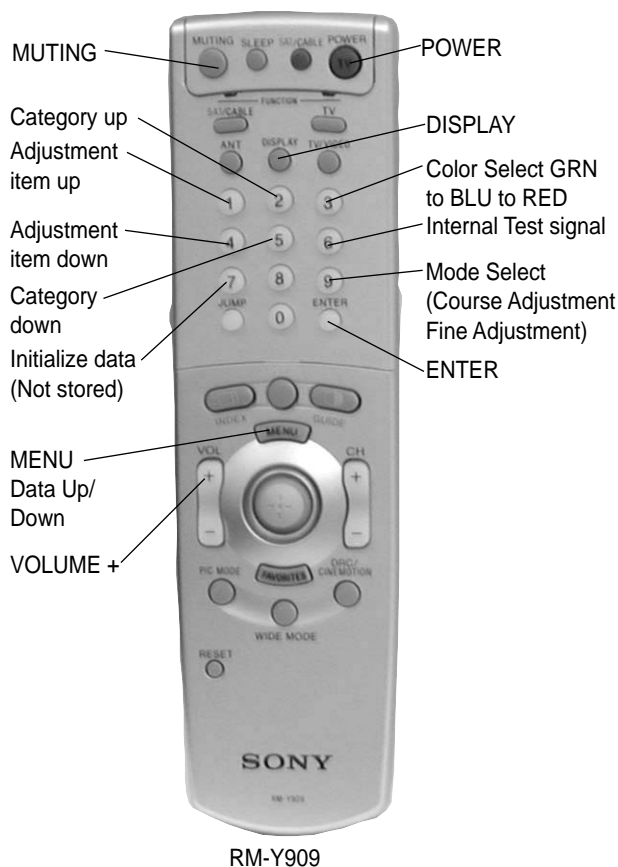

1. FUNCTION OF KEYS ON COMMANDER

- ① Changes adjustment item. (Item # moves up)
Marker moves clockwise from center to outside.
(In Fine Adjustment mode)
- ④ Changes adjustment item. (Item # moves down)
Marker moves counter clockwise from outside to center.
(In Fine Adjustment mode)
- ② Changes adjustment category.
(Category # moves up)
- ⑤ Changes adjustment category.
(Category # moves down)

Joystick Changes data value. (Up or down)

Marker moves clockwise from center (up, down, right, and then left) to outside.
(In Fine Adjustment mode)

- ③ Changes adjustment color.
GRN → BLU → RED
- ⑥ Displays or changes internal test signals.
crosshatch + external signal →
crosshatch + borderline →
crosshatch only →
dot only → off
- ⑨ Switches adjustment mode.
Coarse adjustment model →
Fine adjustment mode

Press Switches marker moving method.

Joystick (In Fine Adjustment mode)

Joystick ▲ ▼ ◀ ▶ keys → 1 and 4 buttons

Commander Function

Buttons	Mode	Description
0 + ENTER	READ	Reads data to NVM.
MUTING+ENTER	WRITE	Writes data from NVM.
7 + ENTER	PJE INITIAL	Service data initialization. Not stored. (Be sure not to use usually)

2. OPERATION METHOD FOR COARSE ADJUSTMENT

1. Enter the service mode and select "PJE".
2. Press the "1" or "4" button on the remote commander to select the item, and then use the joystick to change the data.

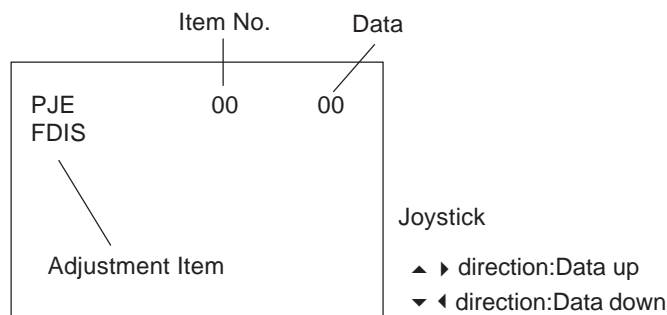

3. Select "GRN CENT". When BLU or RED is displayed, press the "3" button on the remote commander to change the adjustment color in the order of GRN → BLU → RED.
4. In GRN, BLU, or RED mode, move the joystick ▲ or ▼ to change the data in vertical direction, or ◀ or ▶ to change the data in a horizontal direction.

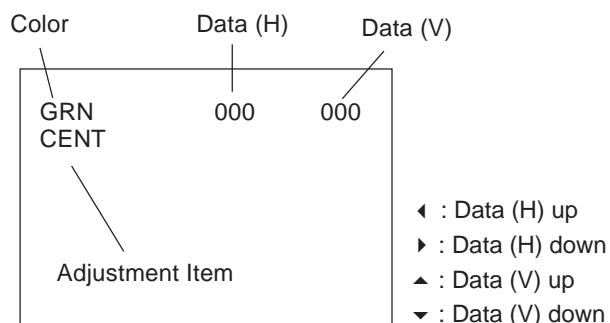

5. Before returning to the service mode, press the "MUTING" + "ENTER" buttons on the remote commander to write the data. (You must complete step 5 to write the data. If you omit step 5 the set data is returned to the data prior to the adjustment.)

3. OPERATION METHOD FOR FINE ADJUSTMENT

1. Enter the service mode and select "PJE".
2. Select FDIS and set the data to "01" so that the data at each position can be displayed in fine adjustment mode.

3. Press the "9" button on the remote commander and fine adjustment mode will be active where a green marker appears in the center of the screen. (In the case of GRN mode)
4. Press down on the joystick, and the marker color will be alternately switched between green (GRN mode) and white.
5. Press the "1" or "4" button on the remote commander, or use the joystick to move the marker to the position to be adjusted, where fine adjustment can be made.

* When the marker color is white:
(in this case, fine adjustment is disabled)

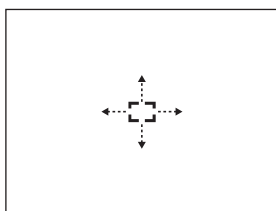

Use the joystick to move the marker up, down, left, or right.

* When the marker color is green:
(GRN mode)

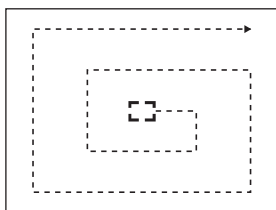

- ① : Moves the marker clockwise from the center to the outside.
- ④ : Moves the marker counter clockwise from the outside to the center.

* Fine adjustment can be made on the basis of a marker position using the joystick to move ▲ ▼ ◀ ▶.

Move joystick ▲ direction

Move joystick ▶ direction

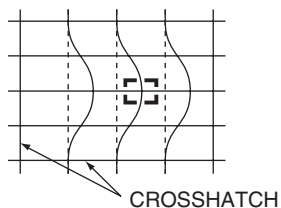
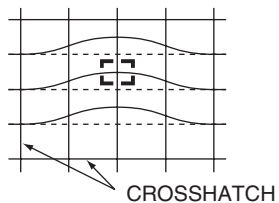

6. Press the "9" button on the remote commander to return to coarse adjustment mode.

2-13.PJE ADJUSTMENT (SUB DEFLECTION ADJUSTMENT)

Adjustment item	Adjustment type		
	G	R	B
	H/V*	H/V*	H/V*
CENT	O/O	O/O	O/O
SKEW	O/O	O/O	O/O
SIZE	O/O	O/O	O/O
LIN	O/O	O/O	O/O
KEY	-/O	-/O	-/O
PIN	O/O	O/O	O/O
MLIN	O/-	O/-	O/-
MSIZ	O/-	O/-	O/-

* H = Horizontal V = Vertical O = Yes -- = No

Note: If the value is over the limit value, adjust these in the fine adjustment mode.

Coarse Data Limit Value:

CENT H	35 ± 170V
CENT V	20 ± 170V
SIZE H	-75 MAX
BLUE H LIN	-425 MIN
RED H LIN	425 MAX

2-13-1.ADJUSTMENT FOR NTSC FULL MODE

- The adjustment should be done in the numerical order given.

1) GREEN ADJUSTMENT

1. Cover the red and blue CRT lenses with lens caps to allow only green to show (or use the method shown in the note below for turning off the CRTs individually without using lens caps).

Note: If lens caps are unavailable, you can cut off the unnecessary color beams by controlling the service mode 2150P-2 1 RGBS.

2. Enter the monoscope signal to set.
3. Select the PJE mode.
4. Press the "6" button on the remote commander to display the internal test signal (crosshatch).
5. Select "GRN CENT", and adjust so that the pictures coincide in the center of screen.

GRN CENT (Horizontally/Vertically)

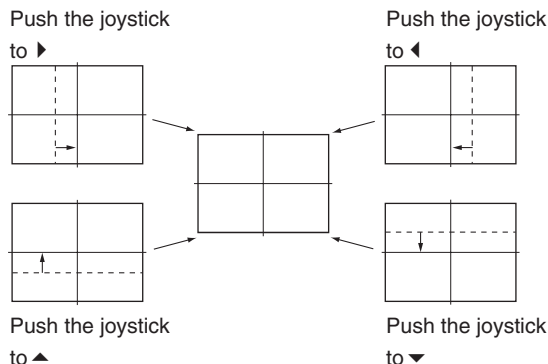

7. Select "GRN SKEW", and correct the tilt of horizontal lines and vertical lines.

GRN SKEW (Horizontally/Vertically)

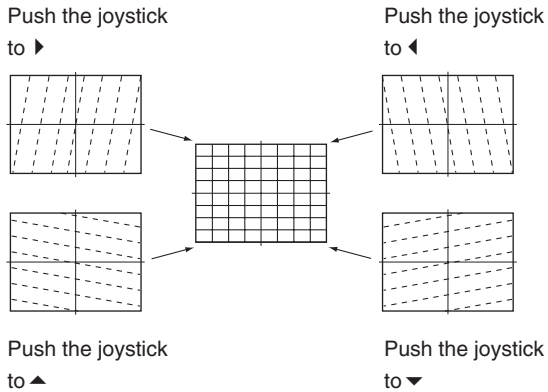

8. Select "GRN SIZE", and adjust so that each distance from center to left end and to right end is equal. Adjust so that each distance from center to top and to bottom is equal.

GRN SIZE (Horizontally/Vertically)

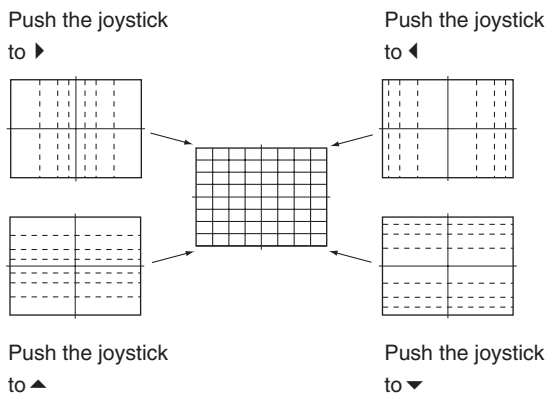

9. Select "GRN LIN", and adjust so that each space at the right end and at the left end of screen is equal. Adjust so that each space at the top and at the bottom of screen is equal.

GRN LIN (Horizontally/Vertically)

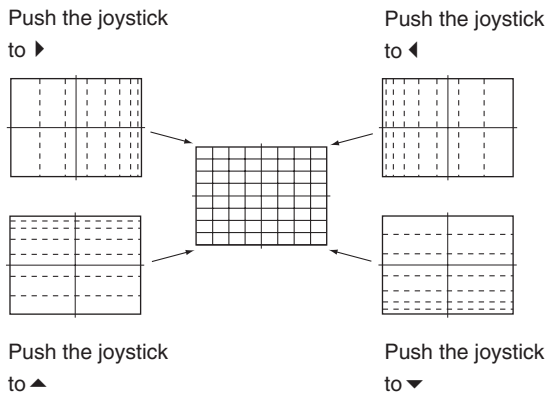

10. Select "GRN MSIZ", and correct the space intervals for the horizontal section so the screen is equal.

GRN MSIZ (Horizontally)

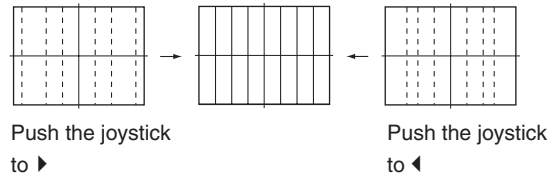

11. Select "GRN MLIN", and correct the sizes of the horizontal line so the center of the screen is symmetrical left and right.

GRN MLIN (Horizontally)

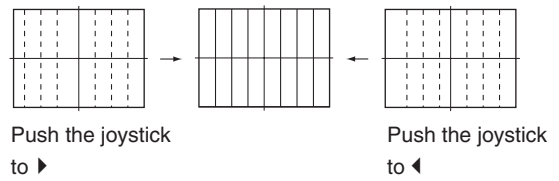

Note: The SIZE and LIN, MSIZ and MLIN adjustments affect each other. If necessary, adjust these mutually.

12. Select "GRN PIN", and adjust so that right and left vertical lines on the screen become straight. Adjust so that upper and lower horizontal lines on the screen become straight.

GRN PIN (Horizontally/Vertically)

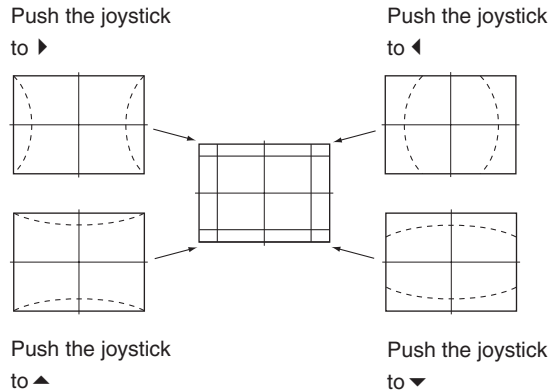

13. Select "GRN KEY", and adjust so that upper and lower horizontal lines on the screen become parallel.

GRN KEY (Vertically)

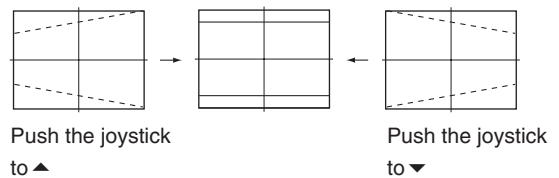

Note: The VPIN and KEY adjustments affect each other. If necessary, adjust these mutually.

14. Press the "9" button on the remote commander to enter fine adjustment mode.

15. Make the fine adjustment so that horizontal lines and vertical lines become straight.
16. Press the "9" button on the remote commander to return to coarse adjustment mode.

2) RED ADJUSTMENT

1. Cover the blue CRT lens with a lens caps to allow only the green and red to show (or use the method shown in the note below for turning off the CRTs individually without using lens caps).
2. Press the "3" button on the remote commander to select RED mode.
3. Adjust the following items so that red lines overlap with green lines.
 - RED CENT (horizontally/vertically)
 - RED SKEW (horizontally/vertically)
 - RED SIZE (horizontally/vertically)
 - RED LIN (horizontally/vertically)
 - RED MSIZ (horizontally)
 - RED MLIN (horizontally)
 - RED PIN (horizontally/vertically)
 - RED KEY (vertically)
4. Press the "9" button on the remote commander to enter fine adjustment mode.
5. Make the fine adjustment so that horizontal lines and vertical lines overlap with green lines.
6. Press the "9" button on the remote commander to return to coarse adjustment mode.

Note: If lens caps are unavailable, you can cut off the unnecessary color beams by controlling the service mode 2150P-2 1 RGBS.

3) BLUE ADJUSTMENT

1. Remove the lens cap from the blue picture lens to display all colors.
2. Press the "3" button on the remote commander to select BLU mode.
3. Adjust the following items so that blue lines overlap with green and red lines.
 - BLU CENT (horizontally/vertically)
 - BLU SKEW (horizontally/vertically)
 - BLU SIZE (horizontally/vertically)
 - BLU LIN (horizontally/vertically)
 - BLU MSIZ (horizontally)
 - BLU MLIN (horizontally)
 - BLU PIN (horizontally/vertically)
 - BLU KEY (vertically)
4. Press the "9" button on the remote commander to enter fine adjustment mode.
5. Make the fine adjustment so that horizontal lines and vertical lines overlap with green and red lines.
6. Press the "9" button on the remote commander to return to coarse adjustment mode.

4) REGISTRATION DATA WRITING

1. After completing each adjustment of green, blue, and red for the NTSC Full mode press the "MUTING"+ "ENTER" buttons on the remote commander to write the registration data to the NVM.

2-13-2.COPYING ALL REGISTRATION DATA TO OTHER MODES

1. Make sure that the adjustment for NTSC Full mode are complete and the data have already been written.
2. Select the PJE mode.
3. Select Copy and set the data to "01", and press the "MUTING"+"ENTER" buttons on the remote commander.
4. The data from the NTSC Full mode is copied to all other modes.

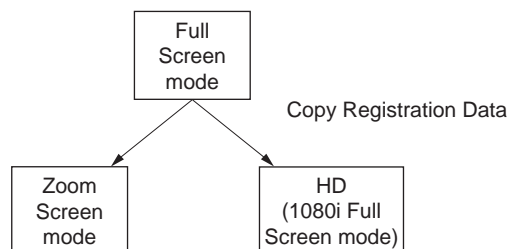

5. Check in the other modes and adjust as demands.
Be sure to write data in each mode.

2-14.AUTO REGISTRATION OFFSETS

IMPORTANT

This adjustment must be performed after registration adjustment or after readjustment for any reason!

Once registration in all modes is satisfactory:

1. Darken the room environment near the set.
 2. Select input of RF (with a signal) or Video1 - Video4 (with a signal), and enter Full Mode.
- WARNING: DO NOT USE 1080i SIGNAL!**
3. Enter service mode and select the PJE group.
 4. Press the "MUTING" + "ENTER" buttons on the remote commander to write the data for Full mode.

Important:

You must complete step 4 even if registration looks OK in Full mode and there were not any adjustments made.

5. To automatically store the offset values, press the "FLASH FOCUS" button on the front panel of the set.
(The offset value is now stored)
If FLASH FOCUS successfully calibrates, it displays "CALIBRATION OK."
If FLASH FOCUS does not successfully calibrate, an error message is displayed. (Refer to section 2-15)
6. Exit the service mode.
7. If the calibration was successful, press the "FLASH FOCUS" button out of service mode.
8. Confirm registration is OK in all modes.

2-15.AUTO REGISTRATION ERROR CODES

If an error code is displayed after the set has been correctly adjusted, check the following items: position, tilt and sizing. If any of these adjustments are off, even slightly, the auto-registration pattern will not hit the four sensors properly. This occurs when the internal generator patterns are being flashed on the screen for the sensors to read. Therefore, auto registration (called auto convergence) cannot operate properly, causing an error code to be displayed. In order for this function to operate properly correct position, tilt, and size must be adjusted properly.

ERROR CODE LIST

ERROR CODE	DESCRIPTION	NOTE
00	No Error	
10	Sensor 0 low output	Check sensor 0, connection/wiring, circuit, and pattern position (are patterns hitting sensor?) adjust 66 VUP, 70 HMID if necessary.
11	Sensor 1 low output	Check sensor 1, connection/wiring, circuit, and pattern position (are patterns hitting sensor?) adjust 69 HLE, 67 VMID if necessary.
12	Sensor 2 low output	Check sensor 2, connection/wiring, circuit, and pattern position (are patterns hitting sensor?) adjust 71 HRIV, 67 VMID if necessary.
13	Sensor 3 low output	Check sensor 3, connection/wiring, circuit, and pattern position (are patterns hitting sensor?) adjust 68 VLOW, 70 HMID if necessary.
20	Sensor 0 high output	Check sensor 0 and circuit.
21	Sensor 1 high output	Check sensor 1 and circuit.
22	Sensor 2 high output	Check sensor 2 and circuit.
23	Sensor 3 high output	Check sensor 3 and circuit.
30	V CENT or SKEW adjustment loop overflow	Check 67 VMID data and check registration condition.
31	H CENT or SKEW adjustment loop overflow	Check 70 HMID data and check registration condition.
32	H LIN or SIZE adjustment loop overflow	Check 69 HLE and 71 HRIV data and check registration condition.
40	V CENT regi data overflow	Check 67 VMID data and confirm V CENT data (all modes) is not near 511.
41	H CENT regi data overflow	Check 70 HMID data and confirm H CENT data (all modes) is not near 511.
42	V SKEW regi data overflow	Check 67 VMID data and confirm V SKEW data (all modes) is not near 511.
43	H SKEW regi data overflow	Check 70 HMID data and confirm H SKEW data (all modes) is not near 511.
44	H LIN regi data overflow	Check 69 HLE and 71 HRIV data and confirm H CENT data (all modes) is not near 511.
45	H SIZE regi data overflow	Check 69 HLE and 71 HRIV data and confirm H CENT data (all modes) is not near 511.
50	V CENT regi data overdraw	Check 67 VMID data and confirm V CENT data (all modes) is not near -512.
51	H CENT regi data overdraw	Check 70 HMID data and confirm H CENT data (all modes) is not near -512.
52	V SKEW regi data overdraw	Check 67 VMID data and confirm V SKEW data (all modes) is not near -512.
53	H SKEW regi data overdraw	Check 70 HMID data and confirm H SKEW data (all modes) is not near -512.
54	H LIN regi data overdraw	Check 69 HLE and 71 HRIV data and confirm H LIN data (all modes) is not near -512.
55	H SIZE regi data overdraw	Check 69 HLE and 71 HRIV data and confirm H SIZE data (all modes) is not near -512.
60	CENT/SKEW calibration loop overflow	Check 70 HMID and 67 VMID data and check registration condition.
61	SIZE/LIN calibration loop overflow	Check 69 HLE, 71 HRIV, 66 VUP, and 68 VLOW data and check registration condition.
70	V CENT/SKEW ratio limit	Check sensors 1 and 2, connection/wiring, circuit, increase 65 RTLM.
71	H CENT/SKEW ratio limit	Check sensors 0 and 3, connection/wiring, circuit, increase 65 RTLM.
73	H SIZE/Lin ratio limit	Check sensors 1 and 2, connection/wiring, circuit, increase 65 RTLM.
80	SIZE Limit Error	Check that horizontal SIZE data is not near 64 SZLM.

SENSOR POSITIONS

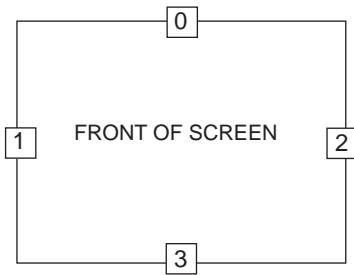

- 0: UPPER SENSOR
- 1: LEFT SENSOR
- 2: RIGHT SENSOR
- 3: LOWER SENSOR

• ERROR CODE SCREEN DISPLAY

Error codes in normal (customer) mode are not displayed. You must enter PJE service mode to see the error code.

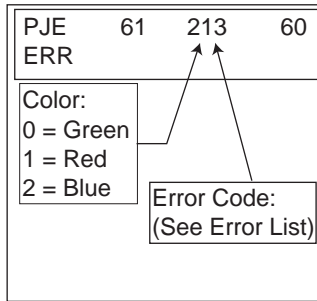

(Blue Sensor 3 Low Output)

In service mode, the error will be displayed in text format.

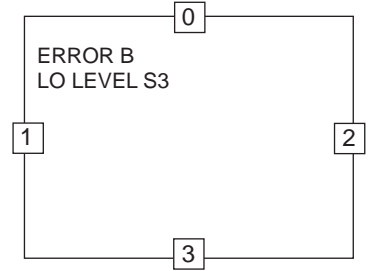

2-16.AUTO REGISTRATION DIAGNOSTICS

The TEST service item (PJE #72) can be used to determine if a sensor or sensor amplifier is working properly. It can also be used to check pattern positions.

133

- Color:** 0=Green, 1=Red, 2=Blue, 3=All
- CS/ZL:** 0=None, 1=Cent/Skew, 2=siZe/Lin, 3=Both
- Display/Loop:** 0=Display, 1:Loop

DISPLAY/ LOOP	CS/ZL	COLOR	ACTION
(0)	0	0	Normal calibration (no diagnostics).
(0)	X	X	Performs one adjustment cycle, then displays average peak voltages for the specified CS/ZL and Color.
(0)	3	3	Does nothing (can't display more than one CS/ZL or Color at a time.)
1	X	X	Adjusts specified CS/ZL and Color until a key is pressed. Useful for measuring signals with oscilloscope.

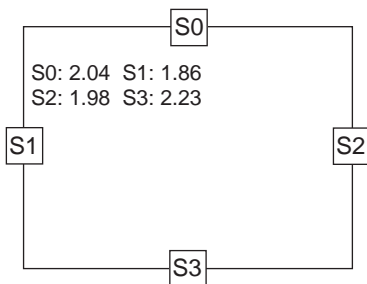



Sensor 0 peak voltage = 2.04 V, etc.

SECTION 3: SAFETY-RELATED ADJUSTMENTS

D BOARD

3-1. HV REGULATION CIRCUIT CHECK AND ADJUSTMENT

When replacing the following components marked with a  on the schematic diagram always check the HV regulation, and if necessary re-adjust.

Part Replaced ()	Adjustment ()
A BOARD: C8079, C8083, C8090, C8129, D8013, D8038, D8043, D8051, IC8006, Q8021, R8055, R8099, R8102, R8128, R8129, R8131, R8139, R8140, R8142, R8153, R8163, R8223, R8230, T8004 (LOT), T8005 (FBT), HV Block, D Board	HV REGULATOR VR8001

OPERATION CHECK

1. Receive the all white signal.
2. Set PIC MAX/BRT CENT.
3. Confirm that the voltage between CN8015  PIN and GND is less than 7.80VDC.

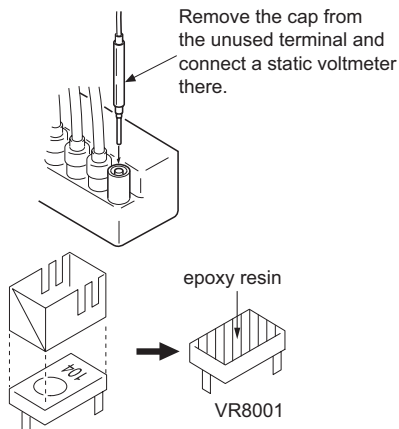

HV REGULATION ADJUSTMENT

1. Connect a HV static voltmeter to the unconnected plug of the high-voltage block.
2. Power on the set.
3. Receive the all white signal.
4. Set PIC MAX/BRT CENT.
5. Confirm that the static voltmeter reading is $31.0 \pm 0.4V$.
If not, adjust with VR8001 to the specified value.
6. After adjustment, put the VR cover on VR8001 (as shown below) and apply sufficient amount of epoxy resin around VR8001.



3-2. HV HOLD DOWN CIRCUIT OPERATION CHECK AND ADJUSTMENT

When replacing the following components marked with a  on the schematic diagram always check the hold-down voltage and re-adjust when necessary.

Part Replaced ()	Adjustment ()
A BOARD: C8054, C8086, C8088, C8100, C8104, C8118, C8123, C8124, C8094 D8019, D8020, D8022, D8028, D8036, FB8001, IC8008, Q8035, Q8043, R8035, R8043, R8159, R8166, R8171, R8196, R8201, T8004 (LOT), T8005 (FBT), HV Block, D Board	HV HOLD DOWN VR8002

OPERATION CHECK

1. Receive the dot signal.
2. Set PIC MIN/BRT MIN.
3. Confirm that the voltage between cathode of D8038 (JW171) and GND is more than 23.0V DC.
4. Using an external DC Power supply, apply the voltage shown below between cathode of D8038 (JW171) on "D" and GND, then confirm that the HV-Prot circuit works. (Raster disappears)
Apply DC voltage: Less than 29.05V DC.

HV HOLD-DOWN ADJUSTMENT

1. Connect a HV static voltmeter to the unconnected plug of the high-voltage block.
2. Power on the set.
3. Connect an external 10kΩ VR at CN8015 and adjust this VR so that the high voltage is 34.50kV.
4. Adjust VR8002 to the point that the HV-Prot circuit works (Raster disappears) at $34.50 \pm 0.50kV$ reading on the static voltmeter.
5. After adjustment, put the VR cover on VR8002 and apply sufficient amount of epoxy resin around VR8002 as the same manner for VR8001.

G BOARD

3-3. +B MAX VOLTAGE CONFIRMATION

The following adjustments should always be performed when replacing IC501, R5032.

1. Supply 130VAC to variable autotransformer.
2. Receive dot signal pattern and set the PICTURE and BRIGHTNESS settings to their minimum.
3. Confirm the voltage of TP +B 135V is less than 137.0Vdc.
4. If step 3 is not satisfied, replace IC501 and repeat steps 1-3.

3-4. +B OVP CONFIRMATION

1. Add to low voltage power supply between to TP5001 and ground.
2. Supply 120VAC to variable autotransformer.
3. Power on the Set and receive dot signal pattern.
4. Set the PICTURE and BRIGHTNESS settings.
5. Check the OVP is activated.
Operate :less than 2.50V

SECTION 4: CIRCUIT ADJUSTMENTS

4-1. BLUE OFFSET ADJUSTMENT

1. Receive the all black (1080i, component) signal with VIDEO 5 input, and set PICTURE to maximum.
2. Connect an oscilloscope between CN5 ⑦ pin (B) on the (A board) and ground.
3. Set in the service mode and select the category "2150D-2".
4. Adjust "SLIN" so that the waveform level is $2.20 \pm 0.05V_{pp}$.
5. After completing the adjustments, write the data into memory by pressing "MUTING" → "ENTER" on the remote commander.
6. Receive the RF signal and change the wide screen mode to "Wide Zoom". Copy the same data to "SLIN".

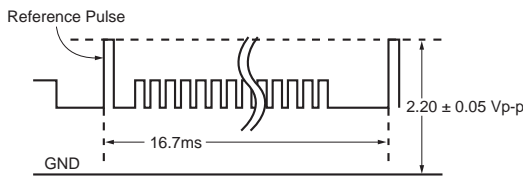

4-2. P & P SUB CONTRAST ADJUSTMENT (VIDEO) (SCON)

1. Receive the signal.

TV terminal (sub)	: Color-bar (white-75%, 7.5% setup)
VIDEO terminal (main)	: Color-bar (white-75%, 7.5% setup)
2. VIDEO MODE : Pro
 PICTURE : Maximum
 COLOR : Minimum
 2150P-2 1 RGBS : 2
3. Set to P & P mode, and set to service mode.
4. Connect an oscilloscope between the check point and ground.

Check points	: CN5 pin ⑥
A Board	: CN5 pin ⑥
5. Select "2103-1-02" (Main scon), and adjust so that the waveform level of V_{WB} is $1.55 \pm 0.04V_{p-p}$.
6. Select "2103-2-02" (Sub scon), and adjust so that the waveform level of V_{WB} is $1.55 \pm 0.04V_{p-p}$.
7. After completing the adjustments, write the data into memory by pressing "MUTING" → "ENTER" on the remote commander.

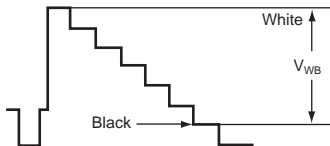

4-3. P & P SUB CONTRAST ADJUSTMENT (RF) (SCON)

1. Receive the signal.

TV terminal (sub)	: Color-bar (white-75%, 7.5% setup)
VIDEO terminal (main)	: Color-bar (white-75%, 7.5% setup)
2. VIDEO MODE : Pro
 PICTURE : Maximum
 COLOR : Minimum
 2150P-2 1 RGBS : 2
3. Set to P & P mode, and set to service mode.
4. Connect an oscilloscope between the check point and ground.

Check points	: CN5 ⑥
A Board	: CN5 ⑥
5. Select "2103-1-02" (Main scon), and adjust so that the waveform level of V_{WB} is $1.55 \pm 0.04V_{p-p}$.
6. Select "2103-2-02" (Sub scon), and adjust so that the waveform level of V_{WB} is $1.55 \pm 0.04V_{p-p}$.
7. After completing the adjustments, write the data into memory by pressing "MUTING" → "ENTER" on the remote commander.

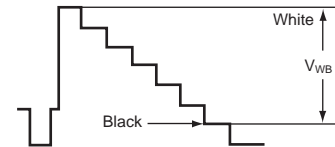

4-4. P & P SUB-HUE AND SUB-COLOR ADJUSTMENT (VIDEO) (SHUE, SCOL)

1. Receive the signal.

TV terminal (sub)	: Color-bar (white-75%, 7.5% setup)
VIDEO terminal (main)	: Color-bar (white-75%, 7.5% setup)
2. VIDEO MODE : Pro
 PICTURE : Maximum
 COLOR : Center
 2150P-2 1 RGBS : 7
3. Set to P & P mode, and set to service mode.
4. Connect an oscilloscope between pin ⑦ of CN5 (A board) connector and ground.
5. Select "2103-1-03 SCOL, -04 SHUE" (Main), and adjust them to have $VB1 \leq VB4$ and $VB2 \leq VB3$ in the waveform levels.
6. Select "2103-2-03 SCOL, -04 SHUE" (Sub), and adjust them to have $VB1 \leq VB4$ and $VB2 \leq VB3$ in the waveform levels.
7. After completing the adjustments, write the data into memory by pressing "MUTING" → "ENTER" on the remote commander.

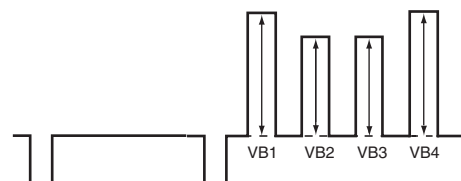

4-5. P & P SUB-HUE AND SUB-COLOR ADJUSTMENT (RF) (SHUE, SCOL)

1. Receive the signal.
 TV terminal (main) : Color-bar (white-75%, 7.5% setup)
 VIDEO terminal (sub) : Color-bar (white-75%, 7.5% setup)
2. VIDEO MODE : Pro
 PICTURE : Maximum
 COLOR : Center
 2150P-2 1 RGBS : 7
3. Set to P & P mode, and set to service mode.
4. Connect an oscilloscope between pin ⑦ of CN5 (A board) connector and ground.
5. Select "2103-1-03 SCOL, -04 SHUE" (Main), and adjust them to have $VB1 \leq VB4$ and $VB2 \leq VB3$ in the waveform levels.
6. Select "2103-2-03 SCOL, -04 SHUE" (Sub), and adjust them to have $VB1 \leq VB4$ and $VB2 \leq VB3$ in the waveform levels.
7. After completing the adjustments, write the data into memory by pressing "MUTING" → "ENTER" on the remote commander.

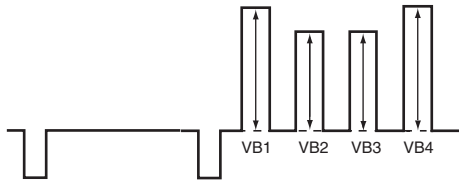

SECTION 5: DIAGRAMS

5-1. CIRCUIT BOARDS LOCATION

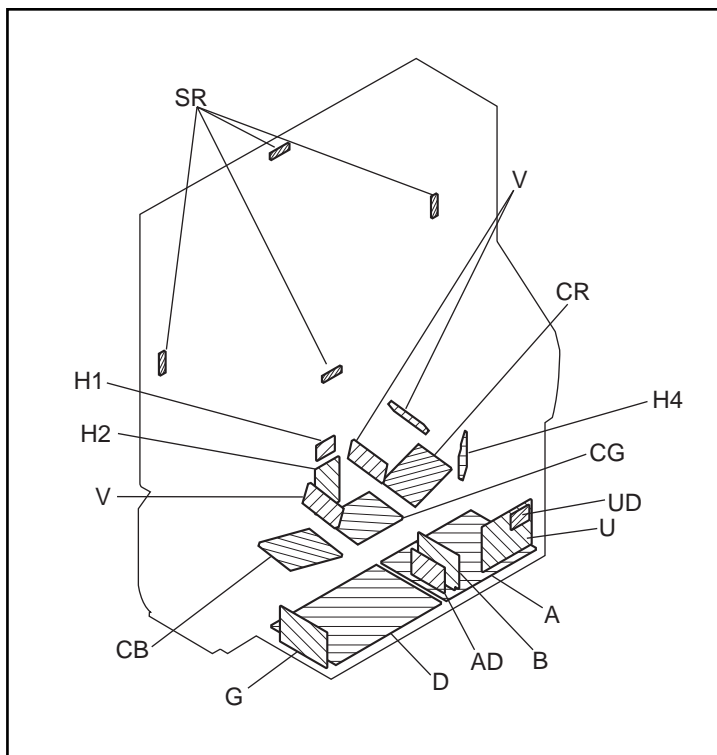

- : B+ line
- : B-line. (Actual measured value may be different).
- ⇒: signal path. (RF)

Circled numbers are waveform references.

The components identified by in this basic schematic diagram have been carefully factory-selected for each set in order to satisfy regulations regarding X-ray radiation. Should replacement be necessary, replace only with the value originally used.

When replacing components identified by , make the necessary adjustments as indicated. If the results do not meet the specified value, change the component identified by and repeat the adjustment until the specified value is achieved.

(Refer to adjustments in Sections 3-1 and 3-2.)

When replacing the parts listed in the table below, it is important to perform the related adjustments.

Part Replaced ()	Adjustment ()
<p>A BOARD: C8079, C8083, C8090, C8129, D8013, D8038, D8043, D8051, IC8006, Q8021, R8055, R8099, R8102, R8128, R8129, R8131, R8139, R8140, R8142, R8153, R8163, R8223, R8230, T8004 (LOT), T8005 (FBT), HV Block, D Board</p>	<p>HV REGULATOR VR8001</p>
<p>A BOARD: C8054, C8086, C8088, C8100, C8104, C8118, C8123, C8124, C8094 D8019, D8020, D8022, D8028, D8036, FB8001, IC8008, Q8035, Q8043, R8035, R8043, R8159, R8166, R8171, R8196, R8201, T8004 (LOT), T8005 (FBT), HV Block, D Board</p>	<p>HV HOLD DOWN VR8002</p>

5-2. PRINTED WIRING BOARDS AND SCHEMATIC DIAGRAMS INFORMATION

All capacitors are in μF unless otherwise noted. pF : μF 50WV or less are not indicated except for electrolytics and tantalums.

All electrolytics are in 50V unless otherwise specified.

All resistors are in ohms. K=1000, M=1000k

Indication of resistance, which does not have one for rating electrical power, is as follows: Pitch : 5mm

Rating electrical power : $\frac{1}{4}$ W

$\frac{1}{4}$ W in resistance, $\frac{1}{10}$ W and $\frac{1}{8}$ W in chip resistance.

: nonflammable resistor.

: fusible resistor.

: internal component.

: panel designation and adjustment for repair.

\perp : earth ground

/// : earth-chassis

All variable and adjustable resistors have characteristic curve B, unless otherwise noted.

Readings are taken with a NTSC color-bar signal input.

Readings are taken with a 10M digital multimeter.

Voltages are DC with respect to ground unless otherwise noted.

Voltage variations may be noted due to normal production tolerances.

All voltages are in V.

S : Measurement impossibility.

REFERENCE INFORMATION

RESISTOR : RN METAL FILM
 : RC SOLID
 : FPRD NONFLAMMABLE CARBON
 : FUSE NONFLAMMABLE FUSIBLE
 : RW NONFLAMMABLE WIREWOUND
 : RS NONFLAMMABLE METAL OXIDE
 : RB NONFLAMMABLE CEMENT
 : ✕ ADJUSTMENT RESISTOR

COIL : LF-8L MICRO INDUCTOR

CAPACITOR : TA TANTALUM
 : PS STYROL
 : PP POLYPROPYLENE
 : PT MYLAR
 : MPS METALIZED POLYESTER
 : MPP METALIZED POLYPROPYLENE
 : ALB BIPOLAR
 : ALT HIGH TEMPERATURE
 : ALR HIGH RIPPLE













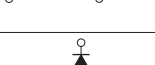





















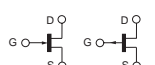

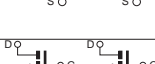

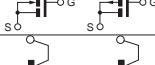

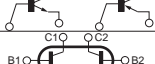

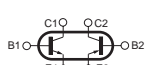

NOTE: The components identified by shading and  mark are critical for safety. Replace only with part number specified.

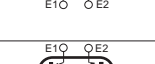
The symbol  indicates a fast operating fuse and is displayed on the component side of the board. Replace only with fuse of the same rating as marked.

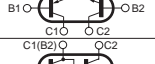
NOTE: Les composants identifiés par un trame et une marque  sont critiques pour la sécurité. Ne les remplacer que par une pièce portant le numéro spécifié.

Le symbole  indique une fusible à action rapide. Doit être remplacé par une fusible de même valeur, comme marqué.

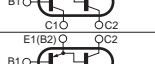
Terminal name of semiconductors in silk screen printed circuit (*)

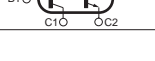
	Device	Printed symbol	Terminal name	Circuit
①	Transistor		Collector Base Emitter	
②	Transistor		Collector Base Emitter	
③	Diode		Cathode Anode	
④	Diode		Cathode Anode (NC)	
⑤	Diode		Cathode Anode (NC)	
⑥	Diode		Common Anode Cathode	
⑦	Diode		Common Anode Cathode	
⑧	Diode		Common Anode Anode	
⑨	Diode		Common Anode Anode	
⑩	Diode		Common Cathode Cathode	
⑪	Diode		Common Cathode Cathode	
⑫	Diode		Anode Anode Cathode Anode	
⑬	Transistor (FET)		Drain Source Gate	
⑭	Transistor (FET)		Drain Source Gate	
⑮	Transistor (FET)		Source Drain Gate	
⑯	Transistor		Emitter Collector Base	
⑰	Transistor		C2 B1 E1 E2 B2 C1	
⑱	Transistor		C1 B2 E2 E1 B1 C2	
⑲	Transistor		C1 B2 E2 E1 B1 C2	
⑳	Transistor		C1 B2 E2 E1 B1 C2	
㉑	Transistor		E2 B1 E1 C2 C1(B2)	
㉒	Transistor		(B2) B1 E1 E2 C1 C2	
㉓	Transistor		(B2) E2 E1 B1 C2 C1	
-	Discrete semiconductor			

(Chip semiconductors that are not actually used are included.)

Ver.1.6

5-3. BLOCK DIAGRAMS

BLOCK DIAGRAM (1 OF 3)

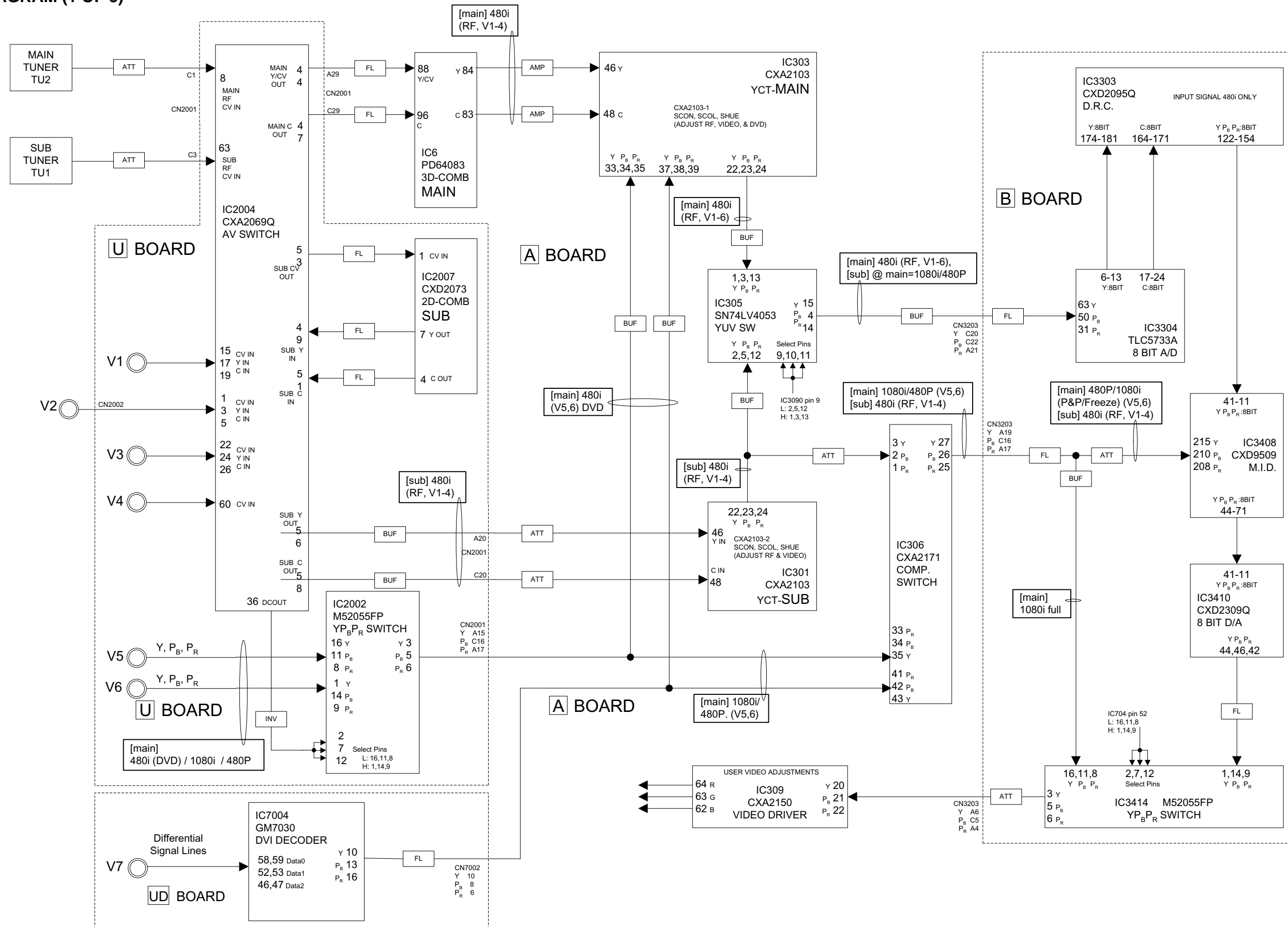

BLOCK DIAGRAM (2 OF 3)

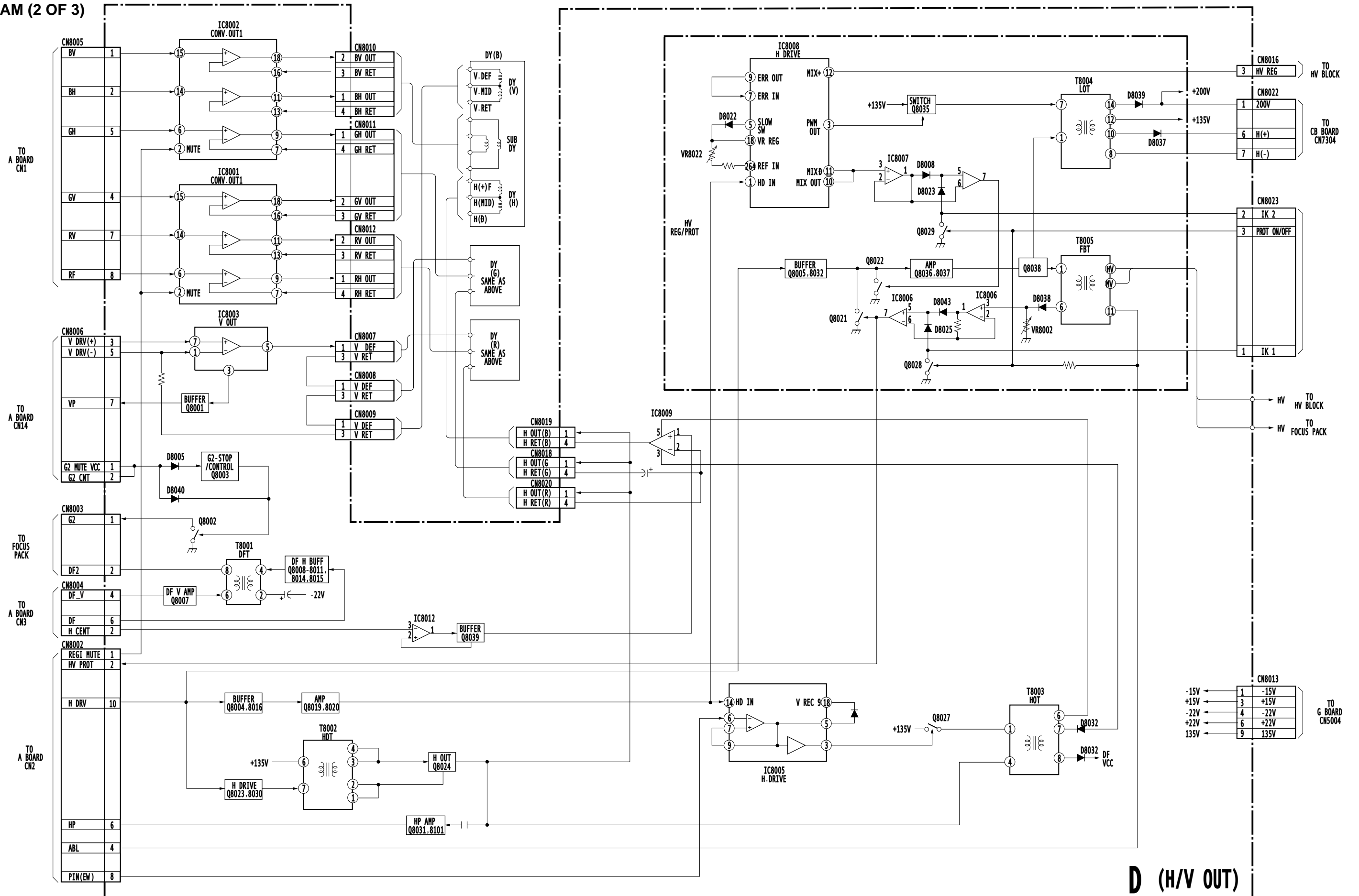

D (H/V OUT)

BLOCK DIAGRAM (3 OF 3)

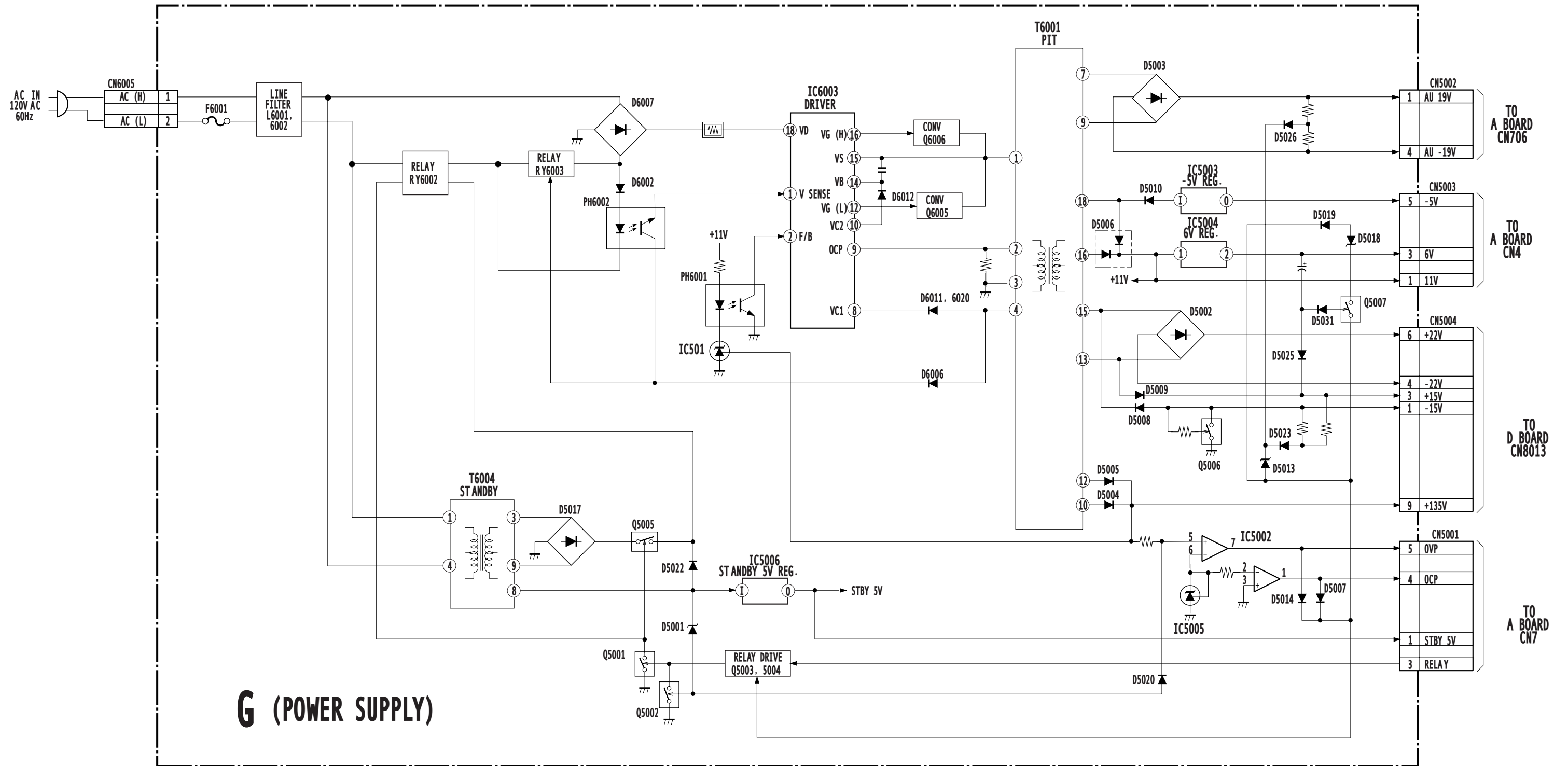

5-4. SCHEMATICS AND SUPPORTING INFORMATION

CR BOARD SCHEMATIC DIAGRAM

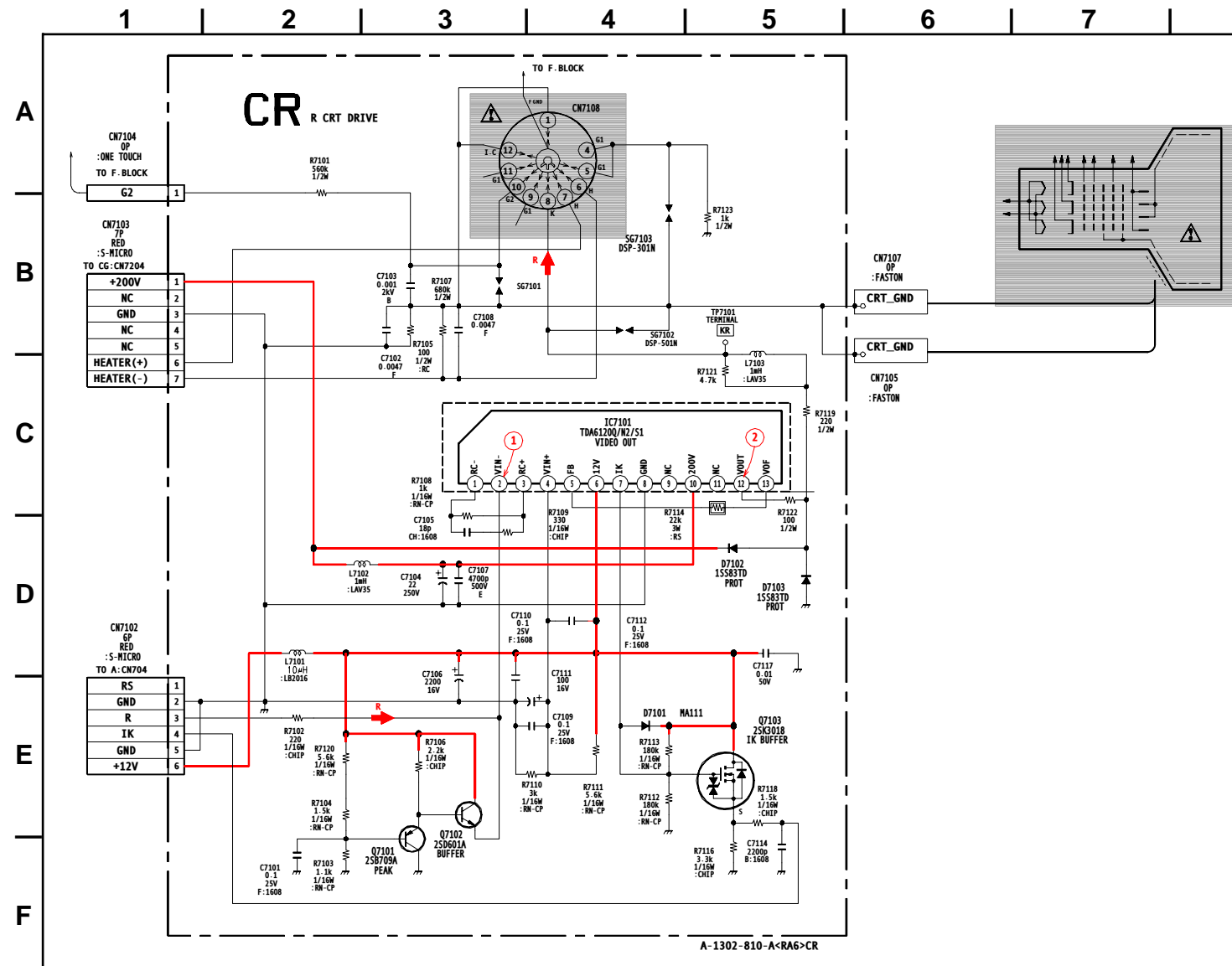

CR [R CRT DRIVE]
COMPONENT SIDE

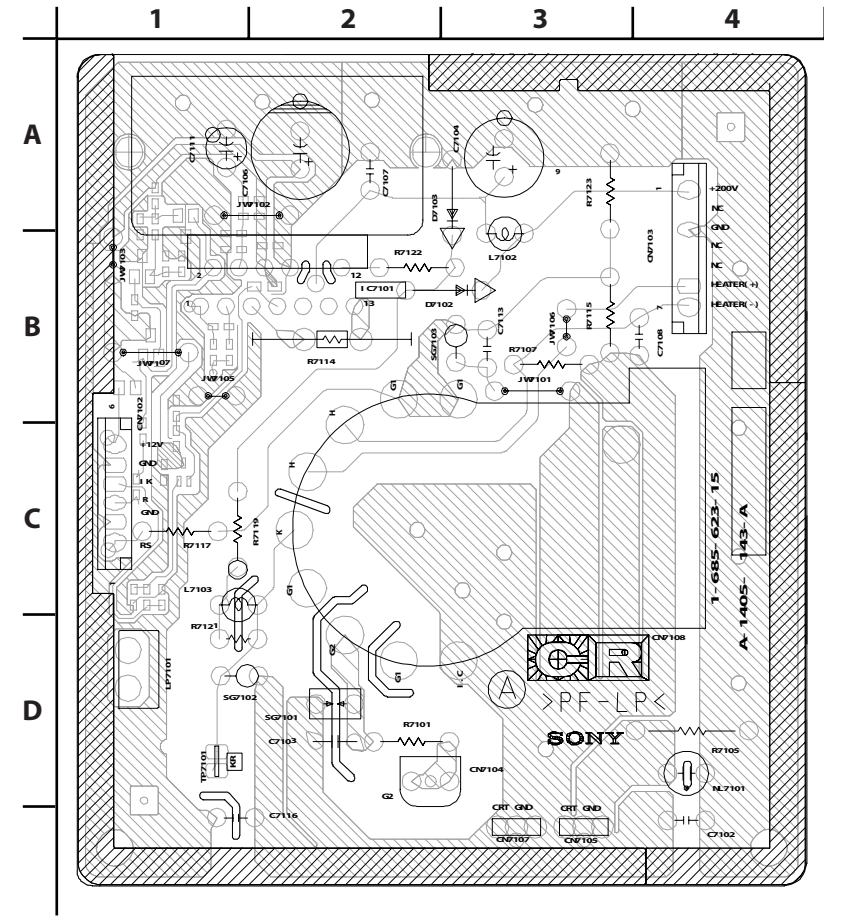

CR [R CRT DRIVE]
CONDUCTOR SIDE

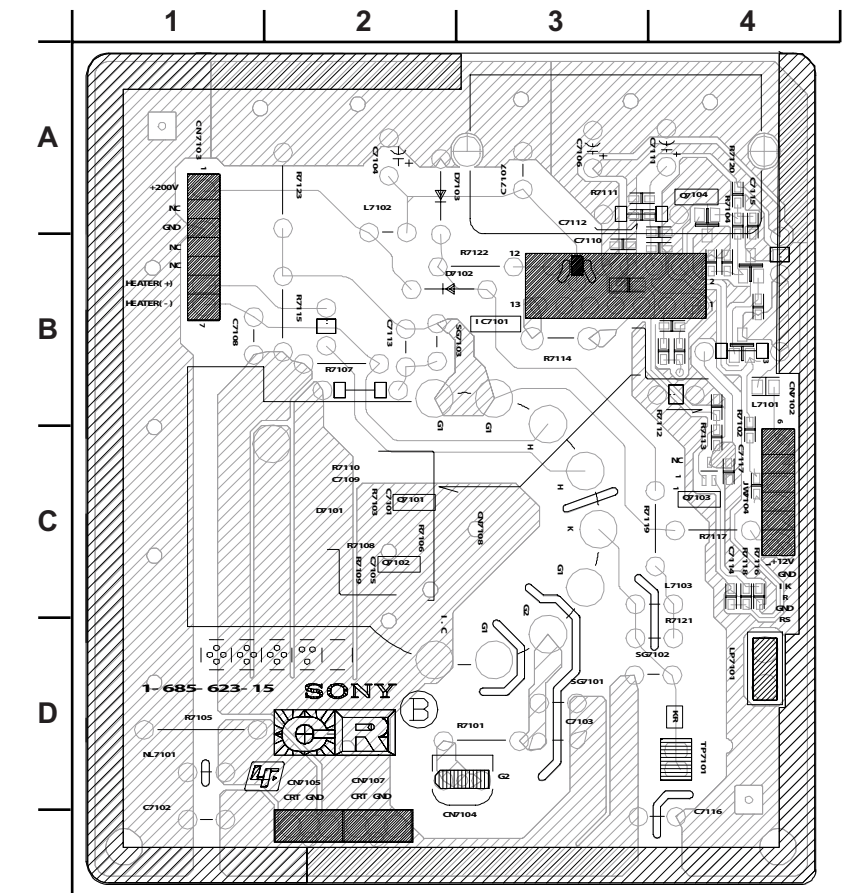

CR BOARD WAVEFORMS

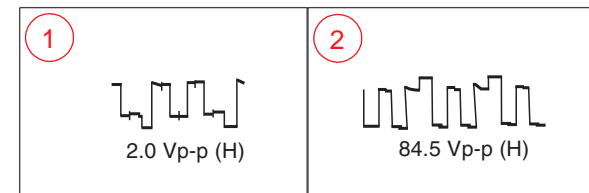

CR BOARD IC VOLTAGE LIST

IC7101			
PIN	VOLT	PIN	VOLT
1	2.0	8	GND
2	2.7	9	N/C
3	3.4	10	200.0
4	4.1	11	N/C
5	2.6	12	157.7
6	12.0	13	158.2
7	7.0		

All voltages are in V.

CR BOARD TRANSISTOR LIST

	B	C	E
Q7101	1.7	GND	2.3
Q7102	2.3	12.0	2.7

	G	D	S
Q7103	7.0	12.0	5.7

All voltages are in V.

CB BOARD SCHEMATIC DIAGRAM

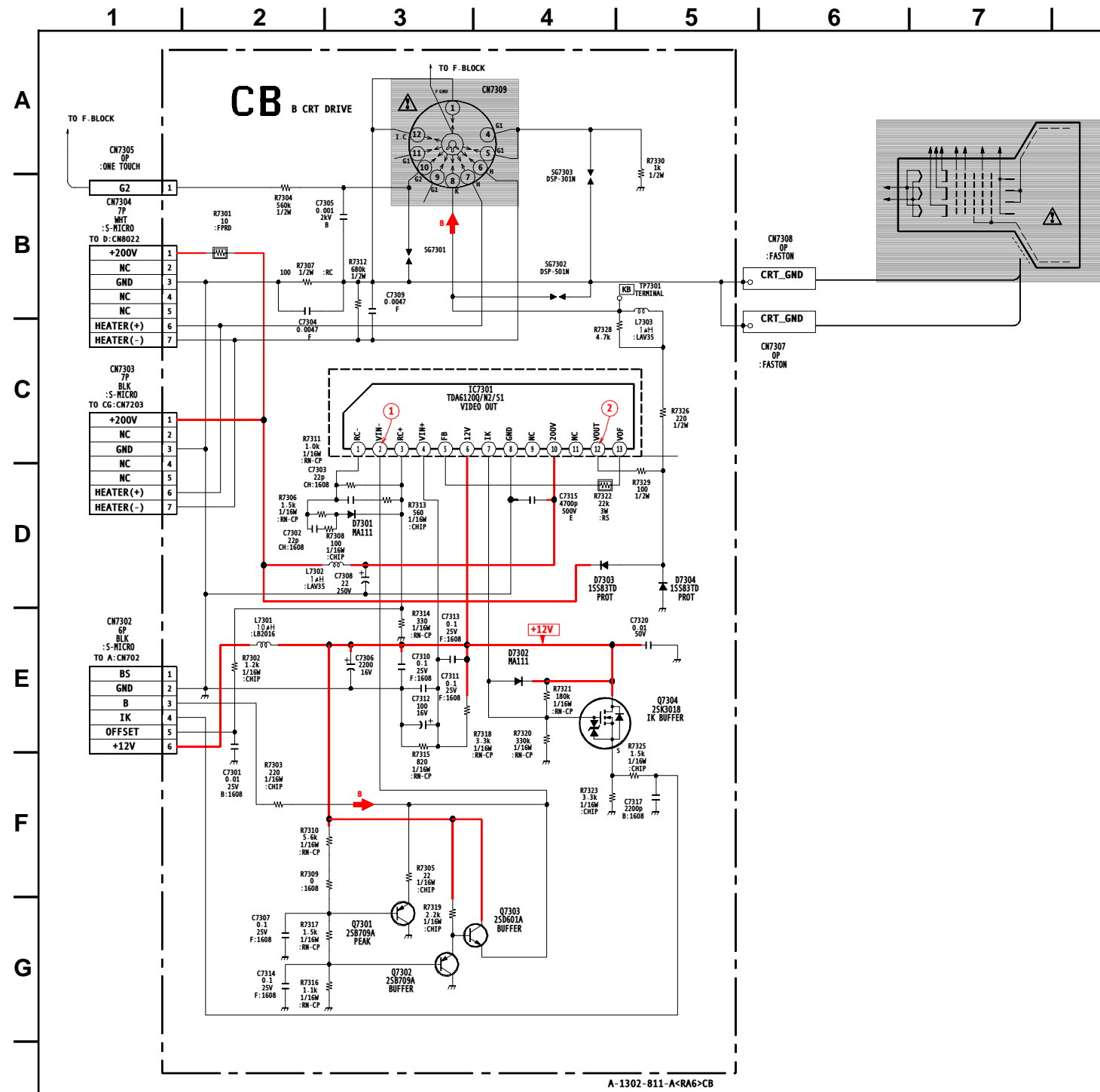

A-1302-811-A<RA6>CB

CB BOARD WAVEFORMS

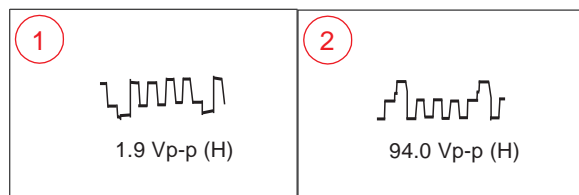

CB BOARD IC VOLTAGE LIST

IC7301			
PIN	VOLT	PIN	VOLT
1	2.1	8	GND
2	2.9	9	N/C
3	1.6	10	200.0
4	2.9	11	N/C
5	2.5	12	161.8
6	12.0	13	144.5
7	7.3		

All voltages are in V.

CB [B CRT DRIVE] COMPONENT SIDE

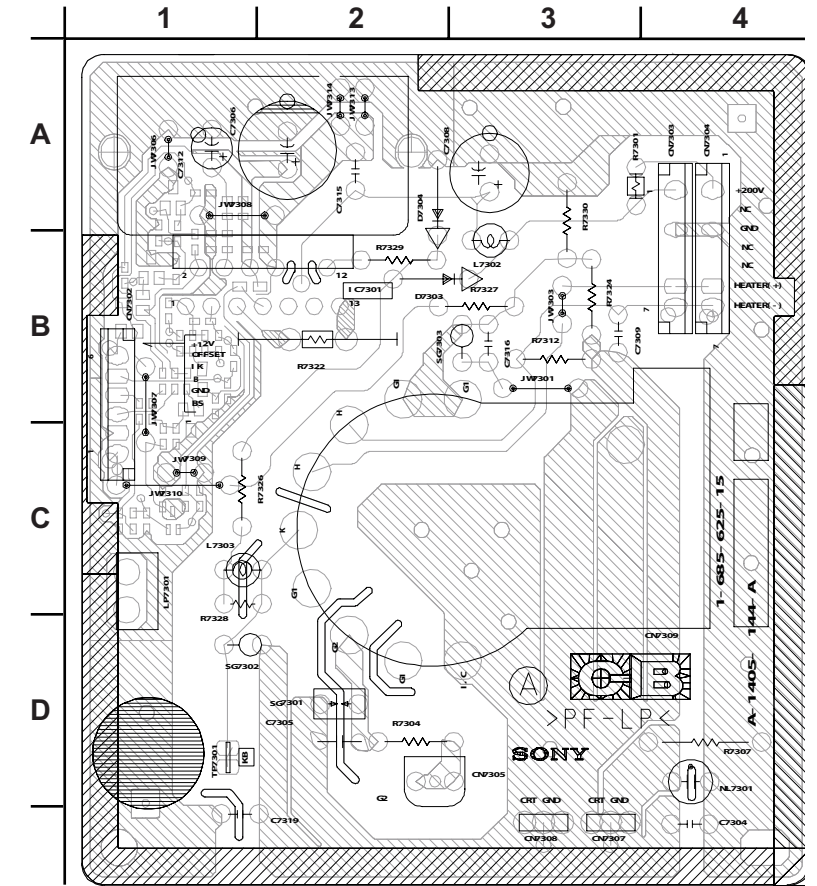

CB [B CRT DRIVE] CONDUCTOR SIDE

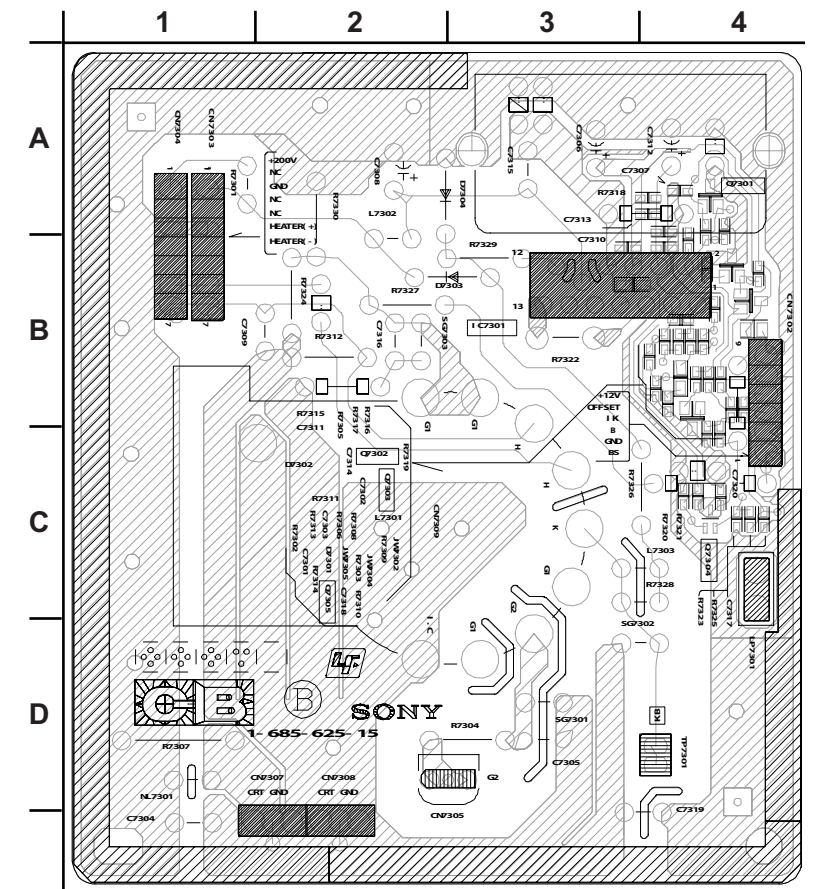

CB BOARD TRANSISTOR LIST

	B	C	E
Q7301	3.9	GND	3.0
Q7302	1.7	GND	2.4
Q7303	2.4	12.0	2.9

Q7304	G	D	S
7.3	12.0	6.0	

All voltages are in V.

CG BOARD SCHEMATIC DIAGRAM

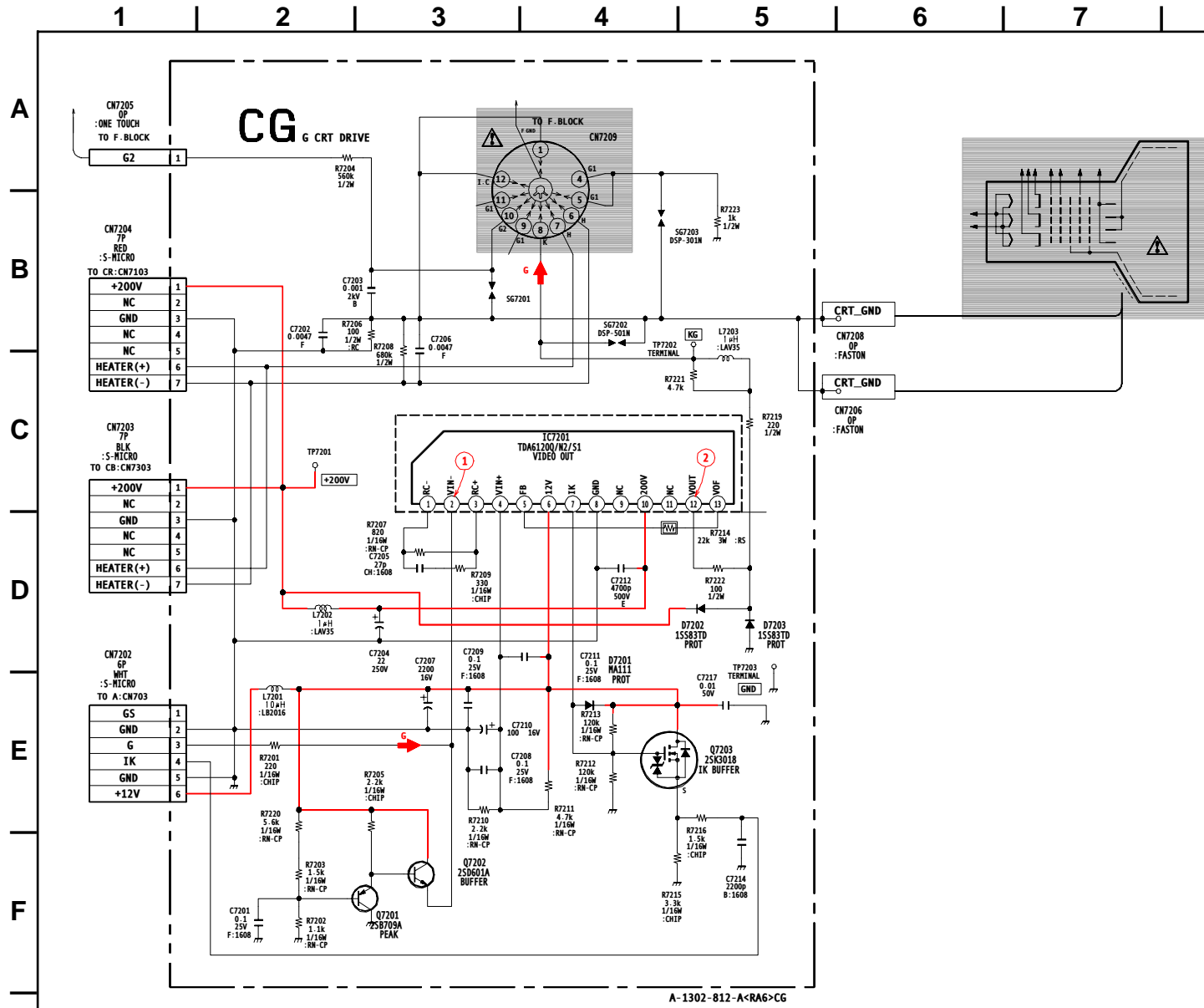

CG [G CRT DRIVE] COMPONENT SIDE

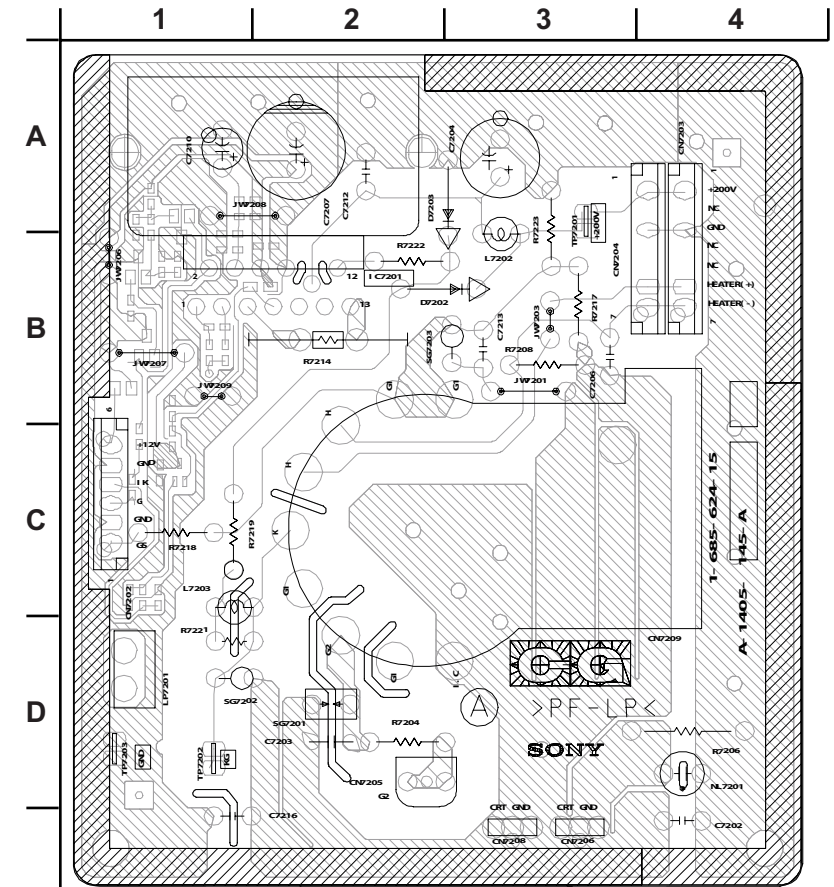

CG [G CRT DRIVE] CONDUCTOR SIDE

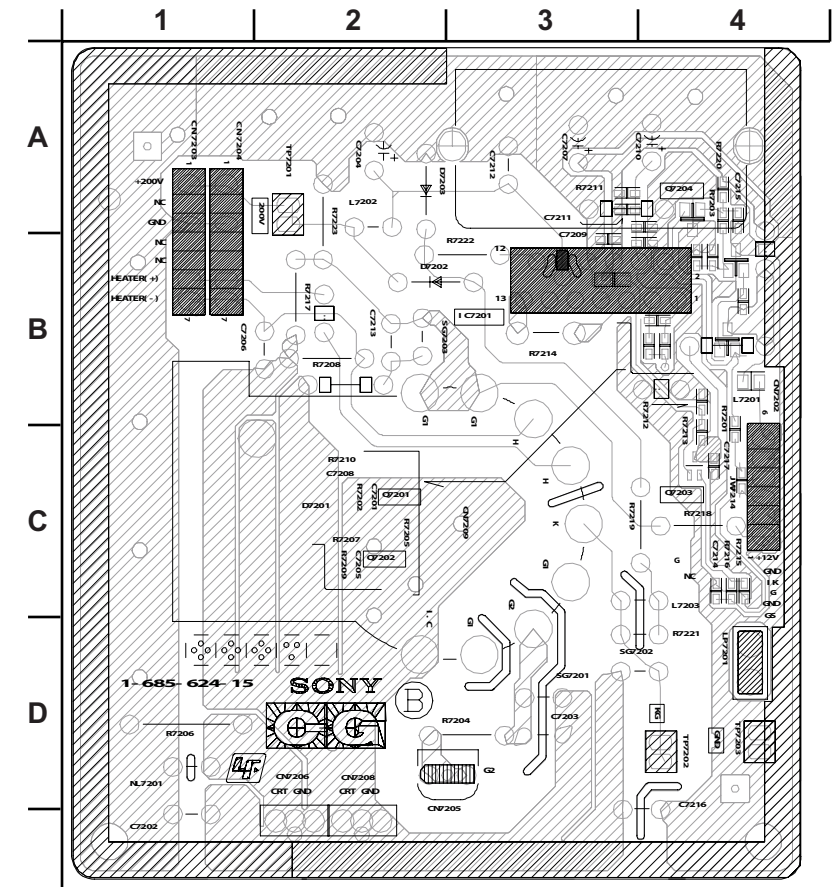

CG BOARD WAVEFORMS

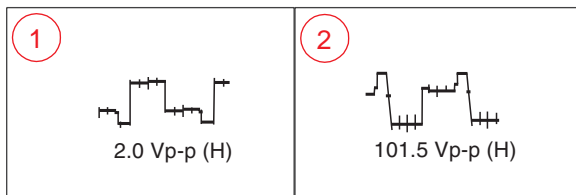

CG BOARD IC VOLTAGE LIST

IC7201			
PIN	VOLT	PIN	VOLT
1	1.9	8	GND
2	2.6	9	N/C
3	3.1	10	200.0
4	3.8	11	N/C
5	2.5	12	155.1
6	12.0	13	159.2
7	7.6		

All voltages are in V.

CG BOARD TRANSISTOR LIST

	B	C	E
Q7201	1.7	GND	2.3
Q7202	2.3	12.0	2.6
	G	D	S
Q7203	7.6	12.0	6.3

All voltages are in V.

V BOARD SCHEMATIC DIAGRAM

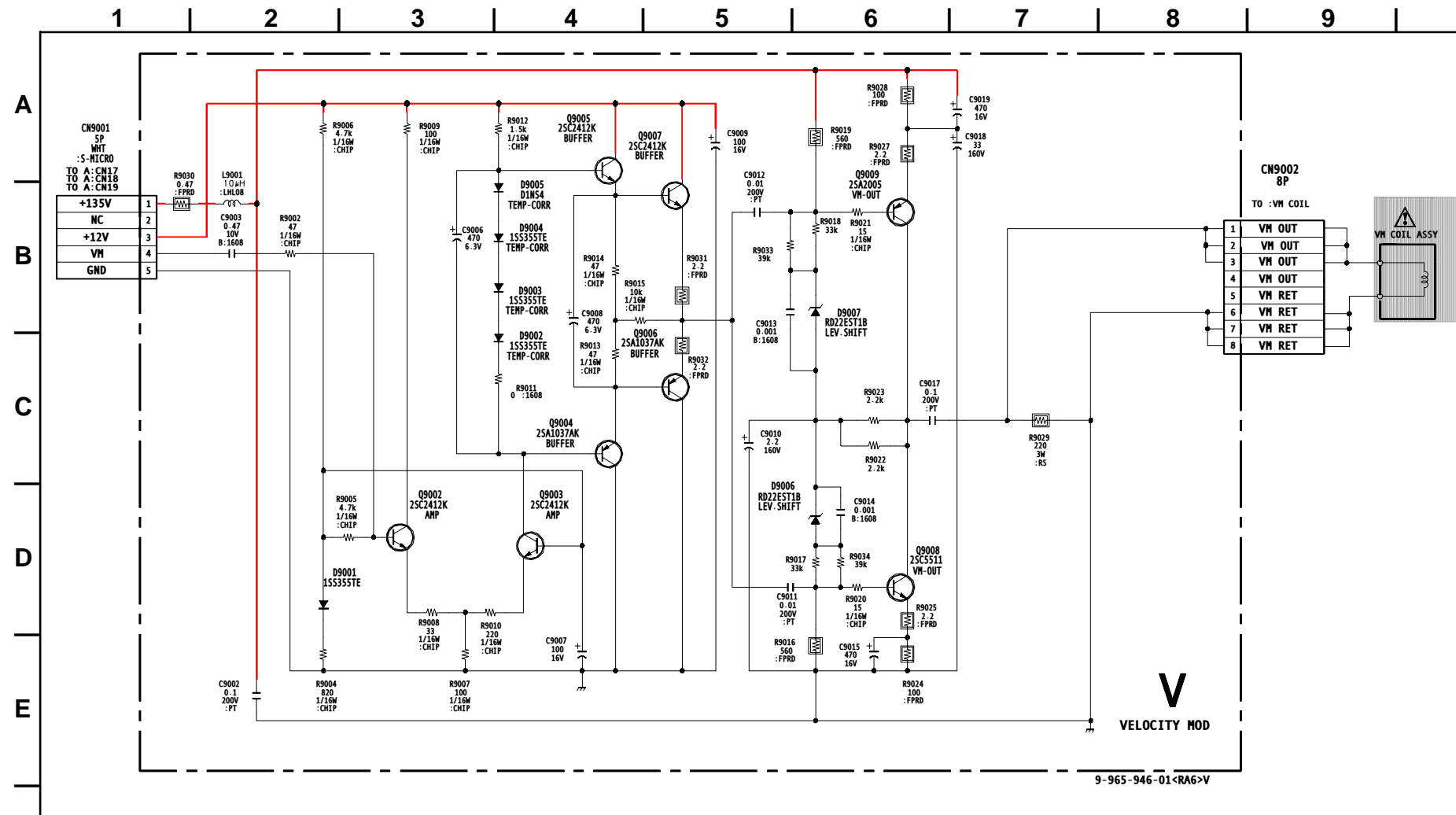

[VELOCITY MOD] COMPONENT SIDE

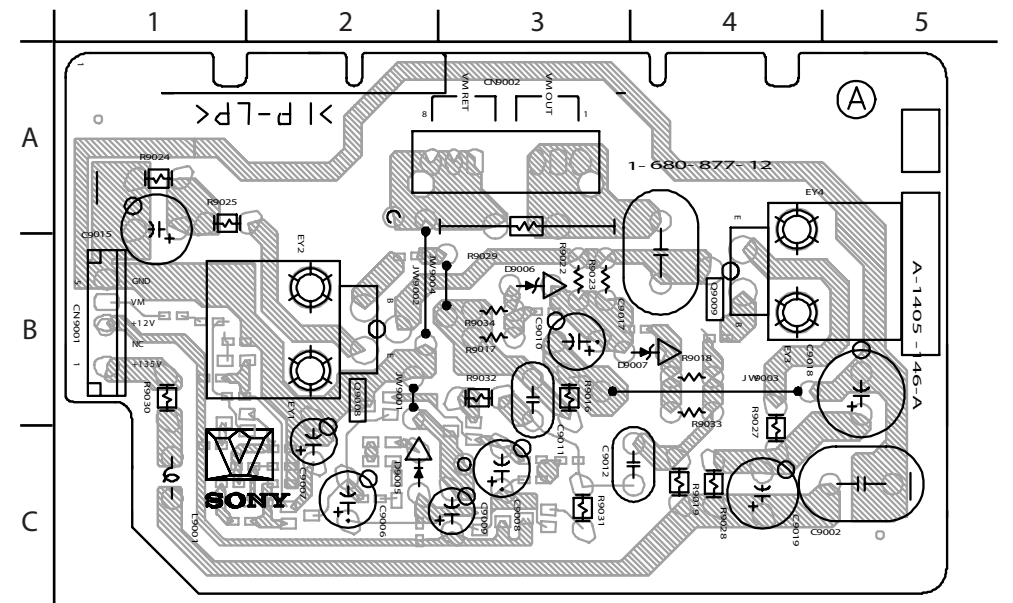

[VELOCITY MOD] CONDUCTOR SIDE

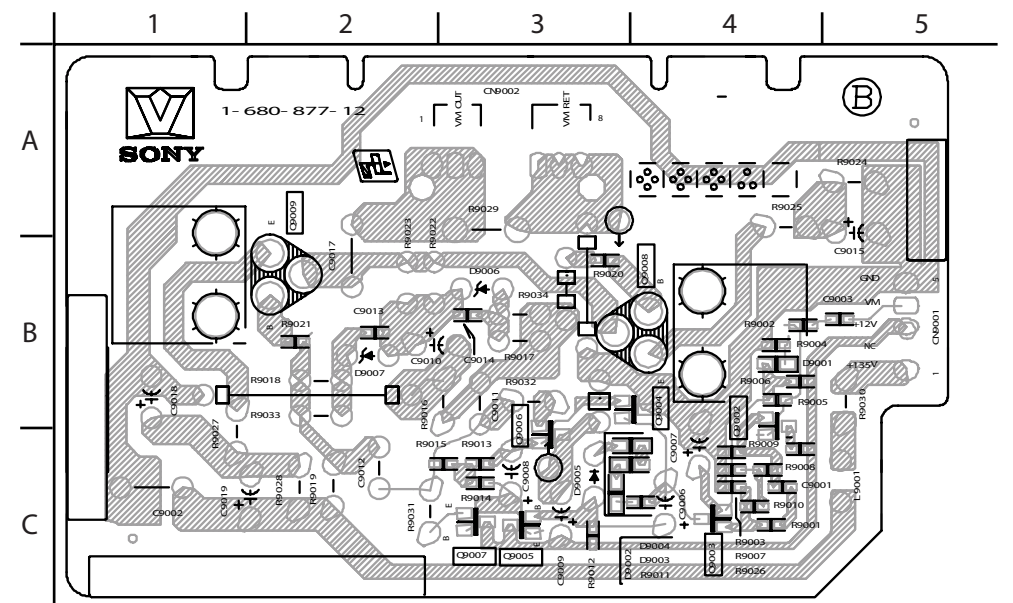

V BOARD TRANSISTOR LIST

	B	C	E
Q9002	3.3	11.9	2.7
Q9003	3.3	6.6	2.7
Q9004	6.6	7.2	GND
Q9005	9.0	12.0	8.4
Q9006	7.2	GND	7.8
Q9007	8.4	12.0	7.8
Q9008	1.4	68.0	0.8
Q9009	134.3	68.0	134.9

All voltages are in V.

G BOARD SCHEMATIC DIAGRAM

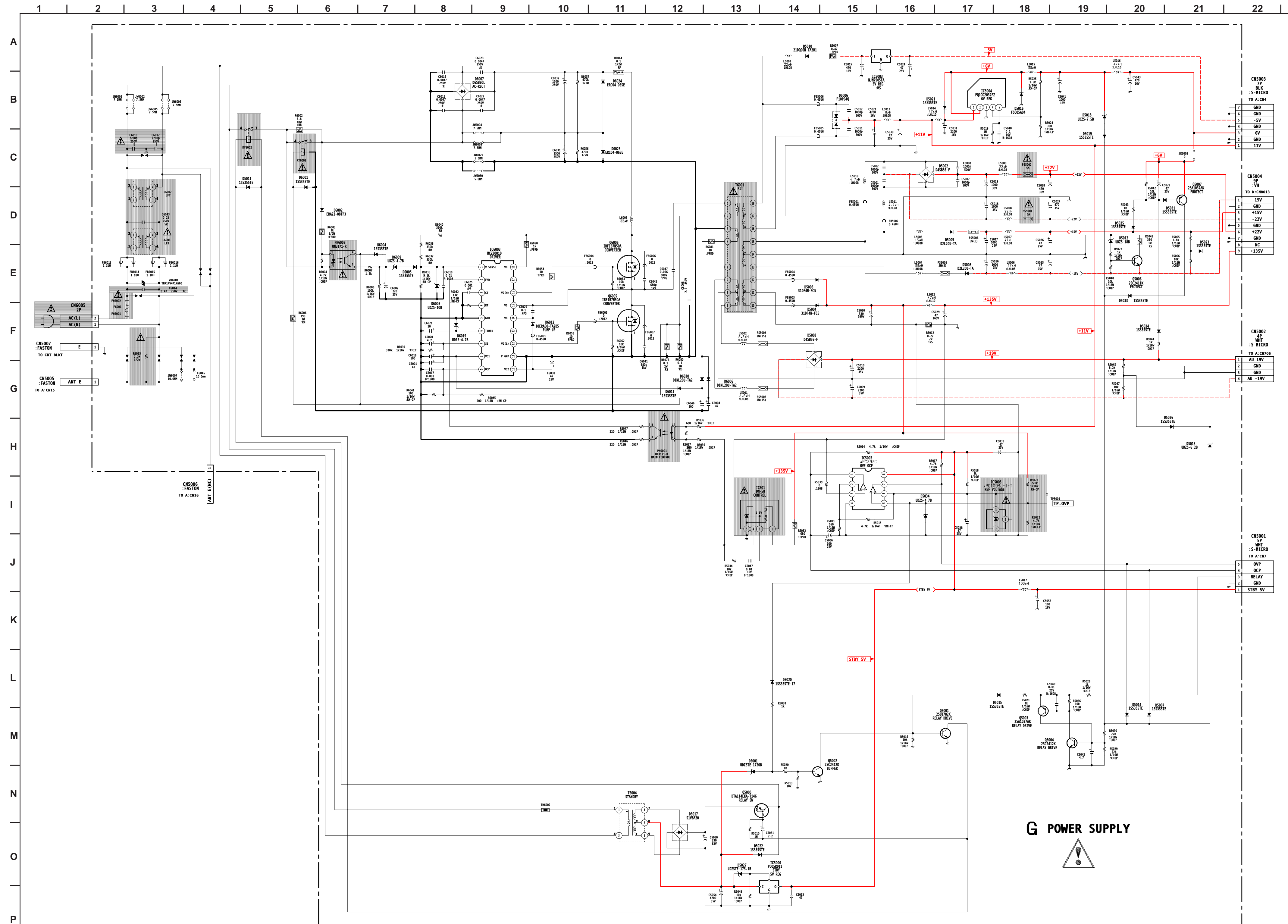

G BOARD IC VOLTAGE LIST

IC501		IC5004		IC6003	
PIN	VOLT	PIN	VOLT	PIN	VOLT
1	134.4	1	10.4	1	2.8
3	2.5	2	6.5	2	1.9
4	7.3	3	GND	3	2.2
5	GND	4	1.2	4	1.5
IC5002		5	6.7	5	GND
IC5005		IC5006		IC5007	
PIN	VOLT	PIN	VOLT	PIN	VOLT
1	-0.1	1	2.3	7	4.6
2	0.1	2	0.0	8	20.1
3	0.0	3	2.3	9	0.0
4	-0.1	3	2.3	10	10.5
5	2.2	4	GND	11	GND
6	2.3	5	6.7	12	4.9
7	-0.1	6	9.8	13	N/C
8	5.0	7	5.0	14	155.6
IC5003		8	GND	15	145.6
PIN	VOLT	16	150.6		
1	-9.0	17	N/C		
2	-5.0	18	304.5		
3	GND	All voltages are in V.			

G BOARD TRANSISTOR LIST

Q	B	C	E
Q5001	0.7	0	GND
Q5002	0.0	0.7	GND
Q5003	3.0	0.0	3.0
Q5004	0.0	3.0	GND
Q5005	22.3	9.1	22.8
Q5006	-15.0	0.0	-15.0
Q5007	6.2	0.1	6.2

Q	D	G	S
Q6005	156.0	4.9	0.0
Q6006	302.5	160.0	156.0

All voltages are in V.

G POWER SUPPLY



G [POWER SUPPLY]
COMPONENT SIDE

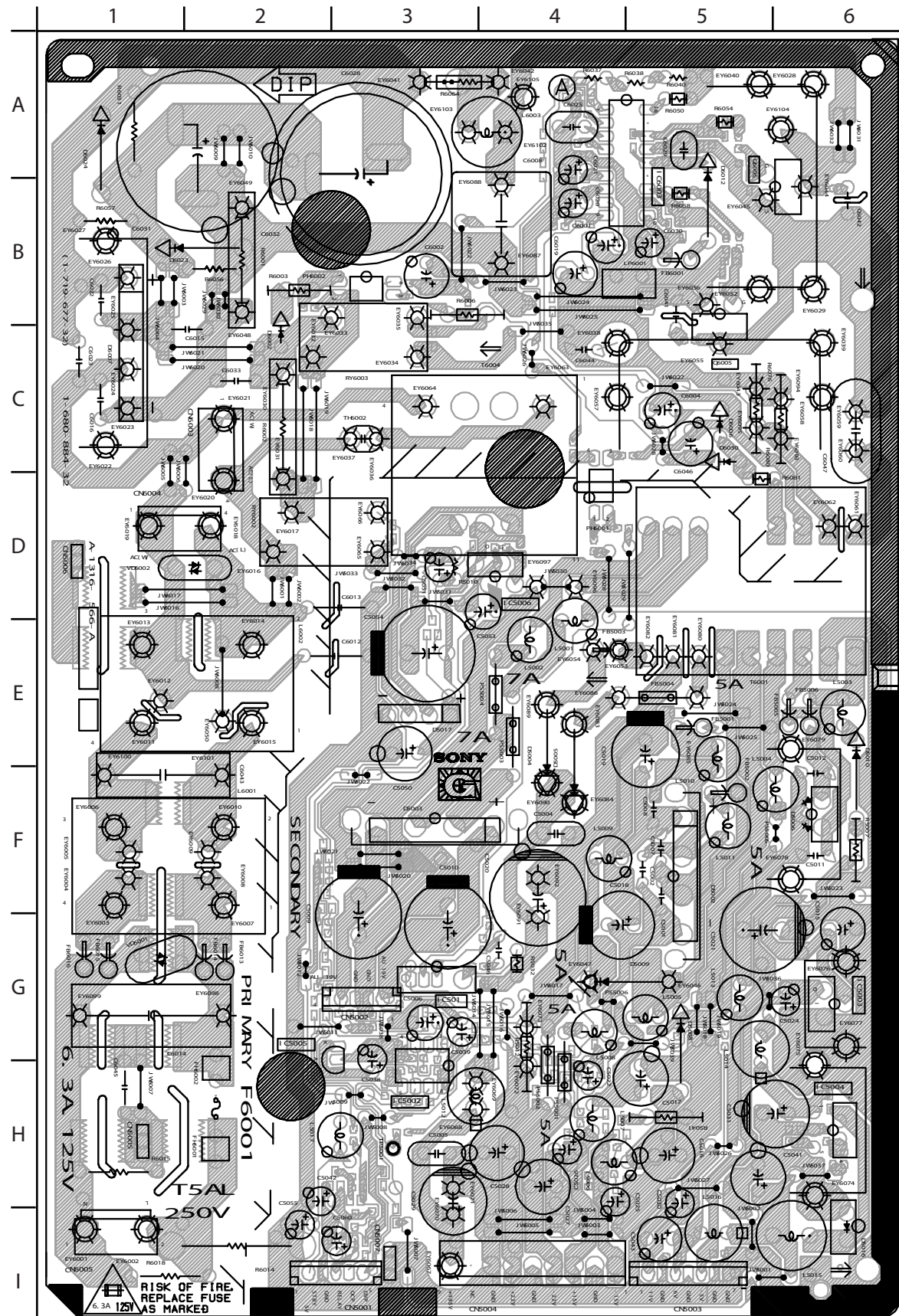

G [POWER SUPPLY]
CONDUCTOR SIDE

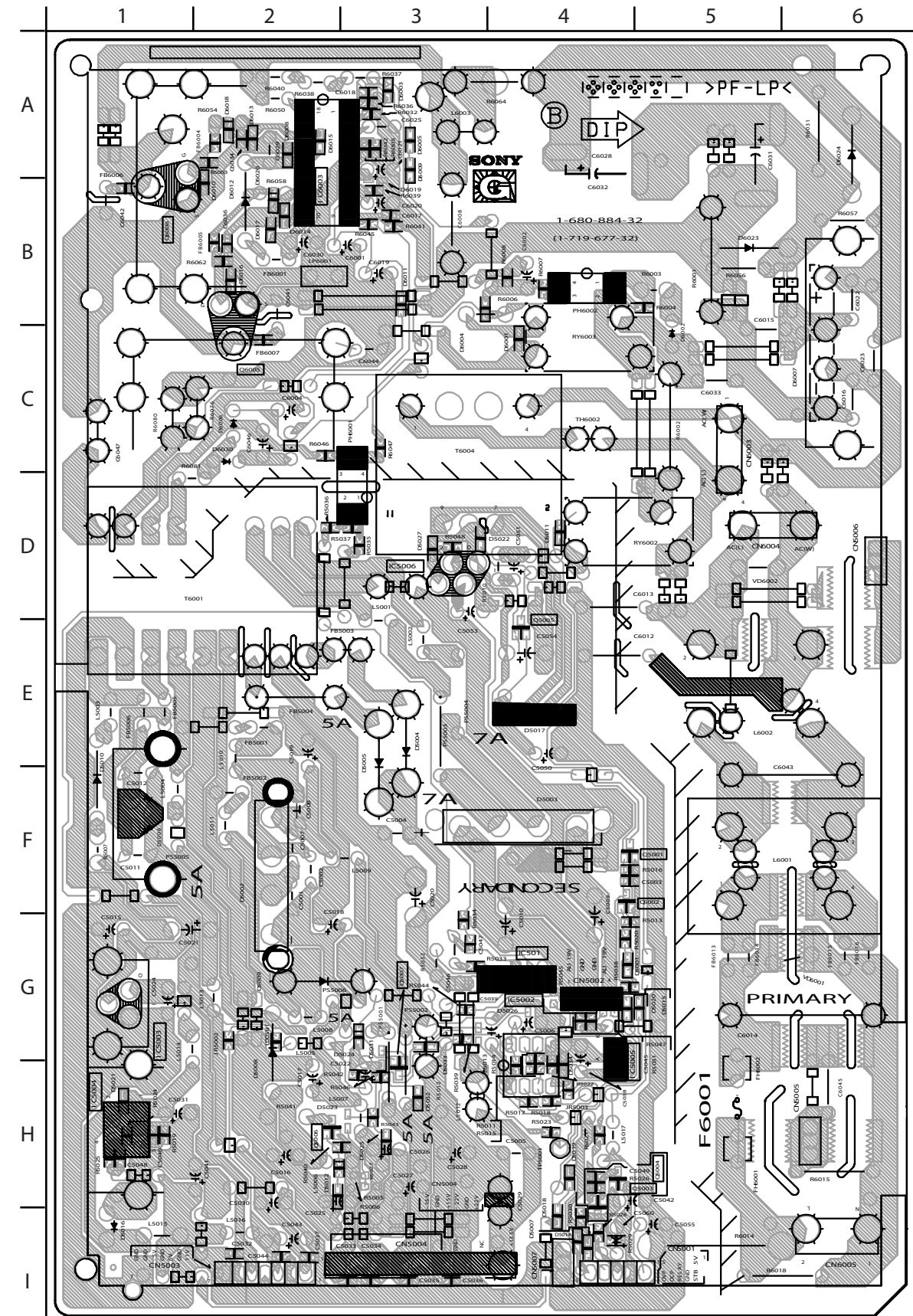

UD BOARD SCHEMATIC DIAGRAM

Due to the complexity of this board, performing component level field repairs is not recommended. If service is required, complete board replacement is the preferred repair method. Data is provided for reference only.

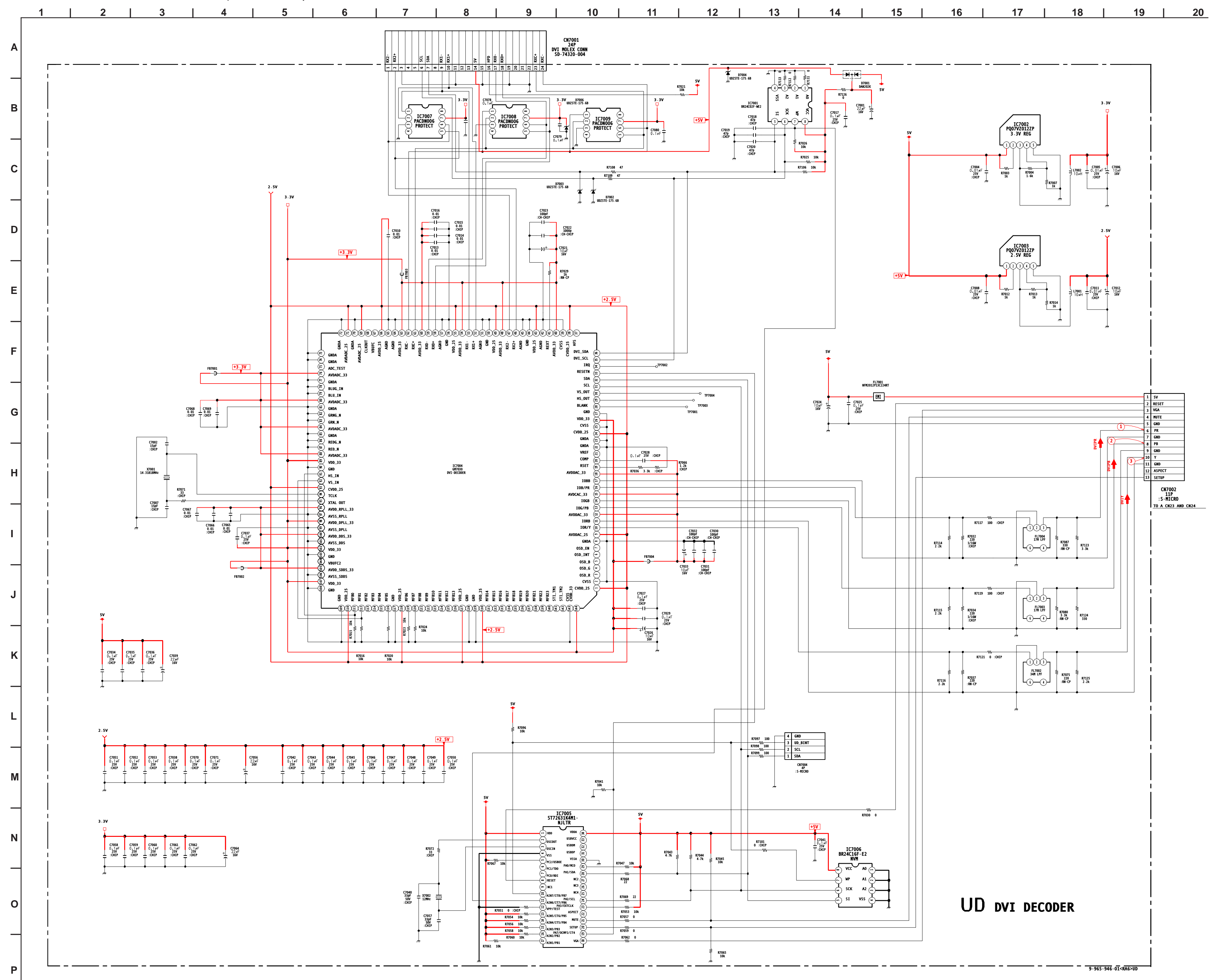

UD BOARD WAVEFORMS

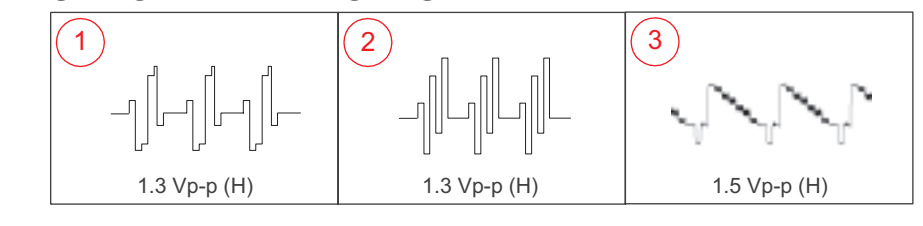

UD DVI DECODER

UD [DVI DECODER]
COMPONENT SIDE

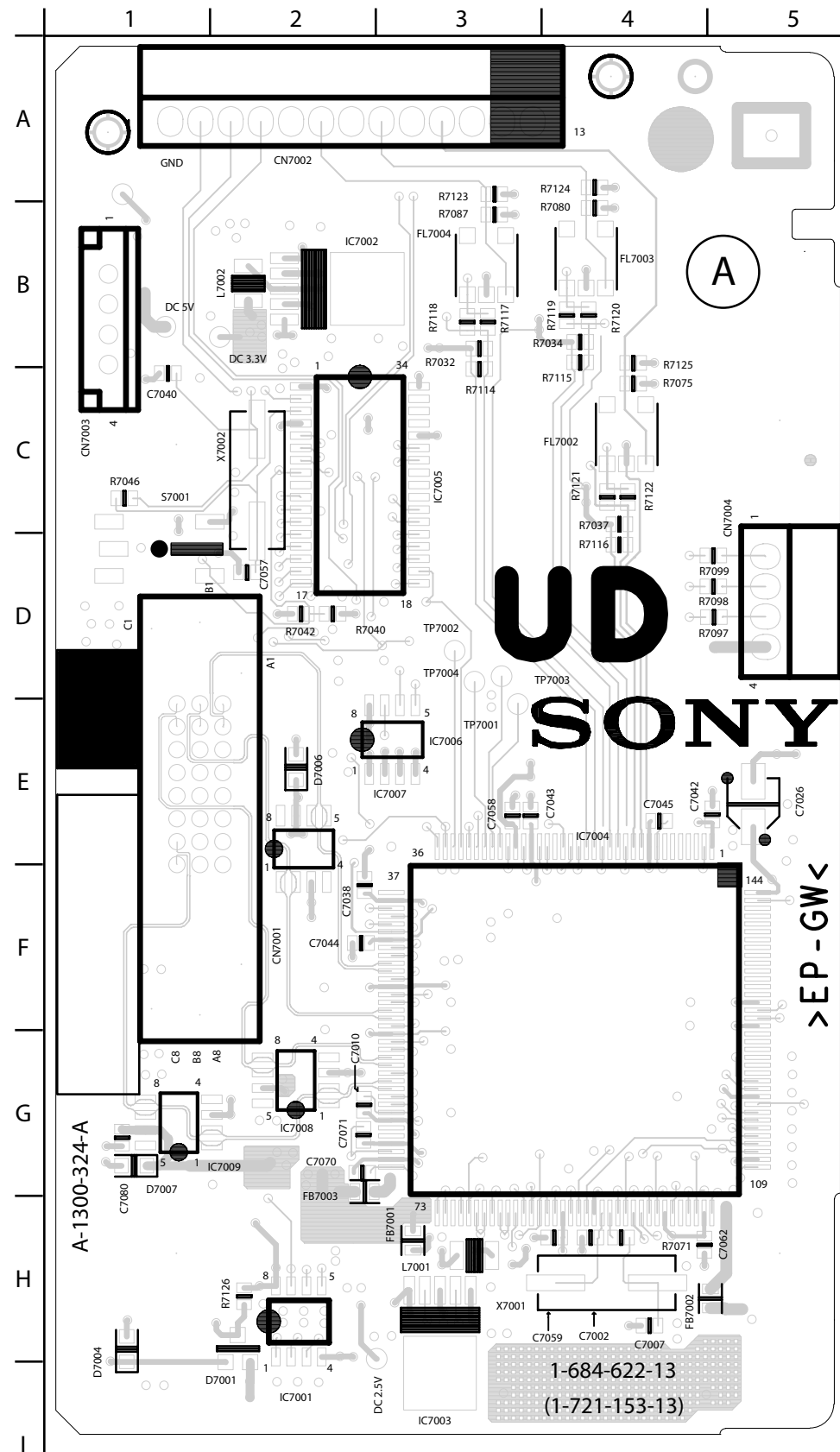

UD [DVI DECODER]
CONDUCTOR SIDE

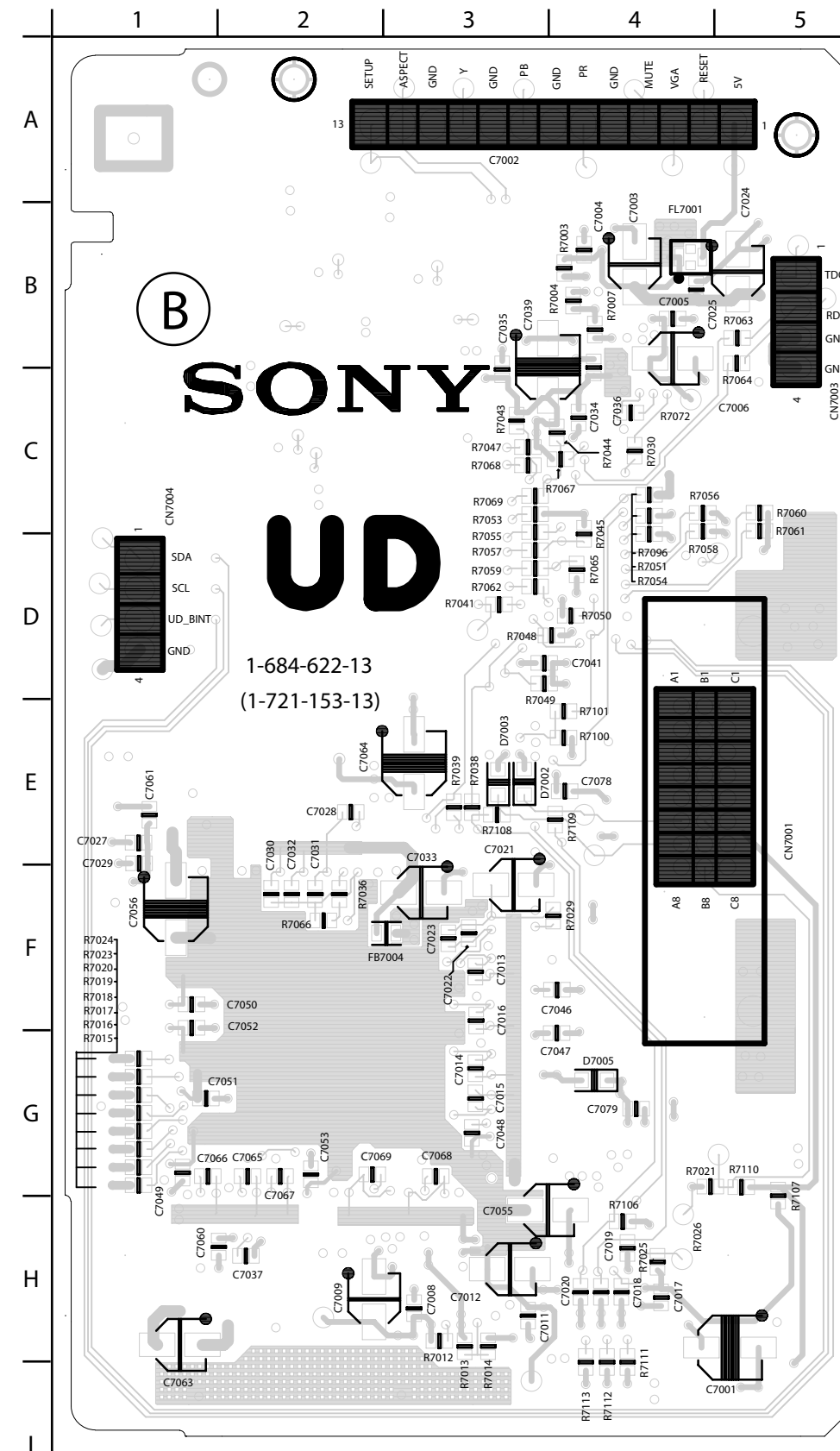

A BOARD SCHEMATIC DIAGRAM (1 OF 3)

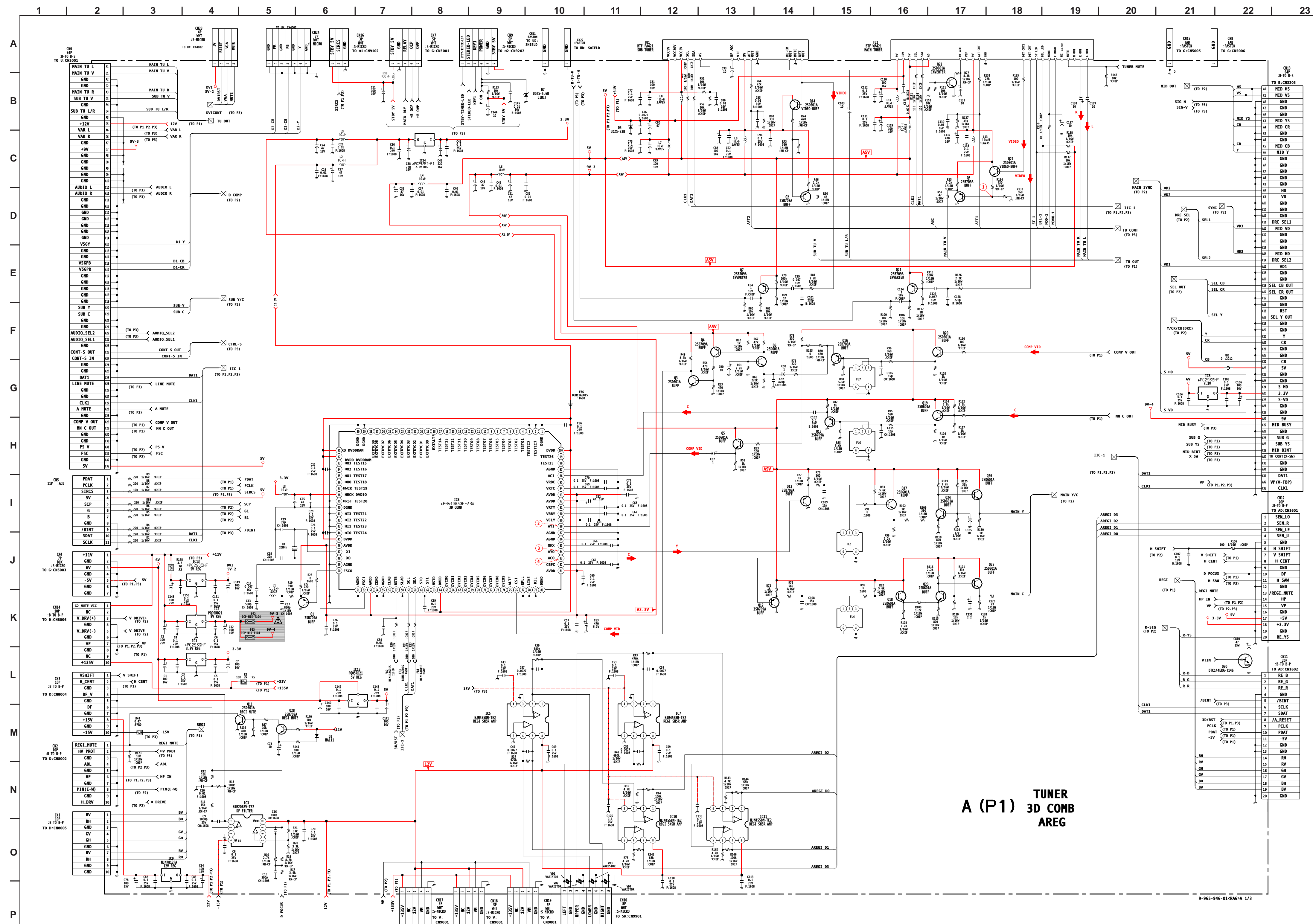

A BOARD WAVEFORMS

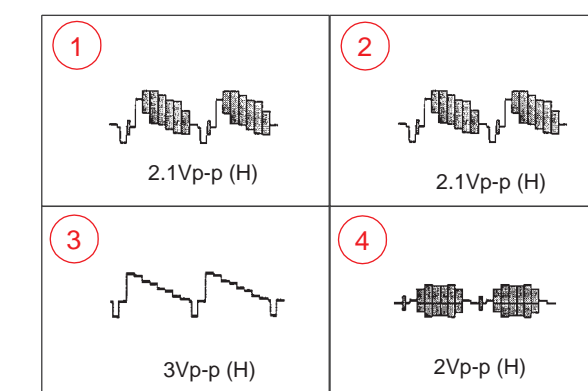

TUNER A (P1) 3D COMB AREG

A BOARD SCHEMATIC DIAGRAM (2 OF 3)

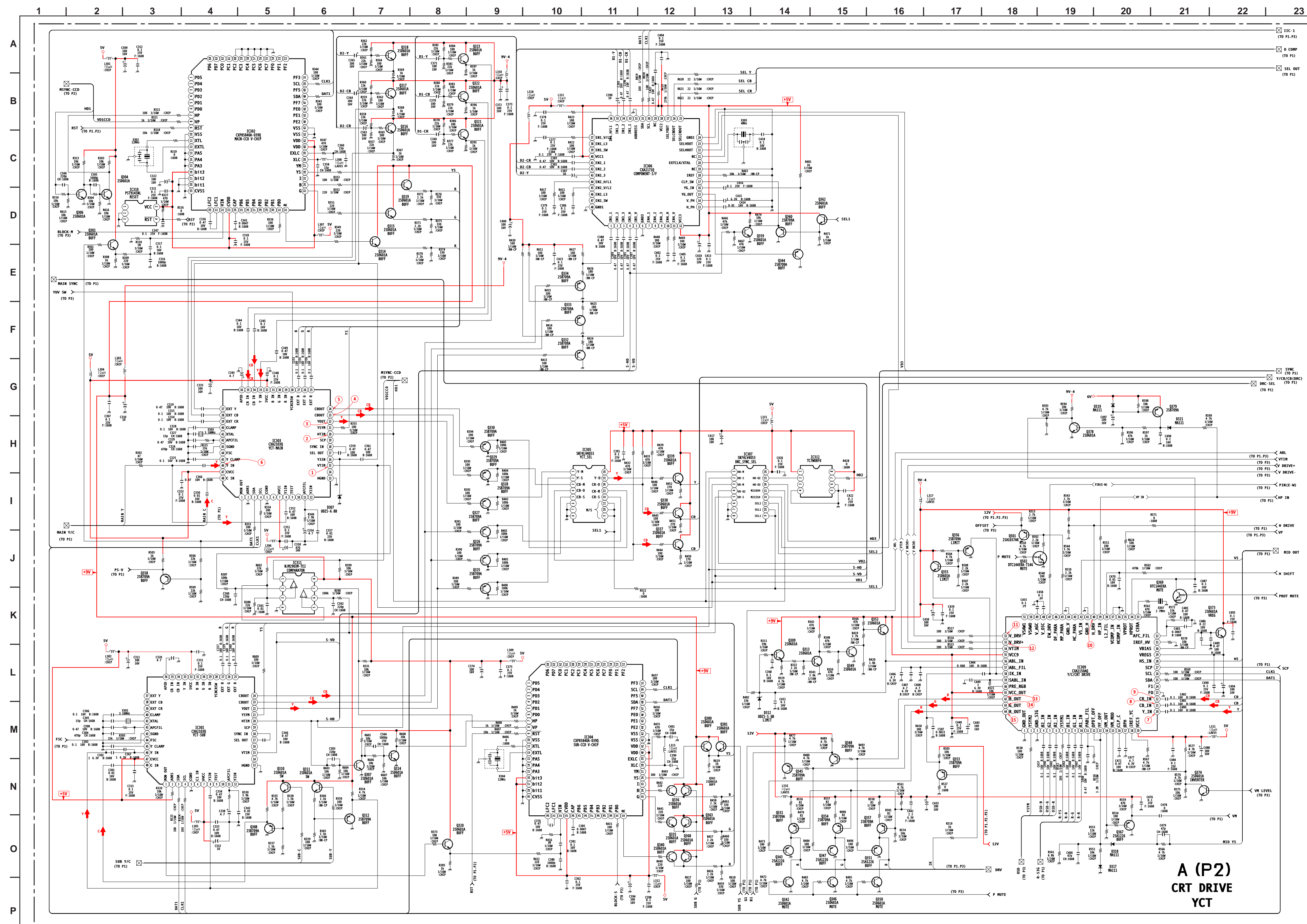

A BOARD WAVEFORMS

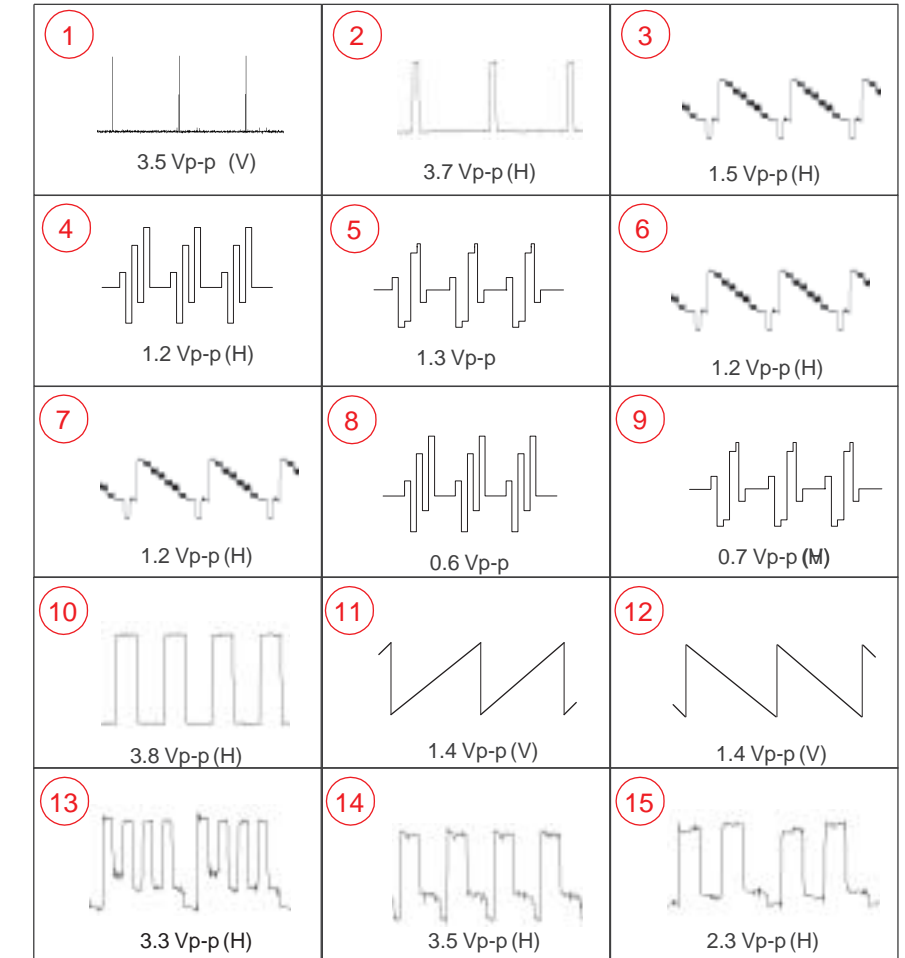

A BOARD SCHEMATIC DIAGRAM (3 OF 3)

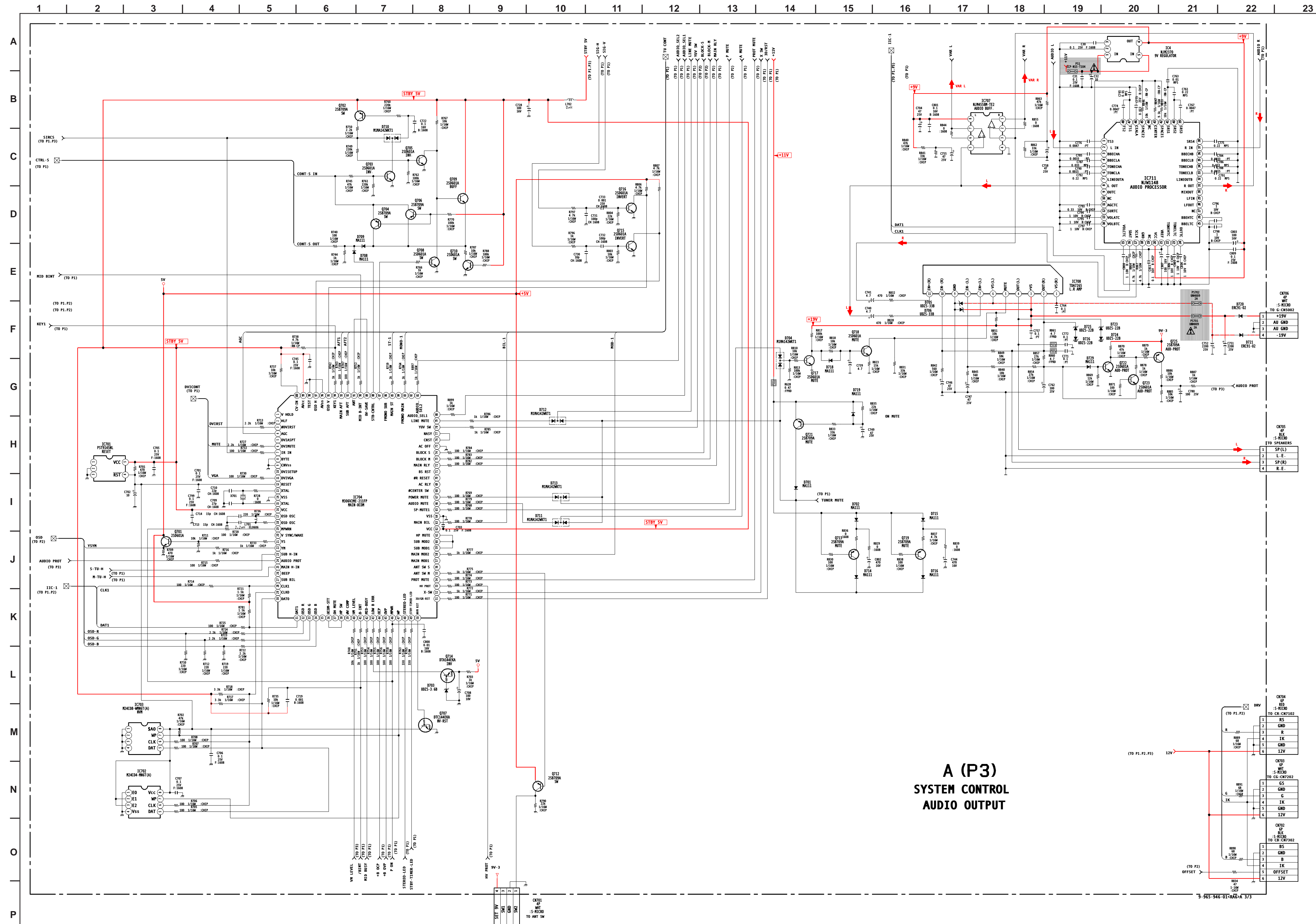

**A (P3)
SYSTEM CONTROL
AUDIO OUTPUT**

TO P1, P2, P3

1	BS
2	GND
3	G
4	IK
5	GND
6	12V

TO P1, P2, P3

1	BS
2	GND
3	B
4	IK
5	OFFSET
6	12V

A BOARD IC VOLTAGE LIST

IC1		21	NC	81	3.3	IC12		IC302		IC303		11	2.5	11	4.9	9	4.9	57	5	IC704		65	0	IC711	
PIN	VOLT	22	NC	82	1	PIN	VOLT	PIN	VOLT	PIN	VOLT	12	2.1	12	0	10	4.9	58	3.9	PIN	VOLT	66	NC	PIN	VOLT
I	6	23	NC	83	1.6	I	6	1	NC	1	1.8	13	GND	13	2.8	11	0	59	1.7	1	NC	67	0	1	4.3
O	3.3	24	NC	84	1.7	O	5	2	NC	2	GND	14	GND	14	2.9	12	0.4	60	1.7	2	NC	68	NC	2	4.3
GND	GND	25	NC	85	1	GND	GND	3	NC	3	4.4	15	GND	15	2.6	13	0.5	61	9	3	0	69	NC	3	0.0
IC2		26	NC	86	0	4	6	4	NC	4	4.4	16	5	16	5	14	0.4	62	2.7	4	0	70	NC	4	4.3
PIN	VOLT	27	NC	87	0	IC13		5	NC	5	GND	17	5	IC306		15	0.5	63	2.9	5	NC	71	NC	5	0.0
I	11	28	NC	88	1.3	PIN	VOLT	6	NC	6	NC	18	GND	PIN	VOLT	16	5	64	2.9	6	0	72	6.3	6	0.0
O	9	29	GND	89	0.5	I	11	7	0.4	7	4.8	19	GND	1	2.9	IC309		IC310		7	4.7	73	0	7	4.3
GND	GND	30	GND	90	0.9	O	5	8	5	8	2.8	20	1.7	2	2.9	PIN	VOLT	PIN	VOLT	8	GND	74	0	8	0.0
4	11	31	2.5	91	1.6	GND	GND	9	5	9	NC	21	2.6	3	2.9	1	GND	1	NC	9	GND	75	GND	9	NC
IC3		32	2.5	92	3.3	IC14		10	GND	10	NC	22	2.9	4	1.3	2	0	2	GND	10	NC	76	0	10	NC
PIN	VOLT	33	NC	93	3.3	PIN	VOLT	11	2.5	11	2.4	23	5	5	1	3	GND	3	GND	11	0	77	0	11	1.4
1	1.5	34	NC	94	3.3	I	3.3	12	2.2	12	NC	24	1.8	6	GND	4	3.1	4	5	12	4.9	78	0	12	0.8
2	0	35	NC	95	2	O	2.5	13	GND	13	GND	25	NC	7	NC	5	3.2	5	5	13	2.3	79	0	13	2.9
3	GND	36	NC	96	2.6	GND	GND	14	GND	14	NC	26	NC	8	NC	6	3.1	IC311		14	GND	80	NC	14	2.9
4	-15	37	NC	97	0	IC301		15	GND	15	0.4	27	NC	9	NC	7	0	PIN	VOLT	15	2.4	81	0	15	2.8
5	1.1	38	3.3	98	NC	PIN	VOLT	16	5	16	2.5	28	NC	10	1	8	3.6	1	5	16	4.9	82	0	16	4.6
6	1.1	39	GND	99	NC	1	2.3	17	GND	17	2	29	NC	11	1	9	0	2	0.4	17	0	83	0	17	0.0
7	0.3	40	GND	100	3.3	2	4.7	18	GND	18	3.1	30	NC	12	5	10	3.6	3	2.5	18	0	84	NC	18	GND
8	11.9	41	GND	IC7		3	4.4	19	GND	19	NC	31	0	13	4.1	11	0	4	GND	19	0	85	0	19	NC
IC4		42	GND	PIN	VOLT	4	4.5	20	1.7	20	0	32	0	14	4.1	12	0.4	5	2.5	20	NC	86	NC	20	9.0
PIN	VOLT	43	GND	1	0.1	5	GND	21	2.6	21	0	33	0	15	3.2	13	0.4	6	0.5	21	0	87	0	21	4.3
1	11.0	44	GND	2	0	6	NC	22	2.4	22	1.8	34	0	16	2.8	14	2.5	7	5	22	0	88	0	22	3.3
2	GND	45	2.5	3	GND	7	5	23	5	23	2.1	35	NC	17	3.2	15	3.8	8	5	23	0	89	0	23	3.3
3	0.0	46	3.3	4	-15	8	3	24	1.6	24	2.2	36	0	18	1	16	2.6	IC312		24	GND	90	0	24	4.9
4	9.0	47	1.7	5	GND	9	NC	25	NC	25	3.6	37	NC	19	NC	17	2.6	PIN	VOLT	25	0	91	0	25	0.0
5	11.0	48	1.5	6	0	10	NC	26	NC	26	3.6	38	2.5	20	2.9	18	1.1	1	5	26	NC	92	0	26	3.3
IC5		49	GND	7	0.2	11	2.4	27	NC	27	3.6	39	2.5	21	NC	19	5	2	0.5	27	NC	93	0	27	NC
PIN	VOLT	50	1.4	8	12	12	NC	28	NC	28	2.9	40	5	22	0.4	20	3.6	3	NC	28	4.4	94	4.6	28	NC
1	0	51	GND	IC8		13	GND	29	NC	29	NC	41	5	23	0.1	21	0	4	GND	29	4.9	95	4.6	29	NC
2	0	52	0	PIN	VOLT	14	NC	30	NC	30	NC	42	GND	24	GND	22	3.1	5	GND	30	4.9	96	GND	30	NC
3	GND	53	3.3	I	6	15	0.5	31	0	31	NC	43	GND	25	2.6	23	GND	6	GND	31	4.4	97	4.6	31	4.3
4	-15	54	GND	O	3.3	16	NC	32	0	32	5	44	NC	26	2.6	24	NC	7	HD2	32	0	98	GND	32	NC
5	GND	55	GND	G	GND	17	0	33	0	33	3.2	45	NC	27	2.6	25	4.4	8	5	33	0	99	4.9	33	4.3
6	0	56	NC	IC9		18	3.4	34	0	34	3.2	46	NC	28	5	26	4.4	IC701		34	0	100	4.6	34	0.0
7	0.1	57	5	PIN	VOLT	19	NC	35	NC	35	3.2	47	NC	29	NC	27	0.7	PIN	VOLT	35	NC	IC707		35	4.3
8	12	58	GND	I	15	20	0.5	36	0	36	3.2	48	SDA	30	4.4	28	0.2	1	NC	36	0	PIN	VOLT	36	4.3
IC6		59	4.5	O	12	21	0	37	NC	37	3.6	49	NC	31	4.4	29	5	2	GND	37	4.6	1	4.8	37	4.3
PIN	VOLT	60	4.5	GND	GND	22	2.1	38	2.6	38	3.2	50	SCL	32	GND	30	5.7	3	GND	38	0	2	4.5	38	0.0
1	GND	61	NC	IC10		23	2.2	39	2.6	39	3.3	51	NC	33	2.9	31	1.3	4	5	39	0	3	4.5	39	4.3
2	GND	62	NC	PIN	VOLT	24	2.2	40	5	40	1.7	52	NC	34	2.9	32	3.1	5	5	40	0	4	GND	40	4.3
3	GND	63	NC	1	0.1	25	3.5	41	5	41	1.8	53	NC	35	2.9	33	1.6	IC702		41	2.3	5	4.6	41	0.0
4	NC	64	3.3	2	0	26	3.5	42	GND	42	2.6	54	NC	36	1	34	0	PIN	VOLT	42	0	6	4.5	42	4.3
5	NC	65	NC	3	0	27	3.5	43	GND	43	GND	55	NC	37	1	35	0.3	1	GND	43	4.6	7	4.8	43	4.3
6	NC	66	NC	4	-15	28	NC	44	NC	44	2.5	56	NC	38	NC	36	GND	2	5	44	2.8	8	9	44	NC
7	NC	67	NC	5	0.1	29	NC	45	NC	45	3.2	57	NC	39	NC	37	2.7	3	5	45	0.1	IC708		45	4.3
8	NC	68	NC	6	0	30	NC	46	NC	46	2.8	58	NC	40	5	38	3.3	4	GND	46	0	PIN	VOLT	46	4.3
9	NC	69	NC	7	1	31	NC	47	NC	47	5	59	NC	41	2.9	39	0.7	5	4.4	47	4.6	1	-19	47	4.3
10	NC	70	NC	8	12	32	5	48	4.4	48	3.2	60	NC	42	2.8	40	3	6	4.4	48	5	2	0	48	4.3
11	NC	71	NC	IC11		33	NC	49	NC	IC304		61	NC	43	2.1	41	GND	7	5	49	5	3	22.1	All voltages are in V.	
12	NC	72	NC	1	1.2	34	NC	50	4.3	PIN	VOLT	62	NC	44	1	42	0	8	5	50	0	4	0		
13	NC	73	NC	2	0.1	35	NC	51	NC	1	NC	63	NC	45	1	43	2.5	IC703		51	5	5	11.6		
14	NC	74	NC	3	0.3	36	2.7	52	NC	2	NC	64	NC	46	NC	44	GND	PIN	VOLT	52	0	6	-19		
15	NC	75	NC	4	-15	37	NC	53	NC	3	NC	IC305		47	NC	45	2.1	1	GND	53	2.8	7	0		
16	NC	76	4.1	5	0.2	38	NC	54	NC	4	NC	PIN	VOLT	48	GND	46	NC	2	GND	54	0	8	0		
17	NC	77	GND	6	0	39	NC	55	GND	5	NC	1	2.4	IC307		47	3.9	3	GND	55	0	9	0		
18	NC	78	GND	7	2	40	1.7	56	GND	6	NC	2	0	PIN	VOLT	48	4.4	4	GND	56	NC	10	0		
19	NC	79	GND	8	12	41	1.8	57	GND	7	0.4	3	2.8	1	0.5	49	5.4	5	4.4	57	NC	11	0		
20	NC	80	GND	42	2.6	58	GND	8	5	4	2.9	2	0.5	50	NC	6	4.4	58	0	64	GND				

A

[TUNER, 3D COMB, AREG, CRT DRIVE, YCT, SYSTEM CONTROL, AUDIO OUTPUT]

COMPONENT SIDE

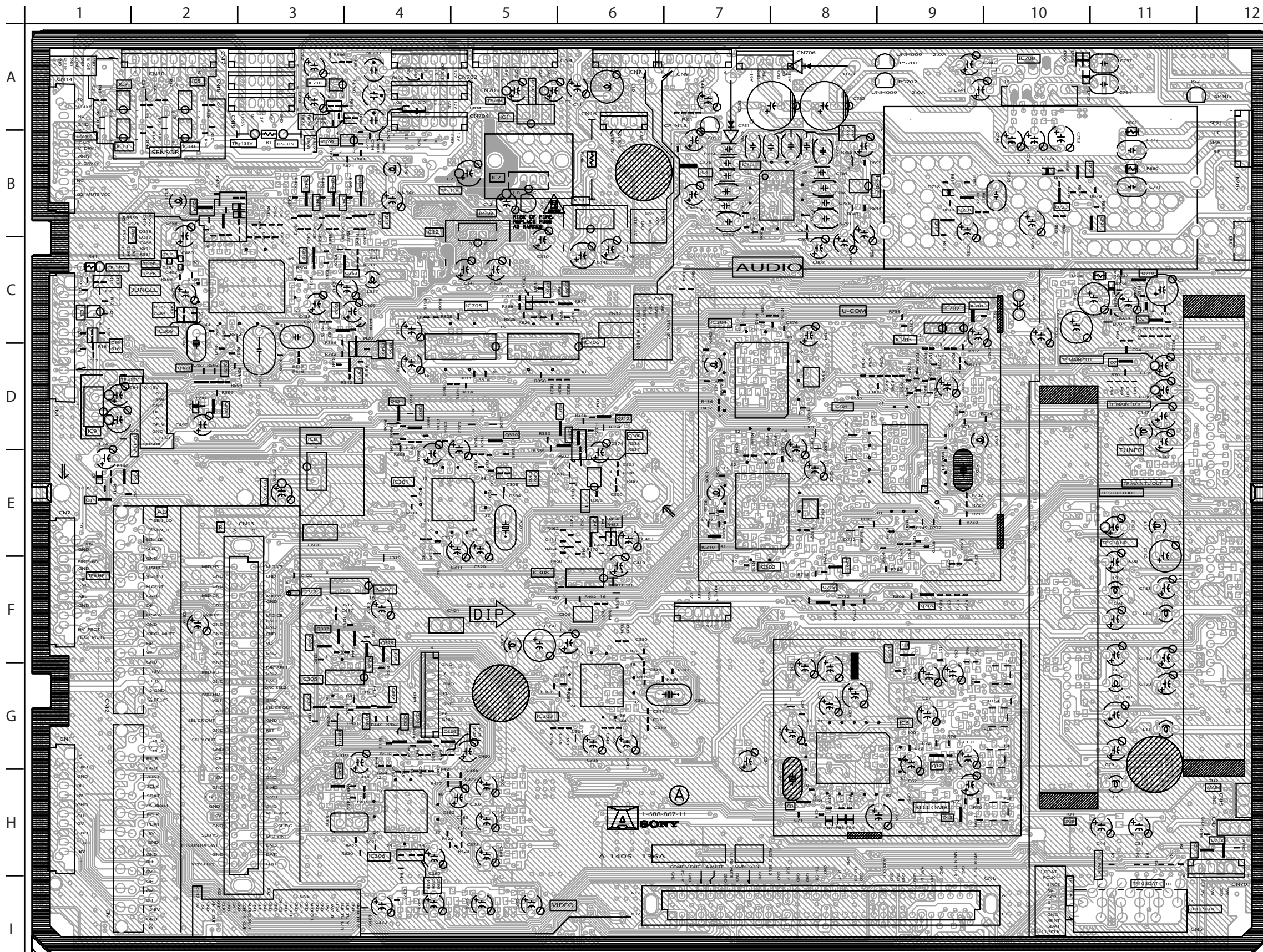

A BOARD LOCATOR LIST

DIODE		TRANSISTOR		TRANSISTOR	
D1	E-1	Q1	H-8	Q703	F-8
D317	C-2	Q3	F-9	Q712	H-12
D318	C-2	Q7	D-11	Q715	F-8
D319	D-2	Q11	E-1	Q716	F-9
D701	C-11	Q12	G-9	Q717	B-9
D704	C-11	Q13	H-9	Q718	B-9
D705	A-10	Q21	C-11	Q722	B-10
D710	F-9	Q302	F-7	Q723	B-10
D711	E-8	Q303	F-7	Q725	B-11
D712	E-8	Q305	F-6		
D713	D-8	Q307	D-4		
D718	B-9	Q308	B-6		
D725	A-10	Q310	D-5		
D726	A-10	Q311	D-5		
D729	B-10	Q312	D-6		
		IC	Q313	D-4	
IC1	A-5	Q320	D-5		
IC2	B-5	Q324	D-4		
IC3	C-1	Q325	F-4		
IC4	G-9	Q326	F-4		
IC5	A-2	Q327	G-3		
IC6	G-9	Q328	F-4		
IC7	A-2	Q329	F-4		
IC8	D-3	Q330	G-3		
IC9	D-1	Q332	G-4		
IC10	B-2	Q333	G-4		
IC11	B-1	Q334	G-4		
IC12	B-4	Q337	F-3		
IC13	B-6	Q338	G-4		
IC301	E-4	Q339	G-4		
IC302	F-7	Q341	E-6		
IC303	G-5	Q342	B-3		
IC304	C-7	Q343	B-3		
IC305	G-3	Q344	G-3		
IC306	H-4	Q346	B-3		
IC307	F-4	Q347	B-3		
IC308	F-5	Q349	D-4		
IC309	C-2	Q350	B-4		
IC310	E-7	Q351	B-4		
IC311	E-6	Q352	C-3		
IC312	F-3	Q353	C-4		
IC701	C-9	Q355	C-3		
IC702	C-9	Q367	C-1		
IC703	C-9	Q369	D-2		
IC704	D-8	Q374	B-2		
IC707	B-8	Q378	D-2		
IC708	A-10	Q379	D-2		
IC711	B-8				

A

[TUNER, 3D COMB, AREG, CRT DRIVE, YCT, SYSTEM CONTROL, AUDIO OUTPUT]

CONDUCTOR SIDE

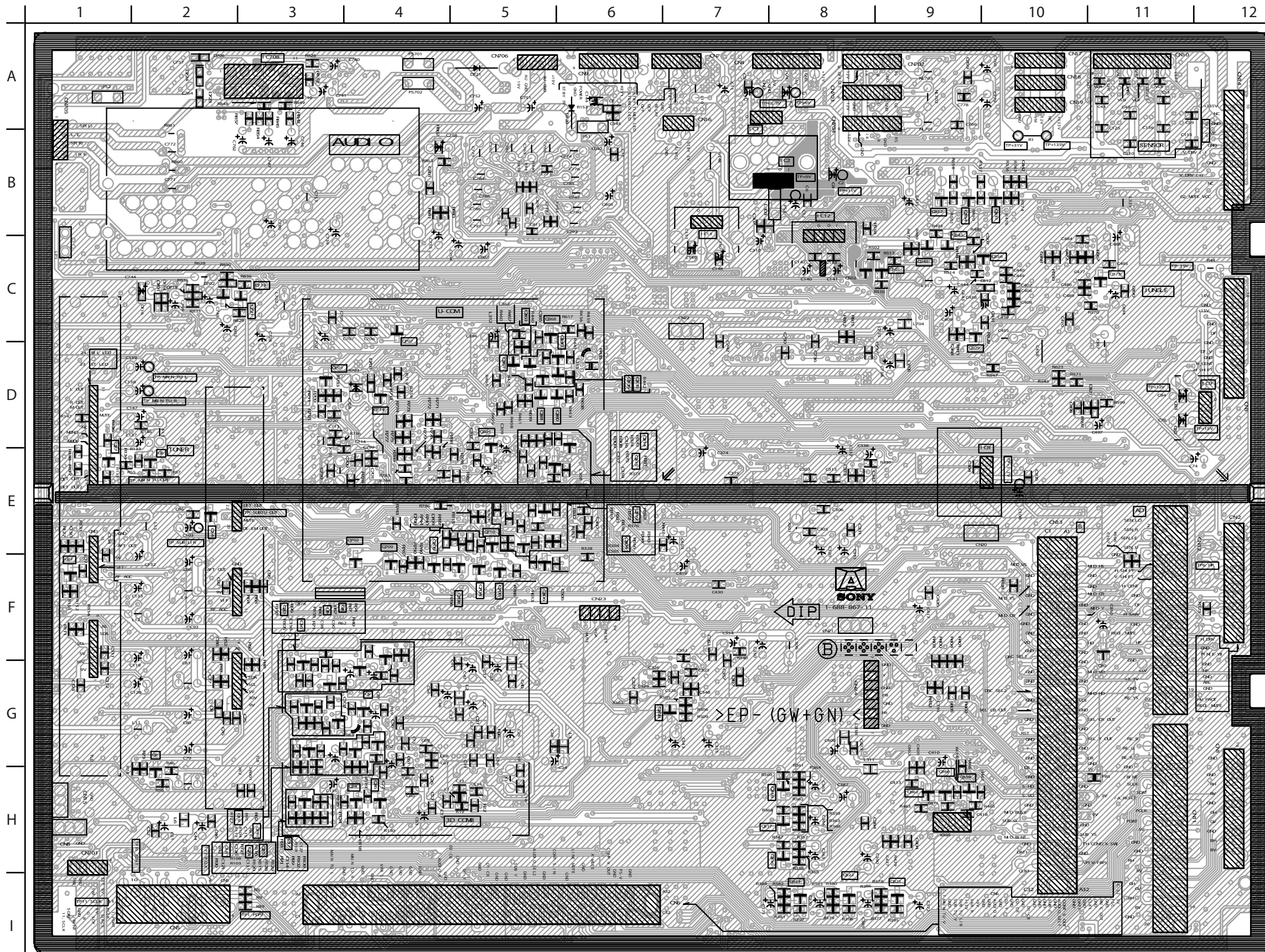

A BOARD LOCATOR LIST

DIODE		TRANSISTOR	
D5	G-2	Q314	E-5
D7	A-6	Q315	E-5
D307	G-7	Q316	H-7
D312	C-9	Q317	H-7
D321	D-10	Q318	H-7
D702	C-2	Q319	E-6
D703	D-4	Q321	I-9
D706	A-2	Q322	I-9
D708	E-4	Q323	I-8
D709	E-4	Q331	B-9
D719	C-2	Q335	D-5
D720	B-6	Q336	D-5
D721	A-5	Q340	C-5
D723	A-2	Q345	B-9
D724	A-2	Q348	C-9
TRANSISTOR		Q354	B-9
Q2	G-2	Q356	B-10
Q4	F-3	Q357	B-9
Q5	G-4	Q358	G-6
Q6	F-3	Q361	C-5
Q8	E-2	Q363	C-5
Q14	E-2	Q368	C-5
Q15	F-3	Q373	C-11
Q16	F-3	Q380	D-5
Q17	H-3	Q381	D-5
Q18	F-3	Q501	C-9
Q19	F-3	Q502	C-8
Q20	F-3	Q701	D-3
Q22	F-1	Q702	E-3
Q23	G-4	Q704	F-5
Q24	H-4	Q705	F-5
Q25	G-4	Q706	F-5
Q26	H-4	Q707	C-4
Q27	D-11	Q708	F-4
Q28	G-4	Q709	E-4
Q30	F-11	Q710	E-5
Q301	D-5	Q713	C-3
Q304	E-6	Q714	D-4
Q306	F-5	Q721	C-3
Q309	C-9		

AD [DIGITAL REGI, PJED CPU, PJE DRIVE]
COMPONENT SIDE

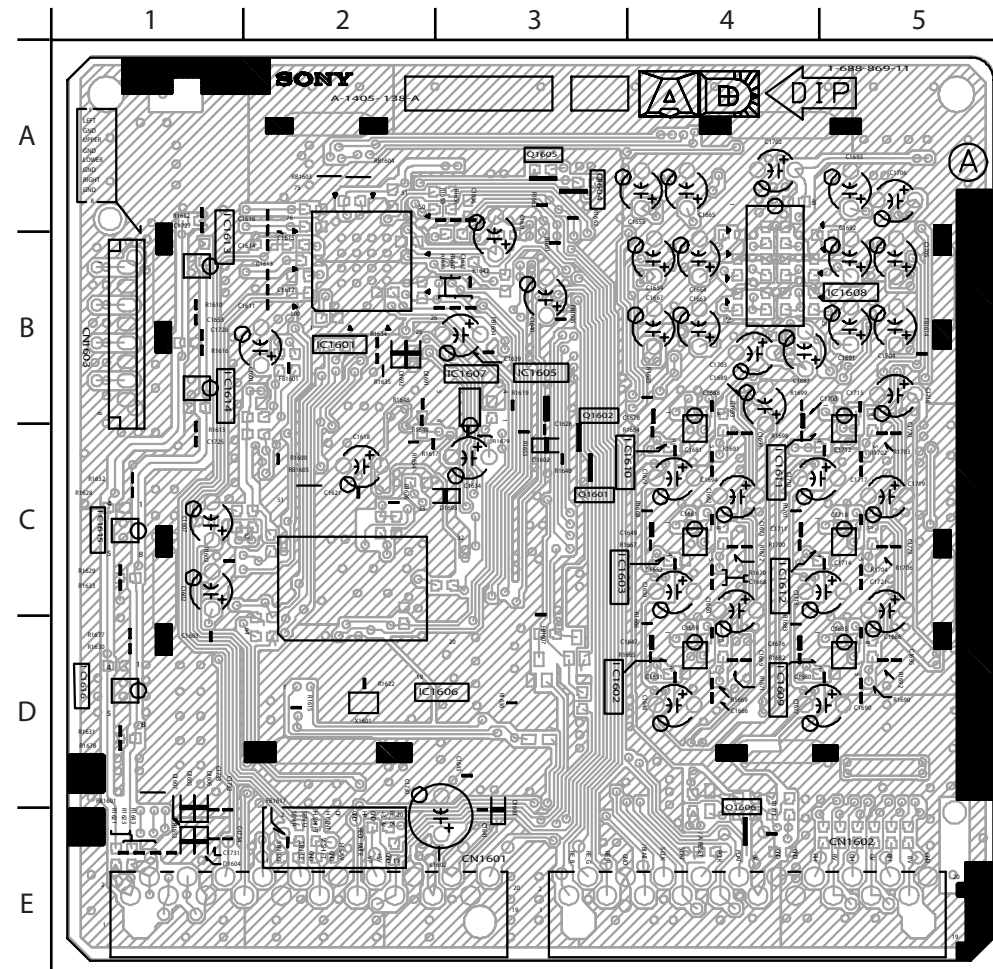

AD [DIGITAL REGI, PJED CPU, PJE DRIVE]
CONDUCTOR SIDE

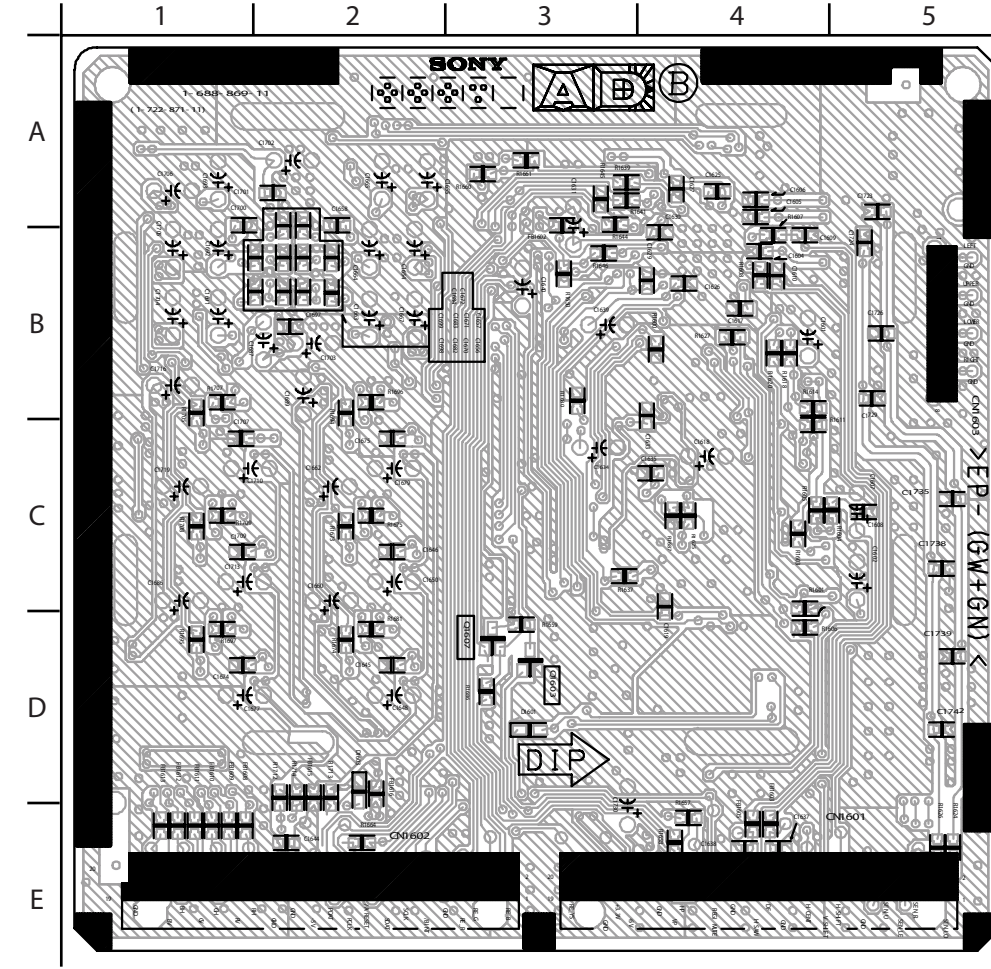

U BOARD SCHEMATIC DIAGRAM

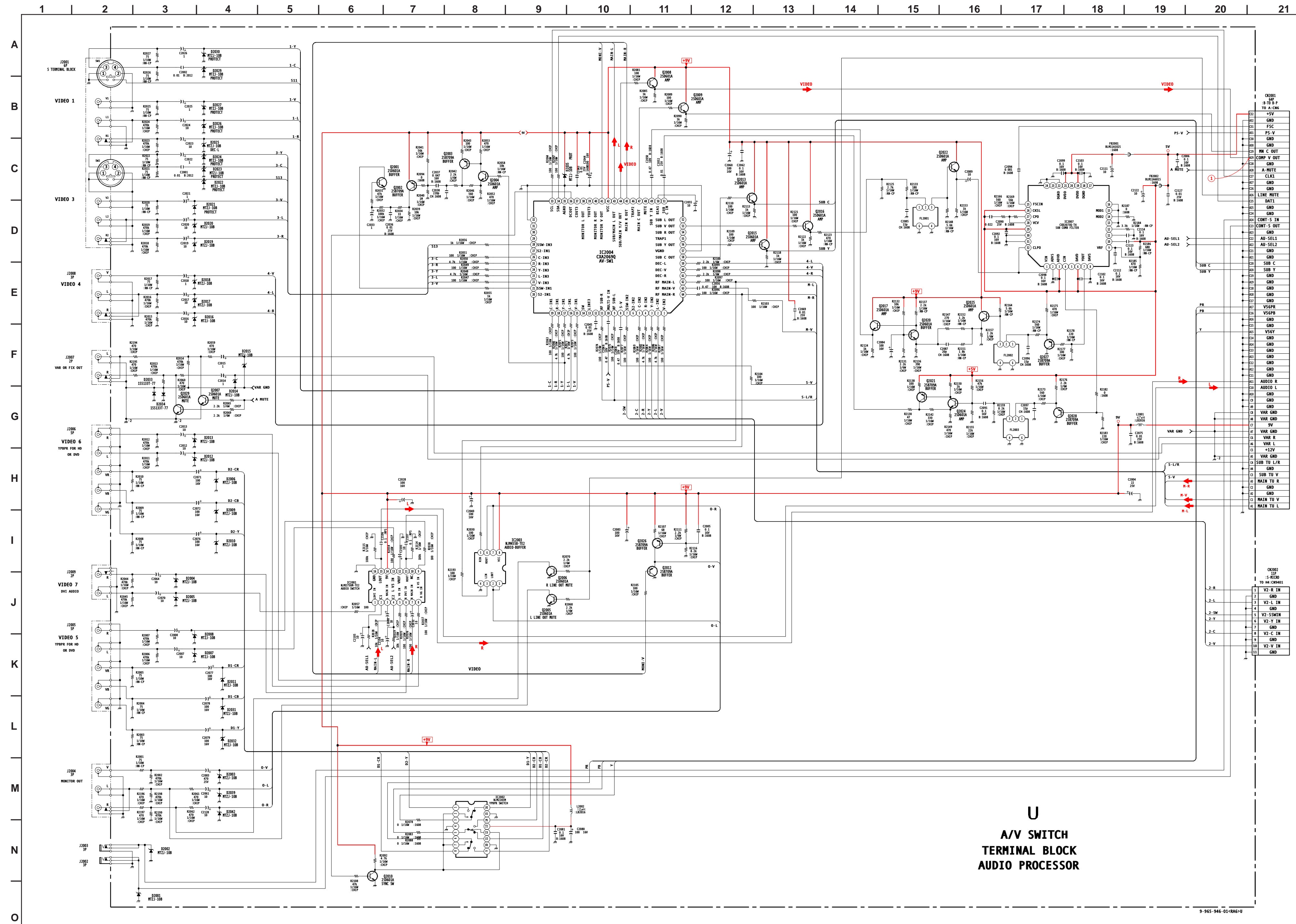

U
A/V SWITCH
TERMINAL BLOCK
AUDIO PROCESSOR

U BOARD WAVEFORMS

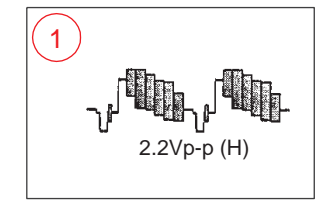

U BOARD IC VOLTAGE LIST

IC2001		IC2004		45	4.5	19	5.0
PIN	VOLT	PIN	VOLT				
1	4.5	1	3.9	47	4.4	21	5.0
2	0.0	2	4.4	48	NC	22	GND
3	4.5	3	3.9	49	5.3	23	NC
4	0.0	4	4.4	50	4.5	24	GND
5	4.5	5	0.5	51	4.4	25	2.5
6	4.5	6	NC	52	4.5	26	5.0
7	4.5	7	4.9	53	4.9	27	2.2
8	4.5	8	4.5	54	4.5	28	2.2
9	9.0	9	4.4	55	NC	29	5.0
10	4.5	10	4.3	56	4.5	30	GND
11	4.5	11	4.4	57	GND	31	GND
12	4.5	12	4.4	58	4.3	32	1.8
13	4.5	13	NC	59	4.4		
14	4.5	14	NC	60	3.9		
15	4.5	15	3.9	61	4.4		
16	GND	16	4.4	62	4.4		
IC2002		17	3.9	63	4.3		
IC2003		18	4.4	64	4.5		
IC2007							
1	4.6	19	4.4				
2	5.0	20	NC	PIN	VOLT		
3	3.1	21	4.9	1	1.8		
4	GND	22	3.9	2	GND		
5	3.1	23	3.9	3	5.0		
6	3.1	24	4.4	4	1.1		
7	5.0	25	3.9	5	NC		
8	4.6	26	4.4	6	5.0		
9	4.6	27	NC	7	1.3		
10	GND	28	0.1	8	GND		
11	4.6	29	NC	9	2.0		
12	5.0	30	NC	10	2.7		
13	9.0	31	NC	11	1.0		
14	4.6	32	GND	12	2.0		
15	GND	33	4.4	13	GND		
16	4.6	34	4.4	14	0.0		
IC2003		35	GND	15	GND		
IC2007		36	0.0	16	GND		
IC2003		37	NC	17	NC		
1	4.5	38	4.5	18	GND		
2	4.5	38	NC	17	NC		
3	4.4	39	NC				
4	GND	40	4.5				
5	4.4	41	4.4				
6	4.5	42	9.0				
7	4.5	43	4.4				
8	9.0	44	4.3				

All voltages are in V.

U BOARD TRANSISTOR LIST

	B	C	E
Q2001	0.1	4.9	GND
Q2002	8.4	0.1	9.0
Q2003	7.8	5.6	8.5
Q2004	3.8	7.8	3.2
Q2005	0.3	0.0	GND
Q2006	0.3	0.0	GND
Q2007	0.4	0.0	0.0
Q2008	4.3	9.0	3.7
Q2009	4.4	9.0	3.7
Q2010	0.0	5.0	GND
Q2012	4.5	GND	5.1
Q2013	4.3	9.0	3.7
Q2015	4.5	9.0	3.9
Q2016	4.7	9.0	8.7
Q2017	5.0	9.0	4.4
Q2020	1.6	5.0	1.0
Q2021	4.2	1.3	4.8
Q2022	3.3	9.0	2.7
Q2024	1.5	4.2	0.9
Q2025	2.6	9.0	2.0
Q2026	7.2	5.1	7.9
Q2027	1.3	GND	2.0
Q2028	1.1	GND	1.7
Q2029	0.4	0.0	GND

All voltages are in V.



[AV SWITCH, TERMINAL BLOCK, AUDIO PROCESSOR]

CONDUCTOR SIDE

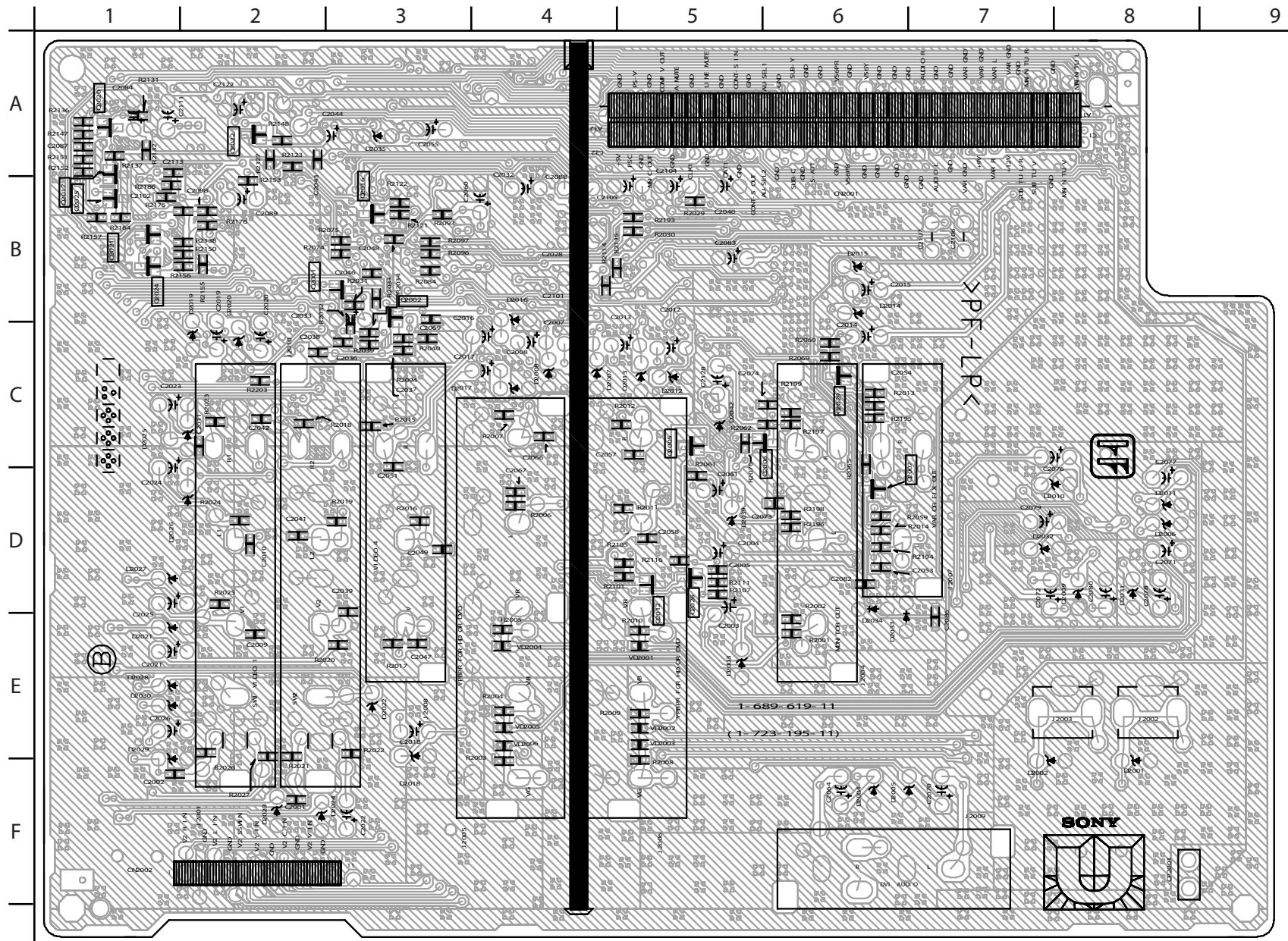

B BOARD SCHEMATIC DIAGRAM (2 OF 2)

Due to the complexity of this board, performing component level repairs is not recommended. If service is required, complete board replacement is the preferred repair method. Data is provided for reference only.

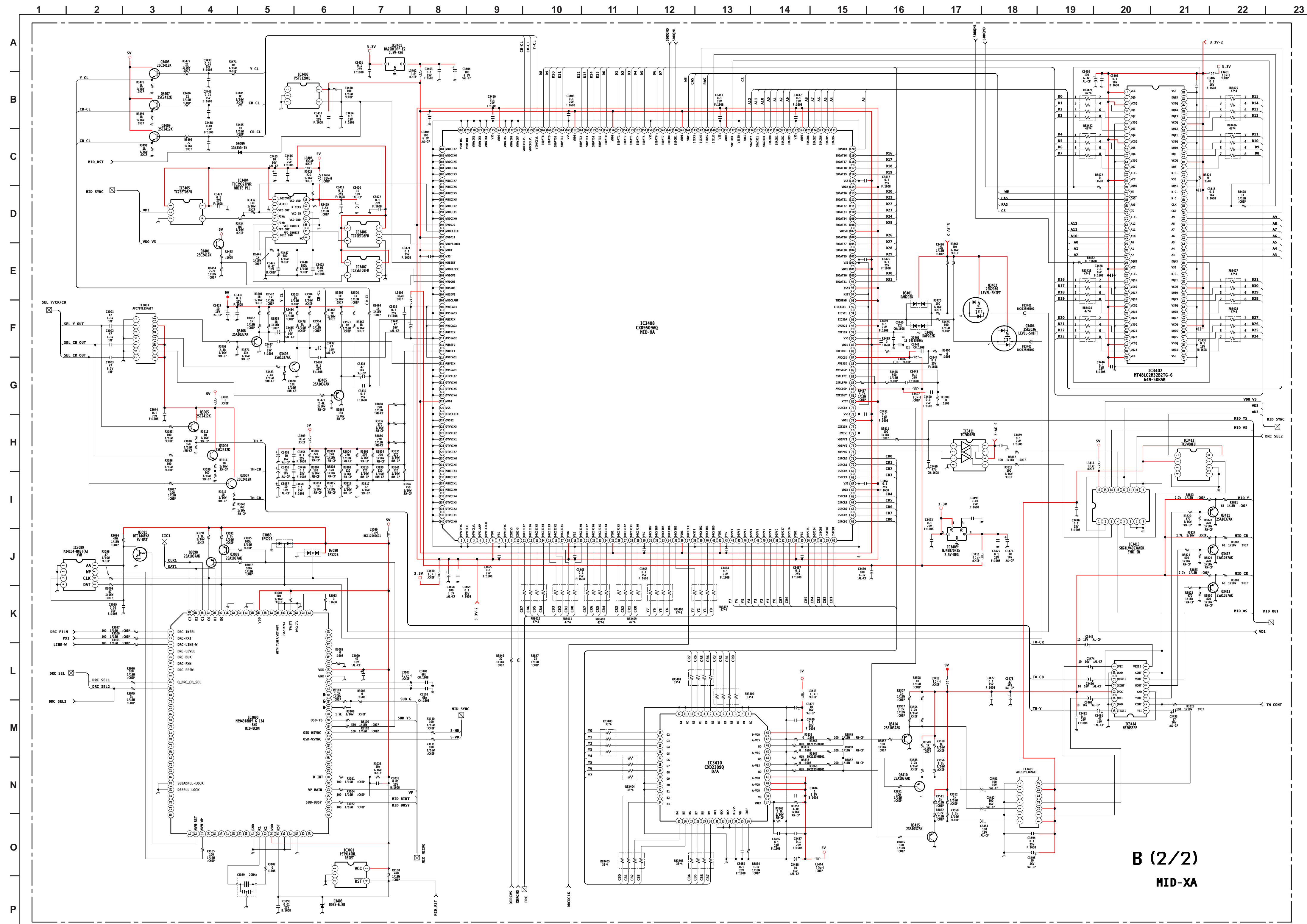

B [AD-DRC, MID-XA]
COMPONENT SIDE

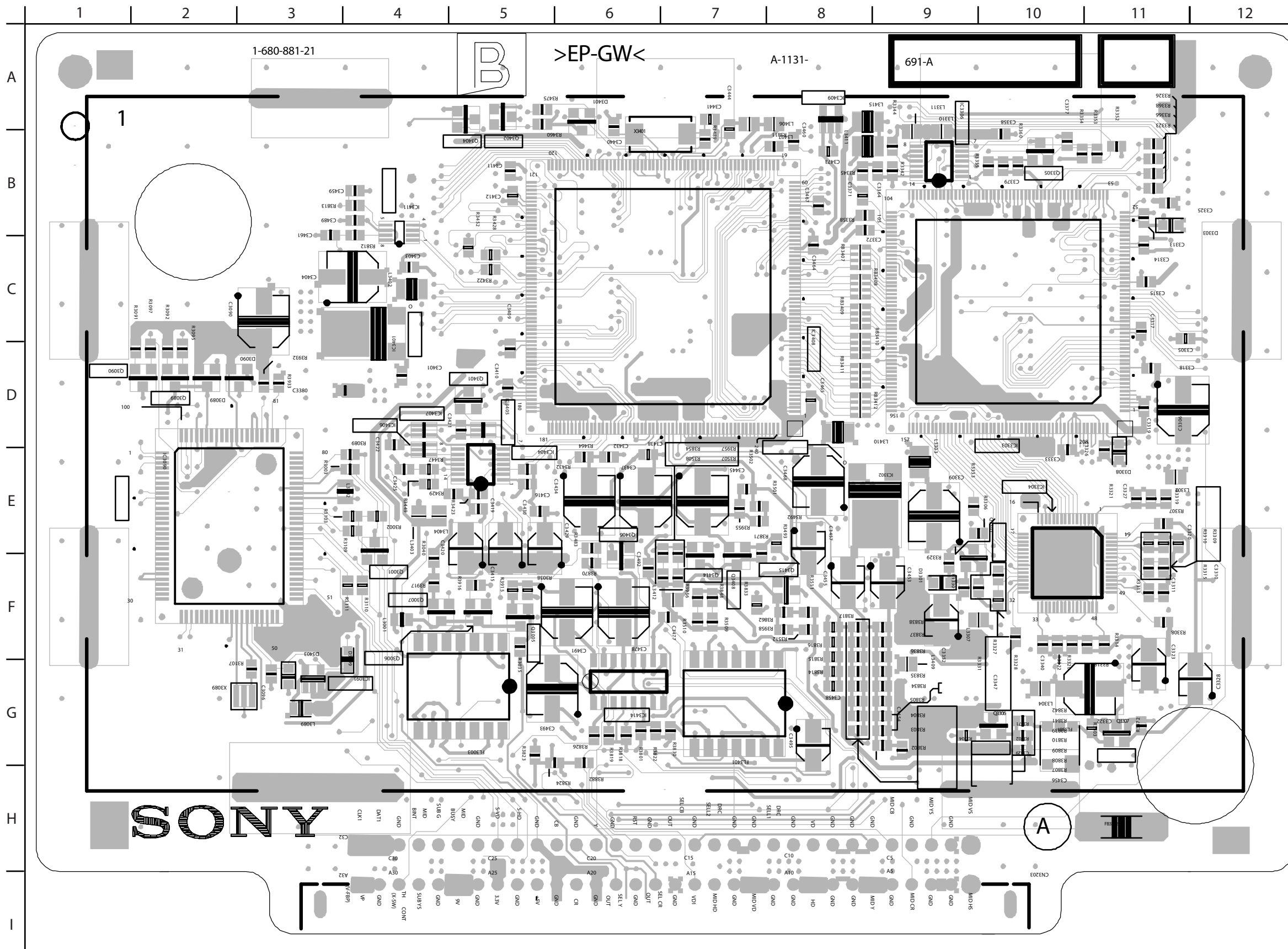

D BOARD SCHEMATIC DIAGRAM

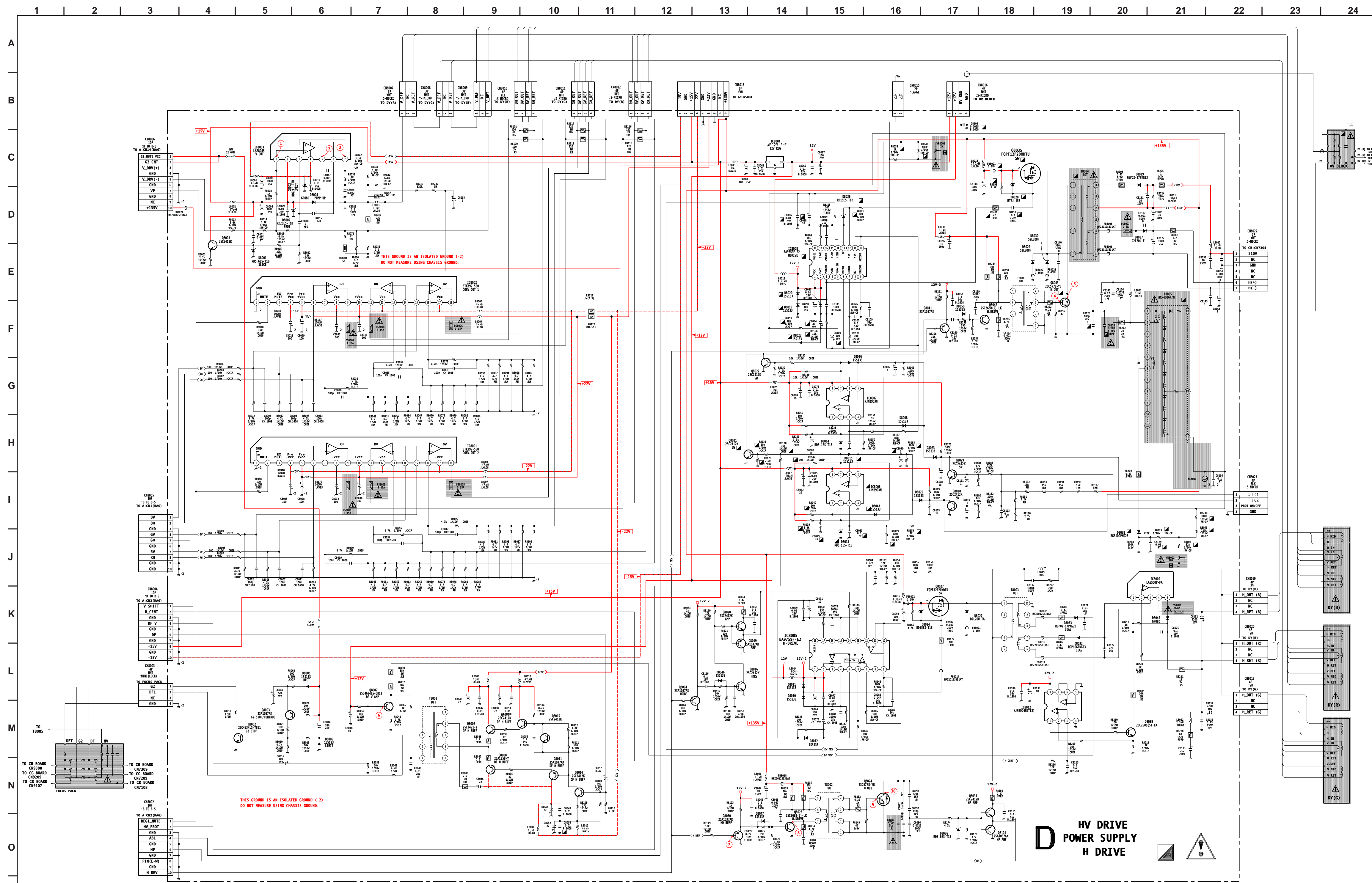

D BOARD WAVEFORMS

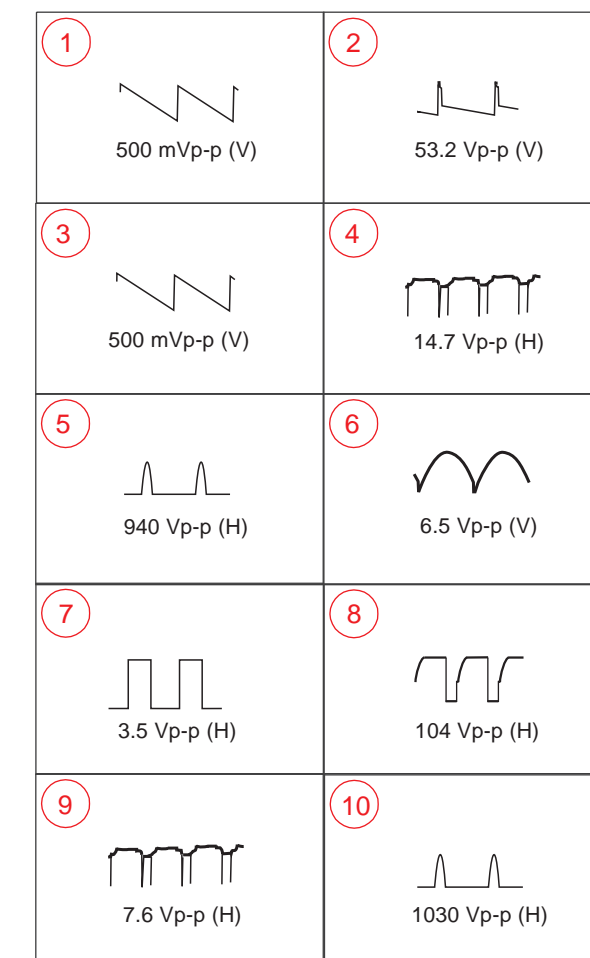

D BOARD IC VOLTAGE LIST

IC8001	14	0.3	15	GND	10	7.4	
PIN	VOLT	15	0	16	3.2	11	7.4
1	GND	16	0	17	2.6	12	7.4
2	4.3	17	-22	18	9.1	13	GND
3	N/C	18	0.1	IC8006		14	7.1
4	-22.0	IC8003		PIN	VOLT	15	GND
5	22.0	PIN	VOLT	1	0.1	16	3.2
6	-0.3	1	1.3	2	5.0	17	2.6
7	-0.3	2	15.0	3	4.5	18	9.1
8	-22.0	3	-13.1	4	GND	IC8009	
9	-0.5	4	-15.0	5	0.0	PIN	VOLT
10	22.0	5	0.4	6	5.0	1	98.2
11	0.1	6	15.0	7	0.1	2	98.2
12	-22.0	7	1.3	8	15.0	3	94.0
13	0.0	IC8004		IC8007		4	97.8
14	0.0	PIN	VOLT	PIN	VOLT	5	101.1
15	0.0	I	15.0	1	0.1	IC8010	
16	0.0	O	12.0	2	5.0	PIN	VOLT
17	-22.0	G	GND	3	4.0	I	7.0
18	0.1	IC8005		4	GND	O	5.0
IC8002		PIN	VOLT	5	0.0	G	GND
PIN	VOLT	1	12.0	6	5.0	IC8012	
1	GND	2	12.0	7	0.1	PIN	VOLT
2	4.3	3	5.8	8	15.0	1	2.7
3	N/C	4	GND	IC8008		2	2.1
4	-22.0	5	3.8	PIN	VOLT	3	2.1
5	22.0	6	3.8	1	12.0	4	GND
6	-0.1	7	3.8	2	12.0	5	GND
7	-0.1	8	N/C	3	6.0	6	0.0
8	-22.0	9	3.8	4	GND	7	0.0
9	0.0	10	3.6	5	8.0	8	12.0
10	22.0	11	3.6	6	7.4		
11	0.5	12	3.6	7	7.4		
12	-22.0	13	GND	8	N/C		
13	0.3	14	7.1	9	3.3		

D BOARD TRANSISTOR LIST

Q8001	-0.4	15.0	0.1	Q8022	0.0	8.9	GND
Q8002	0	13.0	GND	Q8023	-0.5	68.0	GND
Q8003	14.6	0.0	14.6	Q8024	0.1	242.0	GND
Q8004	3.4	GND	4.0	Q8028	0.5	0.0	GND
Q8005	3.4	GND	4.1	Q8029	0.5	0.0	GND
Q8007	5.8	204.0	5.2	Q8030	3.4	GND	4.0
Q8008	2.8	-22.0	3.3	Q8031	0.2	12.0	0.6
Q8009	4.0	22.0	3.4	Q8032	3.4	4.1	GND
Q8010	4.5	22.0	4.0	Q8036	8.9	GND	8.7
Q8011	2.3	-22.0	2.7	Q8037	8.9	14.6	8.7
Q8014	-20.0	2.3	-20.6	Q8039	2.7	76.7	2.1
Q8015	2.9	4.5	2.3	Q8041	3.4	GND	8.9
Q8016	-0.3	7.4	GND	Q8042	9.6	29.8	GND
Q8019	7.4	GND	7.2	Q8043	8.9	192.0	0.1
Q8020	7.4	12.0	7.2	Q8044	0.6	0.0	GND
Q8021	0.0	8.9	GND	Q8101	0.2	GND	0.6
				Q8038	8.9	192.0	0.6

D HV DRIVE POWER SUPPLY H DRIVE



9-965-946-02-046-0

D

[HV DRIVE, POWER SUPPLY, H DRIVE]
COMPONENT SIDE

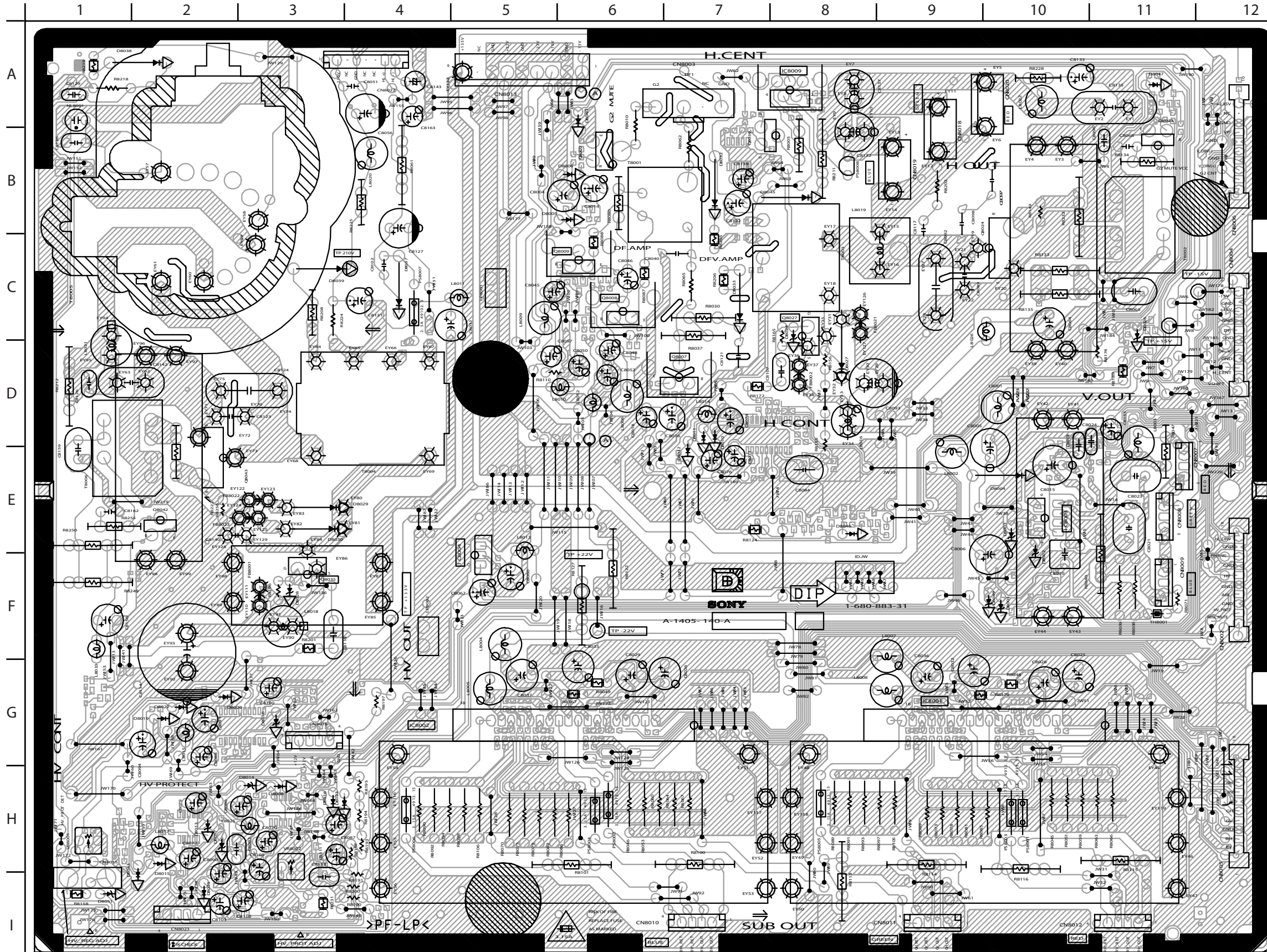

D [HV DRIVE, POWER SUPPLY, H DRIVE]
CONDUCTOR SIDE

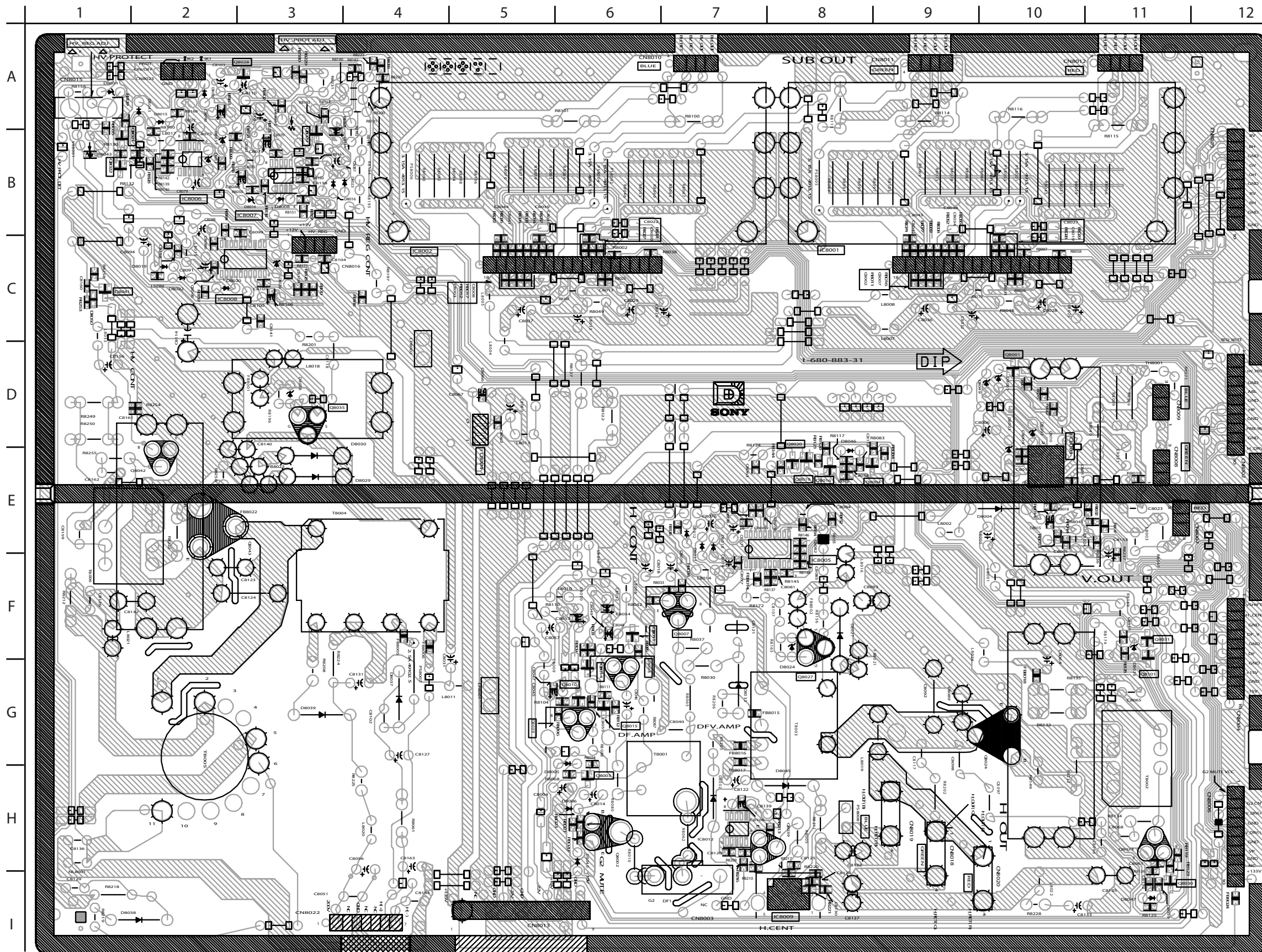

D BOARD LOCATOR LIST

DIODE		IC	
D8001	D-10	IC8001	C-8
D8002	D-10	IC8002	C-4
D8003	D-10	IC8003	E-10
D8004	E-10	IC8004	E-5
D8005	H-6	IC8005	F-8
D8006	H-6	IC8006	B-2
D8007	D-10	IC8007	B-3
D8008	B-3	IC8008	C-2
D8009	C-1	IC8009	I-8
D8010	E-11	IC8012	H-7
D8011	E-11	TRANSISTOR	
D8012	E-11	Q8001	D-10
D8013	B-2	Q8002	H-6
D8014	B-3	Q8003	H-6
D8015	A-2	Q8004	E-9
D8016	B-3	Q8005	C-1
D8019	C-2	Q8007	F-7
D8020	C-2	Q8008	G-6
D8021	F-9	Q8009	G-5
D8022	C-2	Q8010	G-6
D8023	B-3	Q8011	F-6
D8024	G-7	Q8014	G-6
D8025	A-2	Q8015	G-6
D8026	G-11	Q8016	E-8
D8027	F-8	Q8019	E-8
D8028	D-3	Q8020	D-8
D8029	E-4	Q8021	B-1
D8030	E-4	Q8022	B-1
D8031	D-2	Q8023	H-11
D8032	H-7	Q8024	G-10
D8033	G-7	Q8027	F-8
D8034	E-2	Q8028	A-2
D8035	E-2	Q8029	B-3
D8036	C-3	Q8030	I-11
D8037	G-4	Q8031	F-11
D8038	I-2	Q8032	C-1
D8039	G-4	Q8035	D-3
D8043	B-1	Q8036	D-1
D8045	H-8	Q8037	D-1
D8046	D-8	Q8038	D-1
D8047	I-11	Q8039	H-8
		Q8101	G-11

SR BOARD SCHEMATIC DIAGRAM

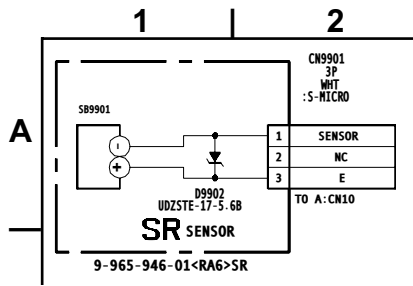

H2 BOARD SCHEMATIC DIAGRAM

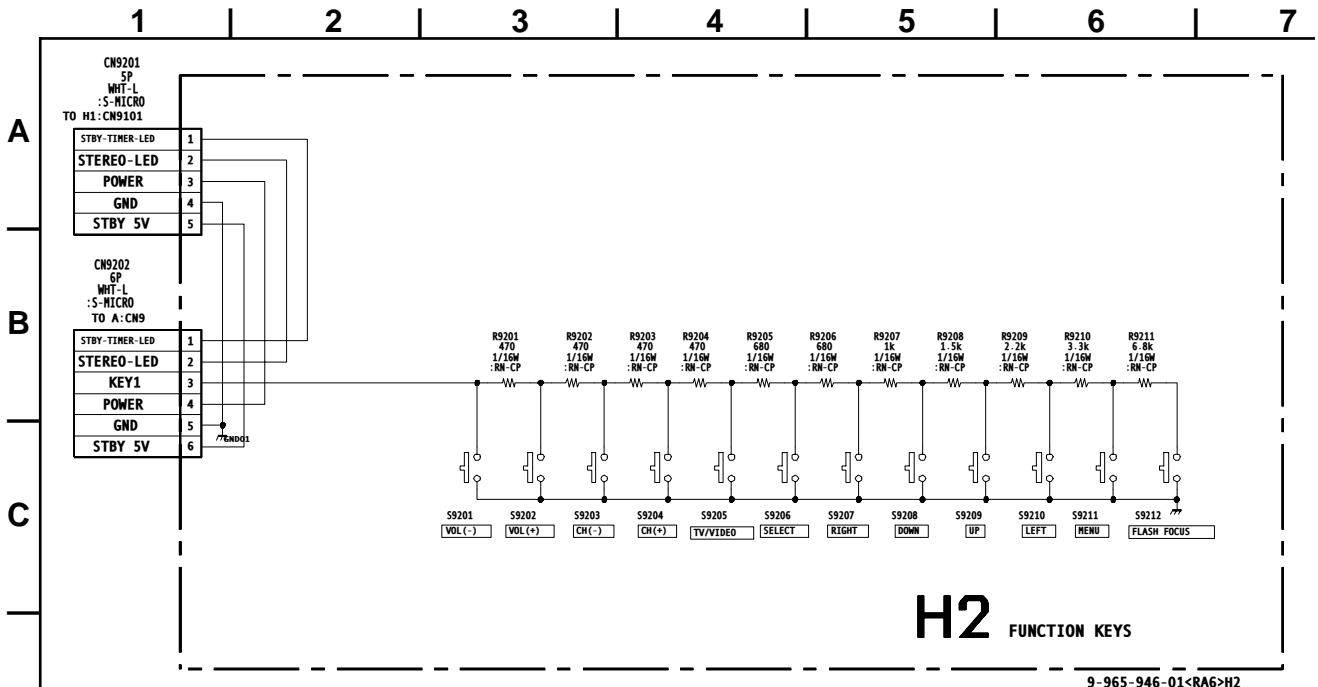

H1 BOARD SCHEMATIC DIAGRAM

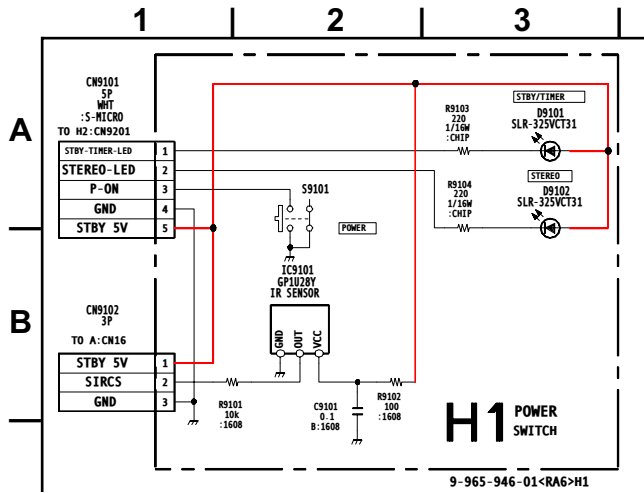

H1 [POWER SWITCH]
COMPONENT SIDE

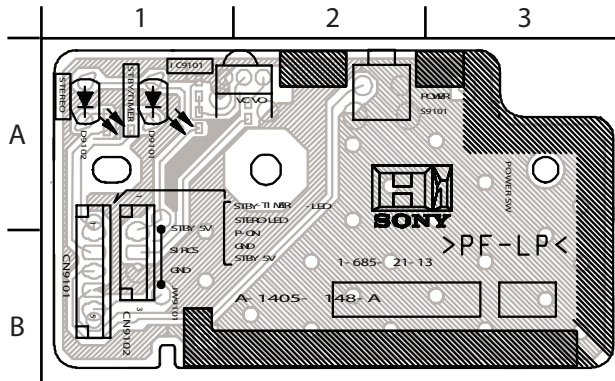

H1 [POWER SWITCH]
CONDUCTOR SIDE

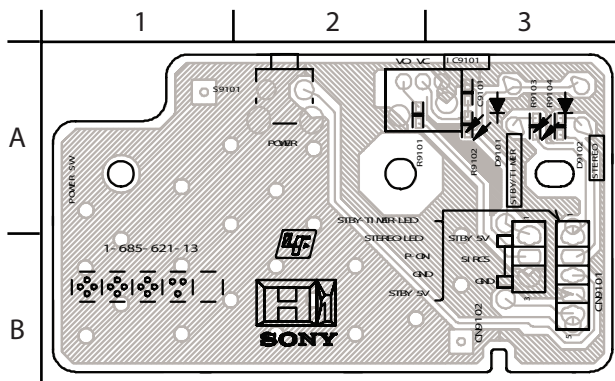

H4 BOARD SCHEMATIC DIAGRAM

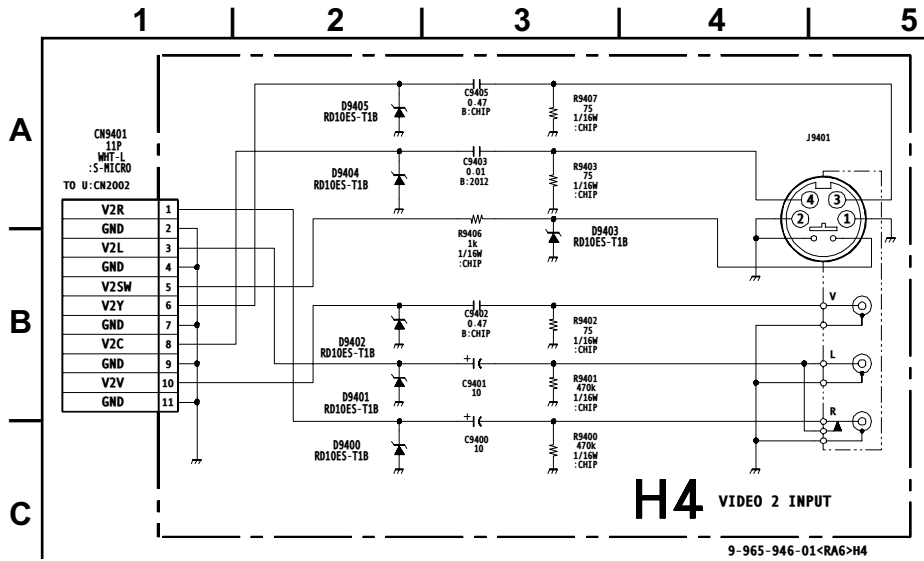

H4 [VIDEO 2 INPUT] COMPONENT SIDE

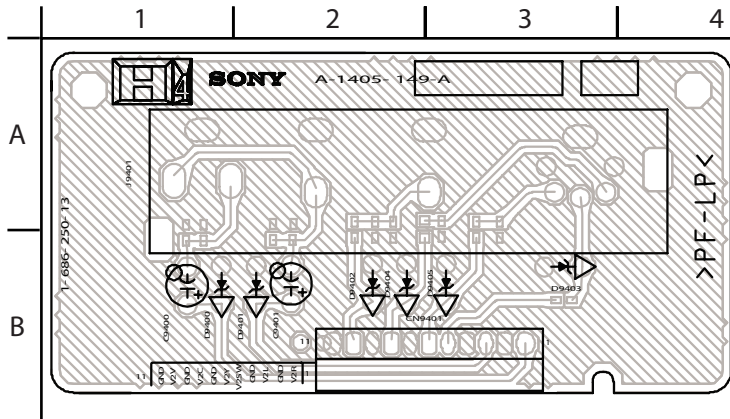

H4 [VIDEO 2 INPUT] CONDUCTOR SIDE

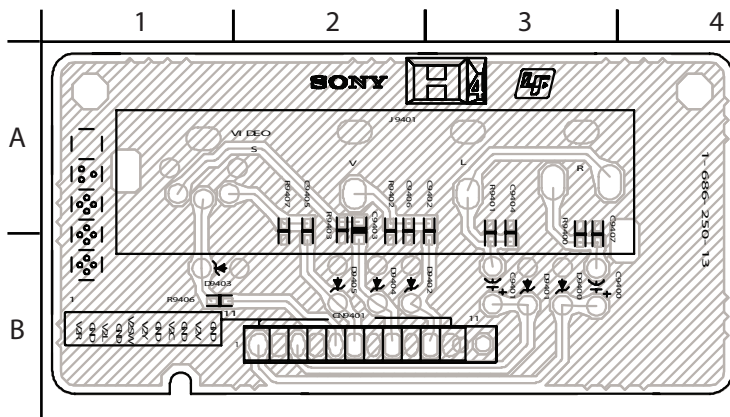

5-5. IC BLOCK DIAGRAMS

A BOARD

IC305, 307 SN74LV4053ANSR

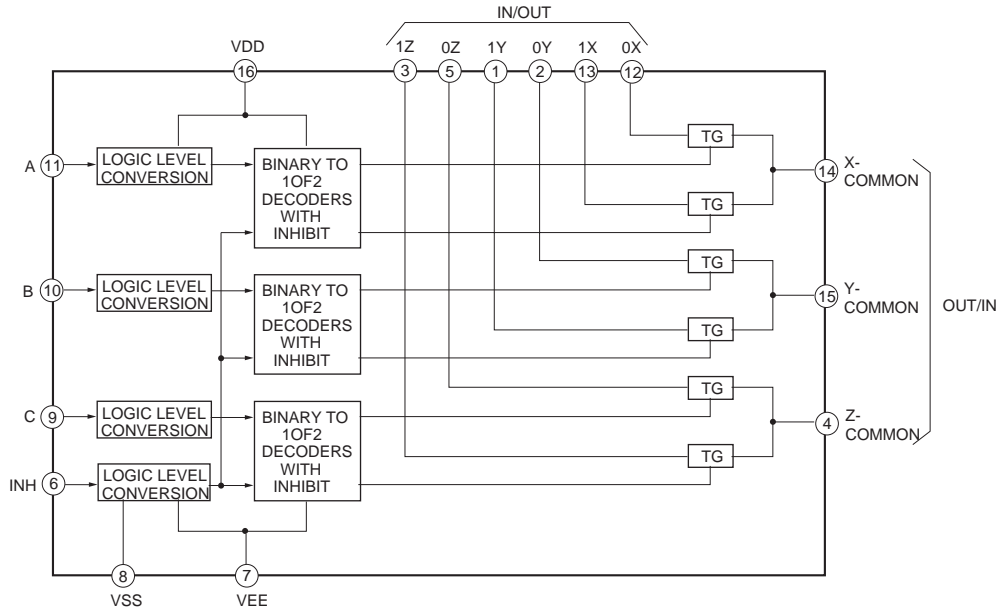

IC305, TDA7265

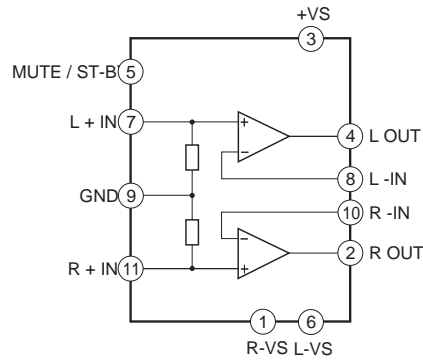

B BOARD
IC3305, 3404 TLC2932IPWR

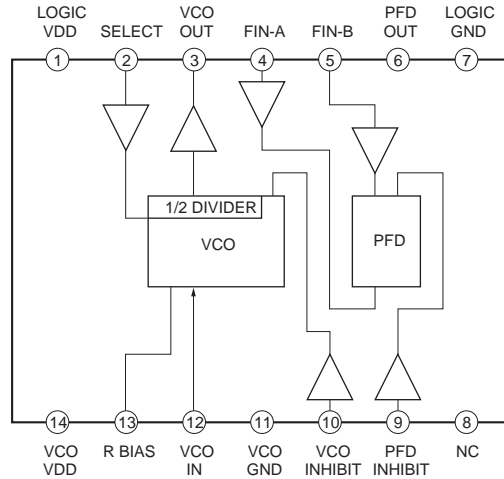

IC3413 SN74LV4053ANSR

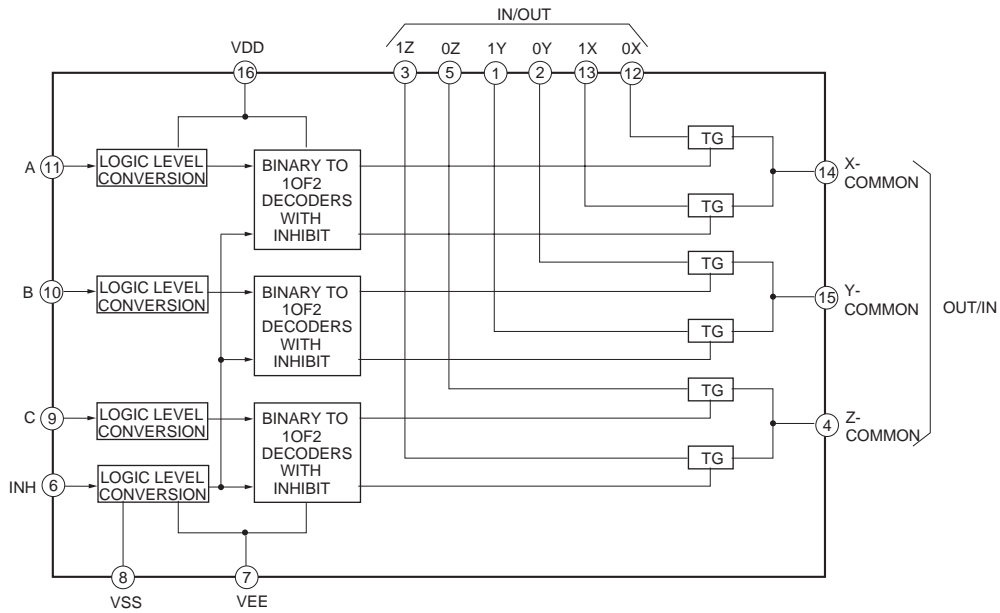

IC3414 M52055P

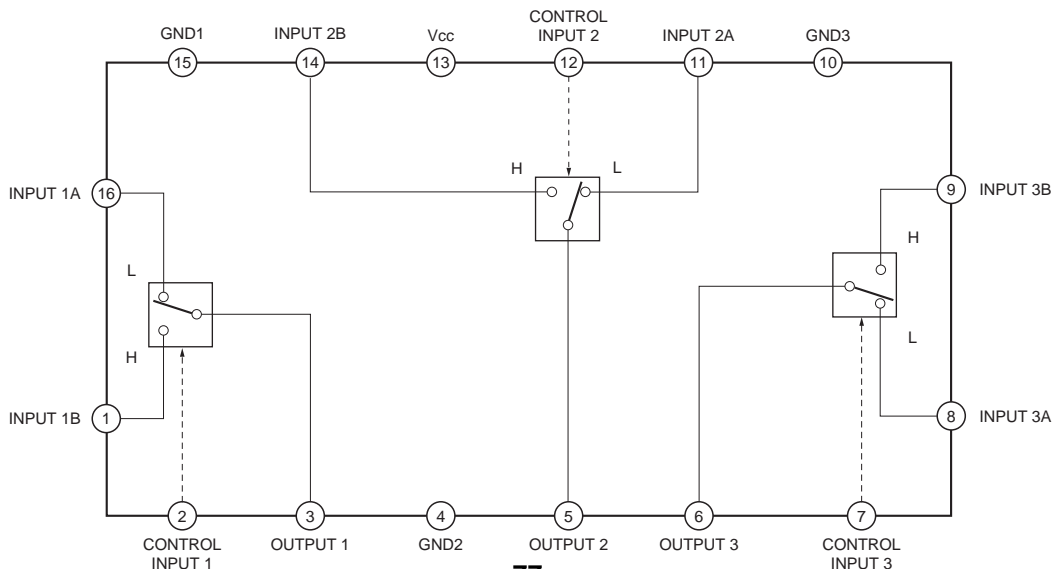

CR BOARD
IC7101 TDA6120Q

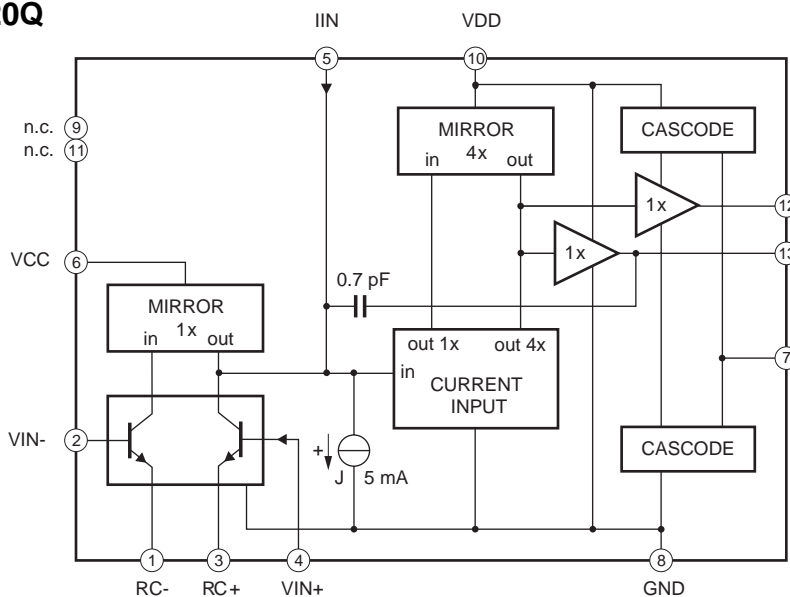

CG BOARD
IC7201 TDA6120Q

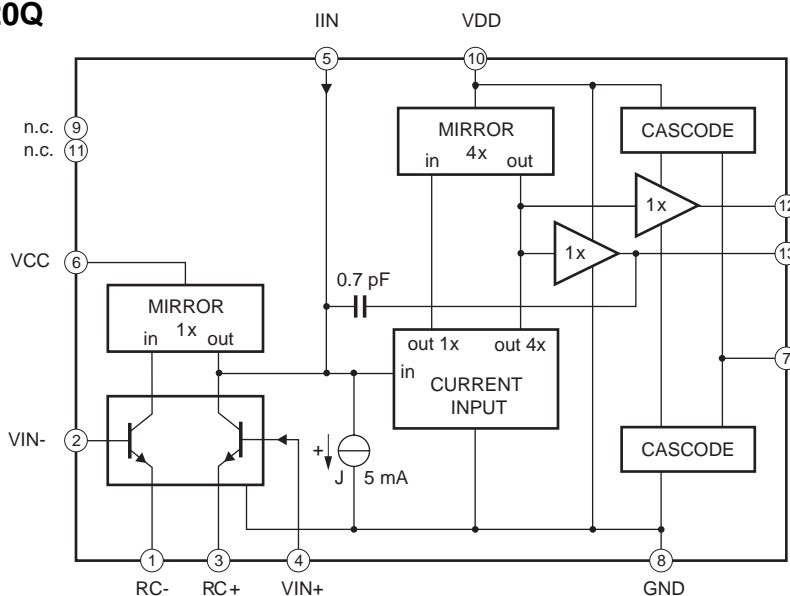

CB BOARD
IC7301 TDA6120Q

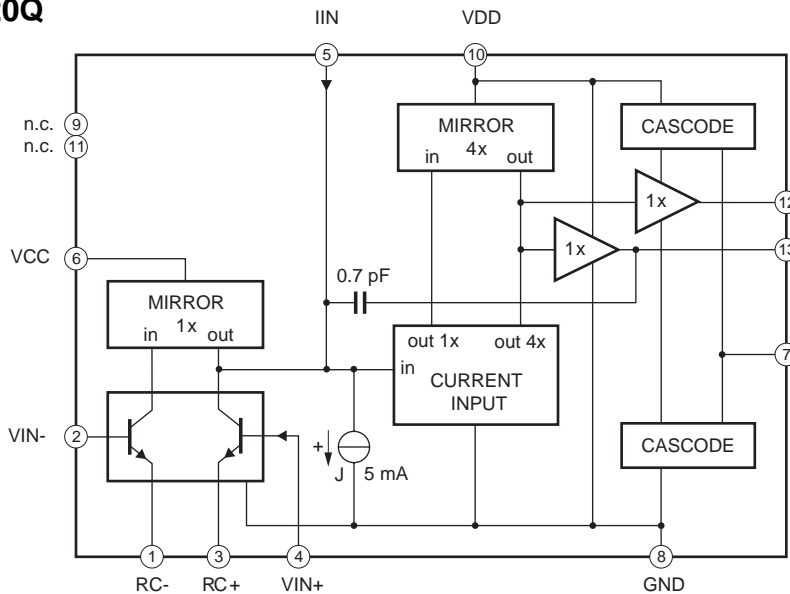

U BOARD
IC2004 CXA2069Q

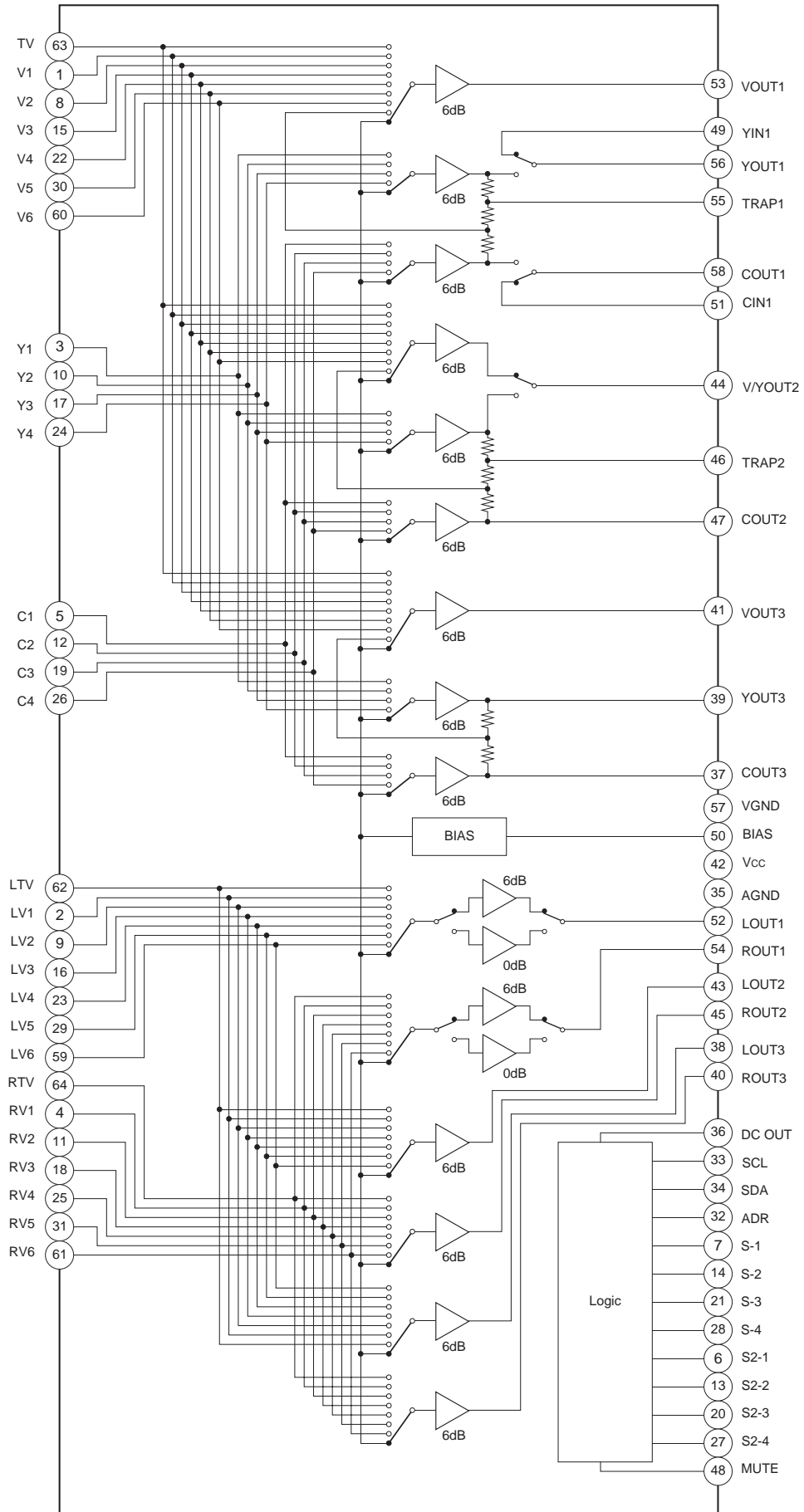

5-6. SEMICONDUCTORS

1SS83TD
21DP05
D1NL40-TR2
D1NS4
D2L20U
EL1Z
GP08DPKG23
RD10ES-B2
RD15ES-B2
RD18ES-B2
RD20ES-B2
RD5.6ES-B2
RGP02-17EL-6433
UF4005PKG23

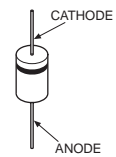

1SS133T-77
30DF4N-FC5
ERC04-06SE
ERC91-02

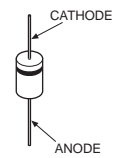

1SS226

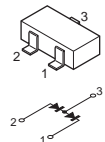

1S355TE-17
DTZ-10B
DTZ-TT11-6.8B
UDZS-TE-17-7.5B
UDZ-TE-17-10B
UDZS-TE-17-18B
UDZS-TE-17-22B
UDZS-TE-17-24B
UDZS-TE-17-3.9B
UDZS-TE-17-33B
UDZS-TE-17-4.7B
UDZS-TE-17-5.1B
UDZS-TE-17-5.6B
UDZS-TE-17-6.2B
UDZS-TE-17-9.1B

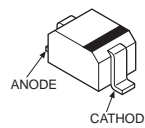

D1NL20U-TR

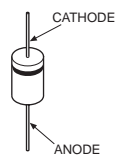

D4SBS4-F
D6SB60L

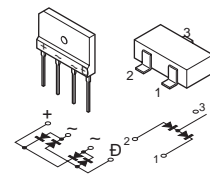

DAN202K-T-146

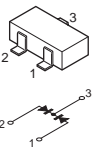

DAN202U

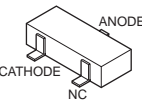

DAP202K

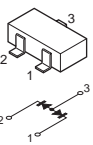

MTZJ-T-77-13
MTZJ-T-77-22B

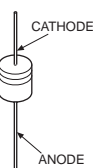

SLR-325VCT31

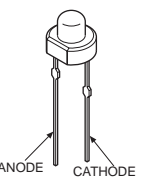

BA033T
NJM7812FA
TA7812S

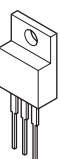

BA05T

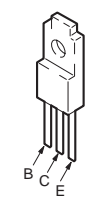

BA9759F-E2

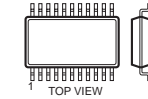

18pin SOP

CD0031AM

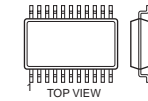

48pin SOP

CM0017AF

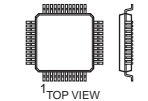

120pin QFP

CXA2151Q
CXD2013Q-T6

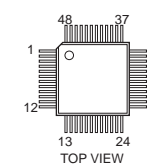

CXD2073Q-T4

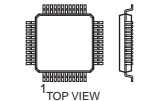

32pin QFP

NJM2750
PCM56P-L
SN74LV4053ANSR

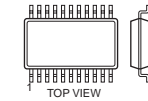

16pin SOP

CXA1726AM
NJM2180M

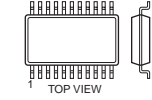

30pin SOP

CXA2069Q
CXP85840A-039Q
CXP86448-635Q
CX2150AQ

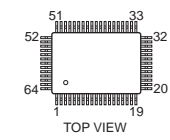

DM-58

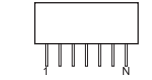

MARKING SIDE VIEW

ψpin 1 ~ N
ψMt (one side, both side)

14pin DIP

LA78045

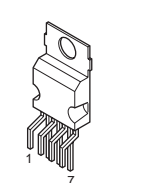

M24C08-MN6T
M24C32-WMN6T
NJM2068V
NJM2904M
UPC4558G2

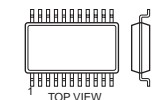

8pin SOP

M306V2ME-175FP
UPD64083GF-3BA

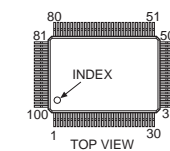

MSM514265C-60JS

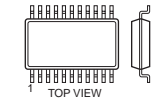

40pin SOP

NJM2395AF05
PQ09RF21

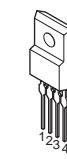

NJM2903M
UPC393C



8pin DIP

NJM7905FA

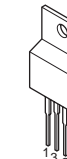

NJW1148

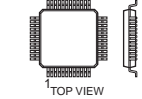

48pin QFP

PQ1CG2032FZ

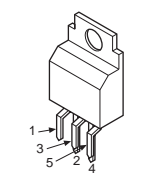

PST9143NL
PST9145NL

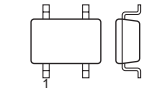

5pin CHIP

STK392-560

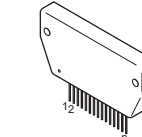

MARKING SIDE VIEW

TC7W08FU(TE12R)

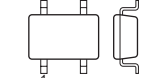

8pin CHIP

TDA6120Q / N2/S2

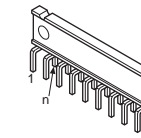

TDA7265

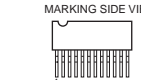

11pin ZIP

TLC2933IPWR

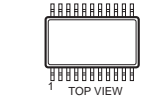

14pin SOP

UPC1093J-1-T

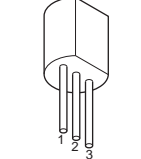

2SA1358-Y
2SA3421-Y

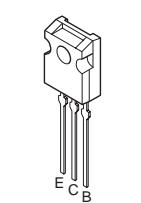

2SA1037AK-T14
2SA1226-T1E3E
2SC1623-L516
2SD601A-QRS-T
DTC114EKA-T14
DTC144EKA-T14

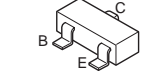

2SA2005
2SC5511

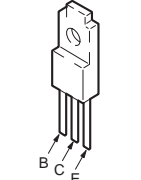

2SC2688-LK
LETTER SIDE

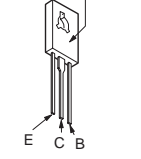

2SC4634LS-CB11

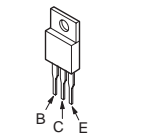

2SK2036(TE85L)

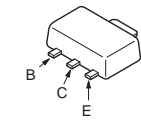

IRFIB7N50A

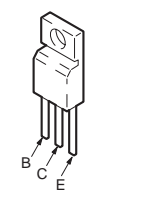



SECTION 6: EXPLODED VIEWS

Components not identified by a part number or description are not stocked because they are seldom required for routine service.

The component parts of an assembly are indicated by the reference numbers in the far right column of the parts list and within the dotted lines of the diagram.

* Items marked with an asterisk are not stocked since they are seldom required for routine service. Expect some delay when ordering these components.

NOTE: The components identified by shading and  mark are critical for safety. Replace only with part number specified.

NOTE: Les composants identifiés par un trame et une marque  sont critiques pour la sécurité. Ne les remplacer que par une pièce portant le numéro spécifié.

6-1. COVER

- 7-685-661-14 SCREW +BVTP 4X12 TYPE2 IT-3
- 7-685-648-79 SCREW +BVTP 3X12 TYPE2 IT-3

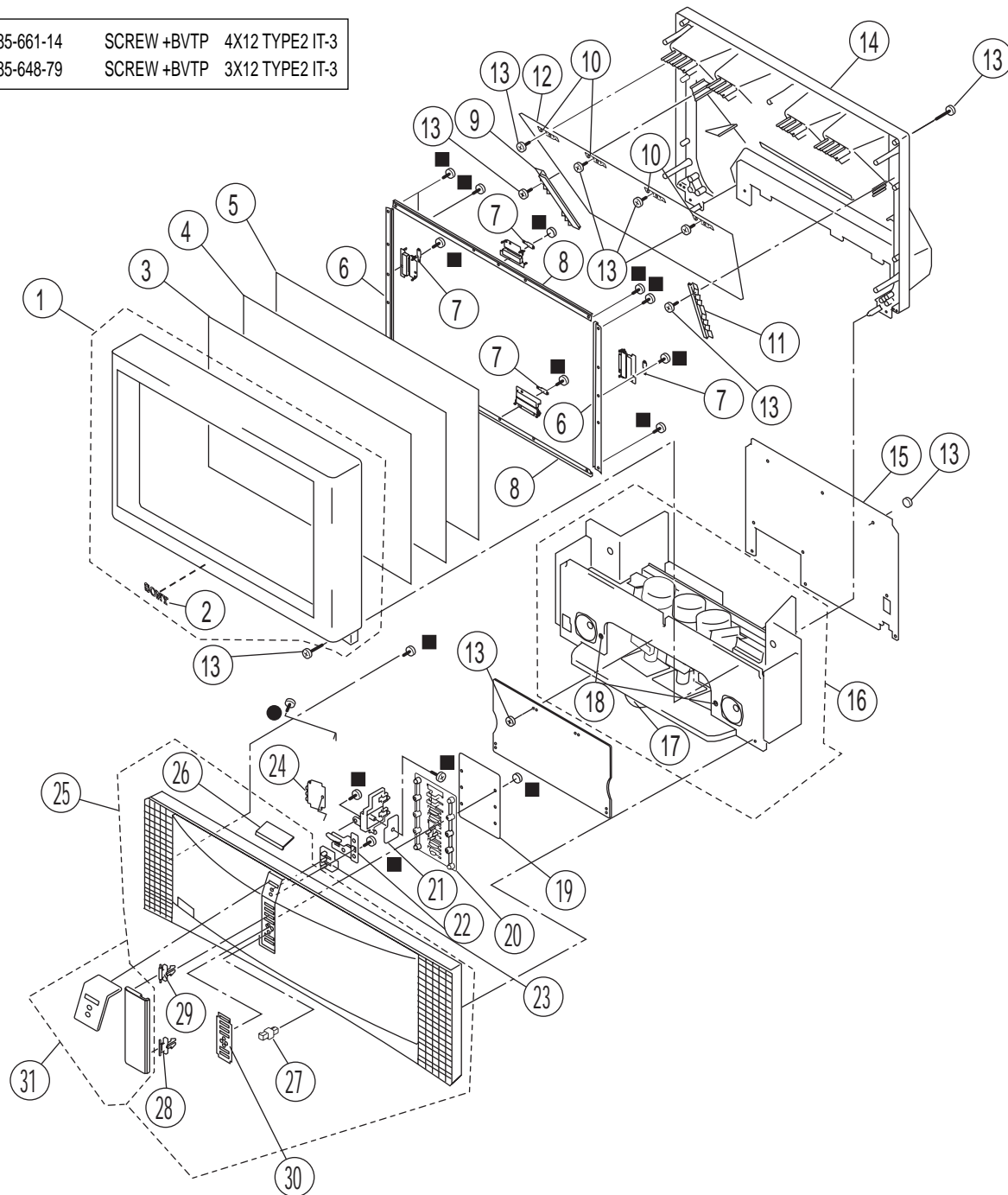

REF.NO.	PART NO.	DESCRIPTION	ASSEMBLY INCLUDES	REF.NO.	PART NO.	DESCRIPTION	ASSEMBLY INCLUDES
1	X-4041-069-2	BEZNET (46) ASSY	(2)	* 16	X-4041-809-1	CABINET ASSY, BOTTOM (46)	(17-18)
2	3-704-179-01	EMBLEM (NO.9), SONY		17	4-084-920-01	FOOT	
3	4-090-943-11	SCREEN (46W), CONTRAST		18	4-084-932-21	CATCH (S)	
4	4-090-944-11	PLATE (46WL), DIFFUSION		* 19	A-1405-147-A	H2 BOARD, MOUNTED	
5	4-090-945-11	PLATE (46WF), DIFFUSION		20	4-082-284-01	BUTTON, MULTI	
				* 21	A-1405-148-A	H1 BOARD, MOUNTED	
* 6	4-084-568-31	HOLDER, SCREEN		22	4-082-283-01	BUTTON, POWER	
* 7	A-1400-759-A	SR BOARD, MOUNTED		23	4-083-733-01	GUIDE (HW), LED	
* 8	4-084-568-21	HOLDER, SCREEN		* 24	A-1405-149-A	H4 BOARD, MOUNTED	
* 9	4-091-245-01	HOLDER (46L), MIRROR		25	X-4041-068-2	GRILLE ASSY, SPEAKER (46)	(25-29)
* 10	4-081-501-01	HOLDER, MIRROR		26	4-090-952-02	DOOR, TERMINAL	
				27	4-042-192-01	CATCHER, PUSH	
* 11	4-091-246-01	HOLDER (46R), MIRROR		28	3-703-035-11	SHAFT, LID	
12	4-090-957-01	MIRROR (46)		29	4-045-250-01	DAMPER	
13	4-081-063-01	SCREW, DOME WASHER HEX TAP 4X20		30	4-082-291-03	LABEL, CONTROL	
* 14	4-090-956-03	COVER (46), MIRROR		31	4-092-070-11	PANEL ASSY, FRONT	
* 15	4-090-950-01	BOARD, REAR		32	4-090-954-01	DOOR, CONTROL	

NOTE: The components identified by shading and \triangle mark are critical for safety. Replace only with part number specified.

NOTE: Les composants identifiés par un trame et une marque \triangle sont critiques pour la sécurité. Ne les remplacer que par une pièce portant le numéro spécifié.

6-2. CHASSIS

- 7-685-648-79 SCREW +BVTP 3X12 TYPE2 IT-3
- 7-685-661-14 SCREW +BVTP 4X12 TYPE2 IT-3
- ★ 4-635-966-01 SCREW (HEX)

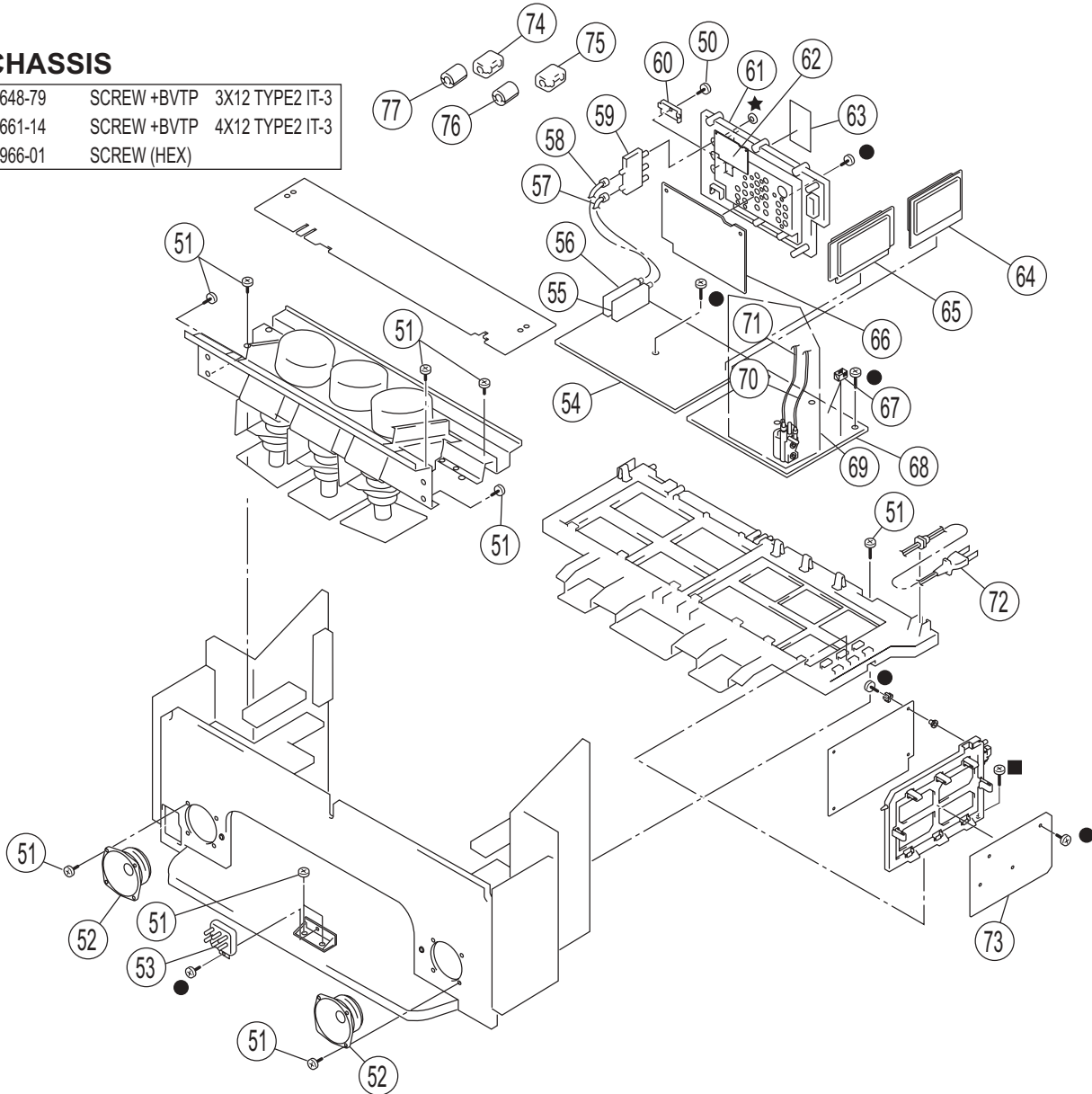

REF. NO.	PART NO.	DESCRIPTION	ASSEMBLY INCLUDES	REF. NO.	PART NO.	DESCRIPTION	ASSEMBLY INCLUDES
51	4-081-063-01	SCREW, DOME WASHER HEX TAP 4X20		67	3-710-578-01	COVER, VOLUME, 6 MOLD	
52	1-544-893-21	SPEAKER (10CM)		\triangle *68	A-1302-180-A	D BOARD, COMPLETE	
\triangle 53	1-223-925-34	RESISTOR ASSY (HIGH-VOLTAGE)				The high voltage leads associated with the FBT on the D board are not included and must be ordered separately. (See 70-71) (SERIAL # 8,700,001 AND UP and # 9,700,001 AND UP)	
☛ 54	A-1302-586-A	A BOARD, COMPLETE	(54, 62, 64, & 65)	\triangle *68	A-1302-708-A	D BOARD, COMPLETE	
☛ 54	A-1405-136-A	A BOARD, MOUNTED				The high voltage leads associated with the FBT on the D board are not included and must be ordered separately. (See 70-71) (SERIAL # 8,000,001 TO 8,099,999 and # 9,000,001 TO 9,099,999)	
55	8-598-594-10	TUNER, FSS BTF-FA421		\triangle 69	1-453-285-51	FBT ASSY, NX-4006//X4P4	(70-71)
56	8-598-593-20	TUNER, FSS BTF-WA421		\triangle 70	1-779-095-51	LEAD ASSY, HIGH-VOLTAGE	
* 57	1-557-056-31	CABLE, P-P		\triangle 71	1-900-260-40	CONNECTOR ASSY, MV	
* 58	1-556-945-21	CABLE, P-P		\triangle 72	1-790-001-22	CORD, AC POWER (WITH CONNECTOR)	
\triangle 59	1-771-787-13	SWITCH, RF ANTENNA		\triangle * 73	A-1302-383-A	G BOARD, COMPLETE	
60	4-069-675-01	CAP, TERMINAL BOARD		74	1-500-021-11	CLAMP, SLEEVE FERRITE	
61	4-089-438-02	BOARD, TERMINAL		75	1-500-082-11	CLAMP, SLEEVE FERRITE	
* 62	A-1300-324-A	UD BOARD, COMPLETE		76	1-469-241-11	CORE, FERRITE (RFC-8 BK)	
63	4-089-194-01	LABEL, TERMINAL		77	1-500-603-11	CLAMP, FERRITE	
* 64	A-1302-179-A	AD BOARD, COMPLETE					
* 65	A-1302-209-A	B BOARD, COMPLETE					
* 66	A-1302-178-A	U BOARD, COMPLETE					

NOTE: The components identified by shading and \triangle mark are critical for safety. Replace only with part number specified.

NOTE: Les composants identifiés par un trame et une marque \triangle sont critiques pour la sécurité. Ne les remplacer que par une pièce portant le numéro spécifié.

6-3. PICTURE TUBE

- 7-685-648-79 SCREW +BVTP 3X12 TYPE2 IT-3
- 7-685-663-71 SCREW +BVTP 4X16 TYPE2 IT-3

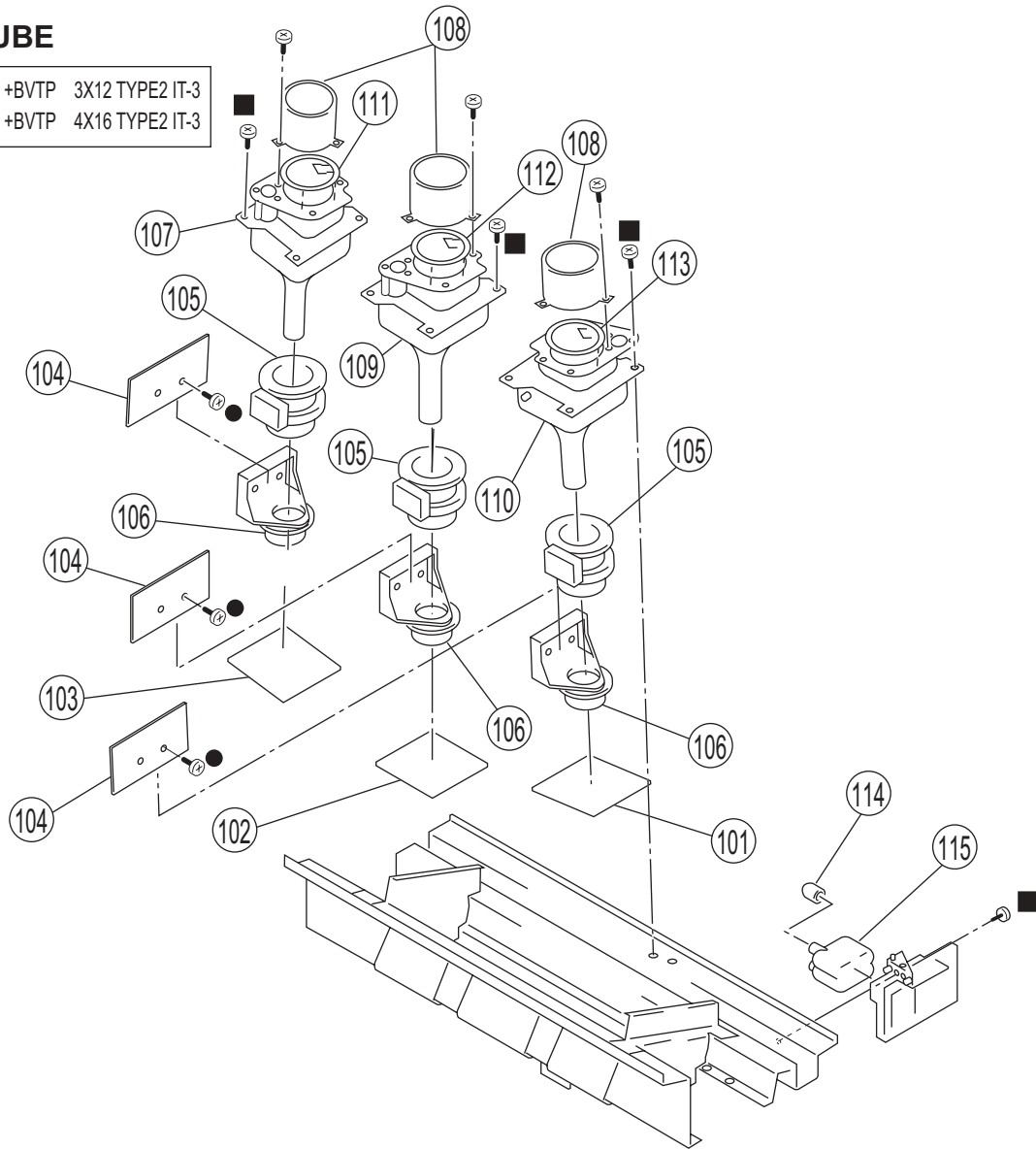

REF. NO.	PART NO.	DESCRIPTION	ASSEMBLY INCLUDES	REF. NO.	PART NO.	DESCRIPTION	ASSEMBLY INCLUDES
* 101	A-1302-183-A	CB BOARD, COMPLETE		108	4-083-751-01	LENS (DELTA 250)	
* 102	A-1302-184-A	CG BOARD, COMPLETE		\triangle 109	A-1604-483-A	COUPLER (G) ASSY, CRT (SERIAL # 8,700,001 AND UP and # 9,700,001 AND UP)	
* 103	A-1302-182-A	CR BOARD, COMPLETE		\triangle 109	8-735-182-05	CRT 07MRC21(G) (SERIAL # 8,000,001 TO 8,099,999 and # 9,000,001 TO 9,099,999)	
* 104	A-1405-146-A	V BOARD, MOUNTED		\triangle 110	A-1604-506-A	COUPLER (B) ASSY, CRT (SERIAL # 8,700,001 AND UP and # 9,700,001 AND UP)	
\triangle 105	1-451-537-13	DEFLECTION YOKE (SERIAL # 8,700,001 AND UP and # 9,700,001 AND UP)		\triangle 110	8-735-183-05	CRT 07MRC21(B) (SERIAL # 8,000,001 TO 8,099,999 and # 9,000,001 TO 9,099,999)	
\triangle 105	1-451-536-41	DEFLECTION YOKE (SERIAL # 8,000,001 TO 8,099,999 and # 9,000,001 TO 9,099,999)		111	4-092-690-01	SHADE (R)	
\triangle 106	1-451-535-12	COIL ASSY, VM (SERIAL # 8,700,001 AND UP and # 9,700,001 AND UP)		112	4-092-691-01	SHADE (G)	
\triangle 106	1-452-790-33	NECK ASSEMBLY (SERIAL # 8,000,001 TO 8,099,999 and # 9,000,001 TO 9,099,999)		113	4-093-242-01	SHADE (B)	
\triangle 107	A-1604-504-A	COUPLER (R) ASSY, CRT (SERIAL # 8,700,001 AND UP and # 9,700,001 AND UP)		114	4-373-137-01	CAP (Z), RUBBER	
\triangle 107	8-735-184-05	CRT 07MRC21(R) (SERIAL # 8,000,001 TO 8,099,999 and # 9,000,001 TO 9,099,999)		\triangle 115	8-598-955-32	BLOCK ASSY, HV HVB-1031	

SECTION 7: ELECTRICAL PARTS LIST

NOTE: The components identified by shading and \triangle mark are critical for safety. Replace only with part number specified.

NOTE: Les composants identifiés par un trame et une marque \triangle sont critiques pour la sécurité. Ne les remplacer que par une pièce portant le numéro spécifié.

The components in this manual identified by the following symbol: \boxtimes indicate parts that have been carefully factory-selected to satisfy regulations regarding X-ray radiation for each set.

Should replacement be required for one of these components, replace only with the value originally used.

* Items marked with an asterisk are not stocked since they are seldom required for routine service. Expect some delay when ordering these components.

RESISTORS

- All resistors are in ohms
- F : nonflammable
- All variable and adjustable resistors have characteristic curve B, unless otherwise noted.





When ordering parts by reference number, please include the board name.

REF.NO.	PART NO.	DESCRIPTION	VALUES		REF.NO.	PART NO.	DESCRIPTION	VALUES																																																																																																																																																																																																																																																																																																									
<div style="display: flex; align-items: center; margin-bottom: 10px;"> CR </div> <p>* A-1302-810-A CR BOARD, COMPLETE 4-382-854-11 SCREW (M3X10), P, SW (+) * 7-651-000-50 GREASE, SILICON (G-746) 200G</p> <p><u>CAPACITOR</u></p> <table style="width: 100%; border-collapse: collapse;"> <tr><td>C7101</td><td>1-164-156-11</td><td>CERAMIC CHIP</td><td>0.1μF</td><td>25V</td></tr> <tr><td>C7102</td><td>1-101-003-00</td><td>CERAMIC</td><td>0.0047μF</td><td>50V</td></tr> <tr><td>C7103</td><td>1-104-570-11</td><td>CERAMIC</td><td>0.001μF</td><td>10% 2KV</td></tr> <tr><td>C7104</td><td>1-107-662-11</td><td>ELECT</td><td>22μF</td><td>20% 350V</td></tr> <tr><td>C7105</td><td>1-162-918-11</td><td>CERAMIC CHIP</td><td>18pF</td><td>5% 50V</td></tr> <tr><td colspan="5"> </td></tr> <tr><td>C7106</td><td>1-126-768-11</td><td>ELECT</td><td>2200μF</td><td>20% 16V</td></tr> <tr><td>C7107</td><td>1-161-830-00</td><td>CERAMIC</td><td>0.0047μF</td><td>500V</td></tr> <tr><td>C7108</td><td>1-101-003-00</td><td>CERAMIC</td><td>0.0047μF</td><td>50V</td></tr> <tr><td>C7109</td><td>1-164-156-11</td><td>CERAMIC CHIP</td><td>0.1μF</td><td>25V</td></tr> <tr><td>C7110</td><td>1-164-156-11</td><td>CERAMIC CHIP</td><td>0.1μF</td><td>25V</td></tr> <tr><td colspan="5"> </td></tr> <tr><td>C7111</td><td>1-126-933-11</td><td>ELECT</td><td>100μF</td><td>20% 16V</td></tr> <tr><td>C7112</td><td>1-164-156-11</td><td>CERAMIC CHIP</td><td>0.1μF</td><td>25V</td></tr> <tr><td>C7114</td><td>1-162-966-11</td><td>CERAMIC CHIP</td><td>0.0022μF</td><td>10% 50V</td></tr> <tr><td>C7117</td><td>1-164-096-11</td><td>CERAMIC</td><td>0.01μF</td><td>50V</td></tr> </table> <p><u>CONNECTOR</u></p> <table style="width: 100%; border-collapse: collapse;"> <tr><td>* CN7102</td><td>1-564-509-11</td><td>PLUG, CONNECTOR 6P</td><td></td><td></td></tr> <tr><td>* CN7103</td><td>1-564-510-11</td><td>PLUG, CONNECTOR 7P</td><td></td><td></td></tr> <tr><td>CN7104</td><td>1-785-879-11</td><td>CONNECTOR, ONE TOUCH</td><td></td><td></td></tr> <tr><td>CN7105</td><td>1-695-915-11</td><td>TAB (CONTACT)</td><td></td><td></td></tr> <tr><td>CN7107</td><td>1-695-915-11</td><td>TAB (CONTACT)</td><td></td><td></td></tr> <tr><td colspan="5"> </td></tr> <tr style="background-color: #f2f2f2;"><td>\triangle CN7108</td><td>1-251-182-11</td><td>SOCKET, CRT</td><td></td><td></td></tr> </table> <p><u>DIODE</u></p> <table style="width: 100%; border-collapse: collapse;"> <tr><td>D7101</td><td>8-719-404-50</td><td>DIODE</td><td>MA111-TX</td><td></td></tr> <tr><td>D7102</td><td>8-719-901-83</td><td>DIODE</td><td>1SS83</td><td></td></tr> <tr><td>D7103</td><td>8-719-901-83</td><td>DIODE</td><td>1SS83</td><td></td></tr> </table>					C7101	1-164-156-11	CERAMIC CHIP	0.1 μ F	25V	C7102	1-101-003-00	CERAMIC	0.0047 μ F	50V	C7103	1-104-570-11	CERAMIC	0.001 μ F	10% 2KV	C7104	1-107-662-11	ELECT	22 μ F	20% 350V	C7105	1-162-918-11	CERAMIC CHIP	18pF	5% 50V						C7106	1-126-768-11	ELECT	2200 μ F	20% 16V	C7107	1-161-830-00	CERAMIC	0.0047 μ F	500V	C7108	1-101-003-00	CERAMIC	0.0047 μ F	50V	C7109	1-164-156-11	CERAMIC CHIP	0.1 μ F	25V	C7110	1-164-156-11	CERAMIC CHIP	0.1 μ F	25V						C7111	1-126-933-11	ELECT	100 μ F	20% 16V	C7112	1-164-156-11	CERAMIC CHIP	0.1 μ F	25V	C7114	1-162-966-11	CERAMIC CHIP	0.0022 μ F	10% 50V	C7117	1-164-096-11	CERAMIC	0.01 μ F	50V	* CN7102	1-564-509-11	PLUG, CONNECTOR 6P			* CN7103	1-564-510-11	PLUG, CONNECTOR 7P			CN7104	1-785-879-11	CONNECTOR, ONE TOUCH			CN7105	1-695-915-11	TAB (CONTACT)			CN7107	1-695-915-11	TAB (CONTACT)								\triangle CN7108	1-251-182-11	SOCKET, CRT			D7101	8-719-404-50	DIODE	MA111-TX		D7102	8-719-901-83	DIODE	1SS83		D7103	8-719-901-83	DIODE	1SS83		<p style="text-align: center;"><u>IC</u></p> <table style="width: 100%; border-collapse: collapse;"> <tr><td>IC7101</td><td>8-759-680-01</td><td>IC</td><td></td><td>TDA6120Q/N2/S1</td></tr> </table> <p style="text-align: center;"><u>JUMPER WIRE</u></p> <table style="width: 100%; border-collapse: collapse;"> <tr><td>JW7104</td><td>1-216-864-11</td><td>SHORT CHIP</td><td></td><td></td></tr> </table> <p style="text-align: center;"><u>COIL</u></p> <table style="width: 100%; border-collapse: collapse;"> <tr><td>L7101</td><td>1-469-555-21</td><td>INDUCTOR</td><td></td><td>10μH</td></tr> <tr><td>L7102</td><td>1-414-855-31</td><td>INDUCTOR</td><td></td><td>1μH</td></tr> <tr><td>L7103</td><td>1-414-855-31</td><td>INDUCTOR</td><td></td><td>1μH</td></tr> </table> <p style="text-align: center;"><u>TRANSISTOR</u></p> <table style="width: 100%; border-collapse: collapse;"> <tr><td>Q7101</td><td>8-729-424-02</td><td>TRANSISTOR</td><td></td><td>2SB709A-QRS-TX</td></tr> <tr><td>Q7102</td><td>8-729-422-27</td><td>TRANSISTOR</td><td></td><td>2SD601A-Q</td></tr> <tr><td>Q7103</td><td>8-729-048-50</td><td>TRANSISTOR</td><td></td><td>2SK3018-T106</td></tr> </table> <p style="text-align: center;"><u>RESISTOR</u></p> <table style="width: 100%; border-collapse: collapse;"> <tr><td>R7101</td><td>1-260-132-11</td><td>CARBON</td><td>560K</td><td>5%</td><td>1/2W</td></tr> <tr><td>R7102</td><td>1-216-813-11</td><td>METAL CHIP</td><td>220</td><td>5%</td><td>1/10W</td></tr> <tr><td>R7103</td><td>1-218-693-11</td><td>METAL CHIP</td><td>1.1K</td><td>0.50%</td><td>1/10W</td></tr> <tr><td>R7104</td><td>1-218-696-11</td><td>METAL CHIP</td><td>1.5K</td><td>0.50%</td><td>1/10W</td></tr> <tr><td>R7105</td><td>1-219-743-11</td><td>METAL</td><td>100</td><td>5%</td><td>1/2W</td></tr> <tr><td colspan="6"> </td></tr> <tr><td>R7106</td><td>1-216-825-11</td><td>METAL CHIP</td><td>2.2K</td><td>5%</td><td>1/10W</td></tr> <tr><td>R7107</td><td>1-260-133-11</td><td>CARBON</td><td>680K</td><td>5%</td><td>1/2W</td></tr> <tr><td>R7108</td><td>1-218-692-11</td><td>METAL CHIP</td><td>1K</td><td>0.50%</td><td>1/10W</td></tr> <tr><td>R7109</td><td>1-216-815-11</td><td>METAL CHIP</td><td>330</td><td>5%</td><td>1/10W</td></tr> <tr><td>R7110</td><td>1-218-703-11</td><td>METAL CHIP</td><td>3K</td><td>0.50%</td><td>1/10W</td></tr> <tr><td colspan="6"> </td></tr> <tr><td>R7111</td><td>1-218-710-11</td><td>METAL CHIP</td><td>5.6K</td><td>0.50%</td><td>1/10W</td></tr> <tr><td>R7112</td><td>1-218-746-11</td><td>METAL CHIP</td><td>180K</td><td>0.50%</td><td>1/10W</td></tr> <tr><td>R7113</td><td>1-218-746-11</td><td>METAL CHIP</td><td>180K</td><td>0.50%</td><td>1/10W</td></tr> <tr><td>R7114</td><td>1-215-925-11</td><td>METAL OXIDE</td><td>22K</td><td>5%</td><td>3W</td></tr> <tr><td>R7116</td><td>1-216-827-11</td><td>METAL CHIP</td><td>3.3K</td><td>5%</td><td>1/10W</td></tr> <tr><td colspan="6"> </td></tr> <tr><td>R7118</td><td>1-216-823-11</td><td>METAL CHIP</td><td>1.5K</td><td>5%</td><td>1/10W</td></tr> <tr><td>R7119</td><td>1-260-320-11</td><td>CARBON</td><td>220</td><td>5%</td><td>1/2W</td></tr> <tr><td>R7120</td><td>1-218-710-11</td><td>METAL CHIP</td><td>5.6K</td><td>0.50%</td><td>1/10W</td></tr> </table>					IC7101	8-759-680-01	IC		TDA6120Q/N2/S1	JW7104	1-216-864-11	SHORT CHIP			L7101	1-469-555-21	INDUCTOR		10 μ H	L7102	1-414-855-31	INDUCTOR		1 μ H	L7103	1-414-855-31	INDUCTOR		1 μ H	Q7101	8-729-424-02	TRANSISTOR		2SB709A-QRS-TX	Q7102	8-729-422-27	TRANSISTOR		2SD601A-Q	Q7103	8-729-048-50	TRANSISTOR		2SK3018-T106	R7101	1-260-132-11	CARBON	560K	5%	1/2W	R7102	1-216-813-11	METAL CHIP	220	5%	1/10W	R7103	1-218-693-11	METAL CHIP	1.1K	0.50%	1/10W	R7104	1-218-696-11	METAL CHIP	1.5K	0.50%	1/10W	R7105	1-219-743-11	METAL	100	5%	1/2W							R7106	1-216-825-11	METAL CHIP	2.2K	5%	1/10W	R7107	1-260-133-11	CARBON	680K	5%	1/2W	R7108	1-218-692-11	METAL CHIP	1K	0.50%	1/10W	R7109	1-216-815-11	METAL CHIP	330	5%	1/10W	R7110	1-218-703-11	METAL CHIP	3K	0.50%	1/10W							R7111	1-218-710-11	METAL CHIP	5.6K	0.50%	1/10W	R7112	1-218-746-11	METAL CHIP	180K	0.50%	1/10W	R7113	1-218-746-11	METAL CHIP	180K	0.50%	1/10W	R7114	1-215-925-11	METAL OXIDE	22K	5%	3W	R7116	1-216-827-11	METAL CHIP	3.3K	5%	1/10W							R7118	1-216-823-11	METAL CHIP	1.5K	5%	1/10W	R7119	1-260-320-11	CARBON	220	5%	1/2W	R7120	1-218-710-11	METAL CHIP	5.6K	0.50%	1/10W
C7101	1-164-156-11	CERAMIC CHIP	0.1 μ F	25V																																																																																																																																																																																																																																																																																																													
C7102	1-101-003-00	CERAMIC	0.0047 μ F	50V																																																																																																																																																																																																																																																																																																													
C7103	1-104-570-11	CERAMIC	0.001 μ F	10% 2KV																																																																																																																																																																																																																																																																																																													
C7104	1-107-662-11	ELECT	22 μ F	20% 350V																																																																																																																																																																																																																																																																																																													
C7105	1-162-918-11	CERAMIC CHIP	18pF	5% 50V																																																																																																																																																																																																																																																																																																													
C7106	1-126-768-11	ELECT	2200 μ F	20% 16V																																																																																																																																																																																																																																																																																																													
C7107	1-161-830-00	CERAMIC	0.0047 μ F	500V																																																																																																																																																																																																																																																																																																													
C7108	1-101-003-00	CERAMIC	0.0047 μ F	50V																																																																																																																																																																																																																																																																																																													
C7109	1-164-156-11	CERAMIC CHIP	0.1 μ F	25V																																																																																																																																																																																																																																																																																																													
C7110	1-164-156-11	CERAMIC CHIP	0.1 μ F	25V																																																																																																																																																																																																																																																																																																													
C7111	1-126-933-11	ELECT	100 μ F	20% 16V																																																																																																																																																																																																																																																																																																													
C7112	1-164-156-11	CERAMIC CHIP	0.1 μ F	25V																																																																																																																																																																																																																																																																																																													
C7114	1-162-966-11	CERAMIC CHIP	0.0022 μ F	10% 50V																																																																																																																																																																																																																																																																																																													
C7117	1-164-096-11	CERAMIC	0.01 μ F	50V																																																																																																																																																																																																																																																																																																													
* CN7102	1-564-509-11	PLUG, CONNECTOR 6P																																																																																																																																																																																																																																																																																																															
* CN7103	1-564-510-11	PLUG, CONNECTOR 7P																																																																																																																																																																																																																																																																																																															
CN7104	1-785-879-11	CONNECTOR, ONE TOUCH																																																																																																																																																																																																																																																																																																															
CN7105	1-695-915-11	TAB (CONTACT)																																																																																																																																																																																																																																																																																																															
CN7107	1-695-915-11	TAB (CONTACT)																																																																																																																																																																																																																																																																																																															
\triangle CN7108	1-251-182-11	SOCKET, CRT																																																																																																																																																																																																																																																																																																															
D7101	8-719-404-50	DIODE	MA111-TX																																																																																																																																																																																																																																																																																																														
D7102	8-719-901-83	DIODE	1SS83																																																																																																																																																																																																																																																																																																														
D7103	8-719-901-83	DIODE	1SS83																																																																																																																																																																																																																																																																																																														
IC7101	8-759-680-01	IC		TDA6120Q/N2/S1																																																																																																																																																																																																																																																																																																													
JW7104	1-216-864-11	SHORT CHIP																																																																																																																																																																																																																																																																																																															
L7101	1-469-555-21	INDUCTOR		10 μ H																																																																																																																																																																																																																																																																																																													
L7102	1-414-855-31	INDUCTOR		1 μ H																																																																																																																																																																																																																																																																																																													
L7103	1-414-855-31	INDUCTOR		1 μ H																																																																																																																																																																																																																																																																																																													
Q7101	8-729-424-02	TRANSISTOR		2SB709A-QRS-TX																																																																																																																																																																																																																																																																																																													
Q7102	8-729-422-27	TRANSISTOR		2SD601A-Q																																																																																																																																																																																																																																																																																																													
Q7103	8-729-048-50	TRANSISTOR		2SK3018-T106																																																																																																																																																																																																																																																																																																													
R7101	1-260-132-11	CARBON	560K	5%	1/2W																																																																																																																																																																																																																																																																																																												
R7102	1-216-813-11	METAL CHIP	220	5%	1/10W																																																																																																																																																																																																																																																																																																												
R7103	1-218-693-11	METAL CHIP	1.1K	0.50%	1/10W																																																																																																																																																																																																																																																																																																												
R7104	1-218-696-11	METAL CHIP	1.5K	0.50%	1/10W																																																																																																																																																																																																																																																																																																												
R7105	1-219-743-11	METAL	100	5%	1/2W																																																																																																																																																																																																																																																																																																												
R7106	1-216-825-11	METAL CHIP	2.2K	5%	1/10W																																																																																																																																																																																																																																																																																																												
R7107	1-260-133-11	CARBON	680K	5%	1/2W																																																																																																																																																																																																																																																																																																												
R7108	1-218-692-11	METAL CHIP	1K	0.50%	1/10W																																																																																																																																																																																																																																																																																																												
R7109	1-216-815-11	METAL CHIP	330	5%	1/10W																																																																																																																																																																																																																																																																																																												
R7110	1-218-703-11	METAL CHIP	3K	0.50%	1/10W																																																																																																																																																																																																																																																																																																												
R7111	1-218-710-11	METAL CHIP	5.6K	0.50%	1/10W																																																																																																																																																																																																																																																																																																												
R7112	1-218-746-11	METAL CHIP	180K	0.50%	1/10W																																																																																																																																																																																																																																																																																																												
R7113	1-218-746-11	METAL CHIP	180K	0.50%	1/10W																																																																																																																																																																																																																																																																																																												
R7114	1-215-925-11	METAL OXIDE	22K	5%	3W																																																																																																																																																																																																																																																																																																												
R7116	1-216-827-11	METAL CHIP	3.3K	5%	1/10W																																																																																																																																																																																																																																																																																																												
R7118	1-216-823-11	METAL CHIP	1.5K	5%	1/10W																																																																																																																																																																																																																																																																																																												
R7119	1-260-320-11	CARBON	220	5%	1/2W																																																																																																																																																																																																																																																																																																												
R7120	1-218-710-11	METAL CHIP	5.6K	0.50%	1/10W																																																																																																																																																																																																																																																																																																												







REF.NO.	PART NO.	DESCRIPTION	VALUES	REF.NO.	PART NO.	DESCRIPTION	VALUES
				Q9007	8-729-120-28	TRANSISTOR	2SC1623-L5L6
				Q9008	8-729-045-04	TRANSISTOR	2SC5511
				Q9009	8-729-045-05	TRANSISTOR	2SA2005
<p>* A-1405-146-A V BOARD, MOUNTED</p>				RESISTOR			
<p>4-382-854-11 SCREW (M3X10), P, SW (+)</p>							
<p>* 7-651-000-50 GREASE,SILICON (G-746) 200G</p>							
CAPACITOR							
C9002	1-104-999-11	MYLAR	0.1µF 5% 200V	R9002	1-216-805-11	METAL CHIP	47 5% 1/10W
C9003	1-125-891-11	CERAMIC CHIP	0.47µF 10% 10V	R9004	1-216-820-11	METAL CHIP	820 5% 1/10W
C9006	1-126-935-11	ELECT	470µF 20% 16V	R9005	1-216-829-11	METAL CHIP	4.7K 5% 1/10W
C9007	1-126-933-11	ELECT	100µF 20% 16V	R9006	1-216-829-11	METAL CHIP	4.7K 5% 1/10W
C9008	1-126-935-11	ELECT	470µF 20% 16V	R9007	1-216-809-11	METAL CHIP	100 5% 1/10W
C9009	1-126-933-11	ELECT	100µF 20% 16V	R9008	1-216-803-11	METAL CHIP	33 5% 1/10W
C9010	1-107-667-11	ELECT	2.2µF 20% 400V	R9009	1-216-809-11	METAL CHIP	100 5% 1/10W
C9011	1-107-364-11	MYLAR	0.01µF 10% 200V	R9010	1-216-813-11	METAL CHIP	220 5% 1/10W
C9012	1-107-364-11	MYLAR	0.01µF 10% 200V	R9011	1-216-864-11	SHORT CHIP	
C9013	1-162-964-11	CERAMIC CHIP	0.001µF 10% 50V	R9012	1-216-823-11	METAL CHIP	1.5K 5% 1/10W
C9014	1-162-964-11	CERAMIC CHIP	0.001µF 10% 50V	R9013	1-216-805-11	METAL CHIP	47 5% 1/10W
C9015	1-126-935-11	ELECT	470µF 20% 16V	R9014	1-216-805-11	METAL CHIP	47 5% 1/10W
C9017	1-104-999-11	MYLAR	0.1µF 5% 200V	R9015	1-216-833-11	METAL CHIP	10K 5% 1/10W
C9018	1-107-638-11	ELECT	33µF 20% 160V	R9016	1-249-414-11	CARBON	560 5% 1/4W
C9019	1-126-935-11	ELECT	470µF 20% 16V	R9017	1-249-435-11	CARBON	33K 5% 1/4W
CONNECTOR				R9018	1-249-435-11	CARBON	33K 5% 1/4W
* CN9001	1-564-508-11	PLUG, CONNECTOR	5P	R9019	1-249-414-11	CARBON	560 5% 1/4W
* CN9002	1-770-723-11	CONNECTOR, BOARD TO BOARD	8P	R9020	1-216-799-11	METAL CHIP	15 5% 1/10W
DIODE				R9021	1-216-799-11	METAL CHIP	15 5% 1/10W
D9001	8-719-988-61	DIODE	1SS355TE-17	R9022	1-249-421-11	CARBON	2.2K 5% 1/4W
D9002	8-719-988-61	DIODE	1SS355TE-17	R9023	1-249-421-11	CARBON	2.2K 5% 1/4W
D9003	8-719-988-61	DIODE	1SS355TE-17	R9024	1-249-405-11	CARBON	100 5% 1/4W
D9004	8-719-988-61	DIODE	1SS355TE-17	R9025	1-249-385-11	CARBON	2.2 5% 1/4W
D9005	8-719-510-02	DIODE	D1NS4	R9027	1-249-385-11	CARBON	2.2 5% 1/4W
D9006	8-719-110-56	DIODE	RD22ESB1	R9028	1-249-405-11	CARBON	100 5% 1/4W
D9007	8-719-110-56	DIODE	RD22ESB1	R9029	1-215-913-11	METAL OXIDE	220 5% 3W
COIL				R9030	1-249-377-11	CARBON	0.47 5% 1/4W
L9001	1-412-525-31	INDUCTOR	10µH	R9031	1-249-385-11	CARBON	2.2 5% 1/4W
TRANSISTOR				R9032	1-249-385-11	CARBON	2.2 5% 1/4W
Q9002	8-729-120-28	TRANSISTOR	2SC1623-L5L6	R9033	1-249-436-11	CARBON	39K 5% 1/4W
Q9003	8-729-120-28	TRANSISTOR	2SC1623-L5L6	R9034	1-249-436-11	CARBON	39K 5% 1/4W
Q9004	8-729-026-49	TRANSISTOR	2SA1037AK-T146-R				
Q9005	8-729-120-28	TRANSISTOR	2SC1623-L5L6				
Q9006	8-729-026-49	TRANSISTOR	2SA1037AK-T146-R				

NOTE: The components identified by shading and  mark are critical for safety. Replace only with part number specified.

NOTE: Les composants identifiés par un trame et une marque  sont critiques pour la sécurité. Ne les remplacer que par une pièce portant le numéro spécifique.



REF.NO.	PART NO.	DESCRIPTION	VALUES	REF.NO.	PART NO.	DESCRIPTION	VALUES
D5005	8-719-083-45	DIODE	31DF4N-FC5	FERRITE BEAD			
D5006	8-719-052-37	DIODE	F10P04Q	FB5001	1-410-396-41	FERRITE	0.45µH
D5007	8-719-988-61	DIODE	1SS355TE-17	FB5002	1-410-396-41	FERRITE	0.45µH
D5008	8-719-028-45	DIODE	D2L20U	FB5003	1-410-396-41	FERRITE	0.45µH
D5009	8-719-028-45	DIODE	D2L20U	FB5004	1-410-396-41	FERRITE	0.45µH
D5010	8-719-200-31	DIODE	21DQ05	FB5005	1-410-396-41	FERRITE	0.45µH
D5011	8-719-988-61	DIODE	1SS355TE-17	FB5006	1-410-396-41	FERRITE	0.45µH
D5012	8-719-056-93	DIODE	UDZ-TE-17-18B	FB6001	1-410-396-41	FERRITE	0.45µH
D5013	8-719-069-56	DIODE	UDZSTE-176.2B	FB6004	1-216-295-91	SHORT CHIP	
D5014	8-719-988-61	DIODE	1SS355TE-17	FB6005	1-216-295-91	SHORT CHIP	
D5015	8-719-988-61	DIODE	1SS355TE-17	FB6006	1-216-295-91	SHORT CHIP	
D5016	8-719-083-44	DIODE	FSQ05A04	FB6007	1-216-295-91	SHORT CHIP	
D5017	8-719-073-25	DIODE	S1VBA20	FB6013	1-410-397-21	FERRITE	1.1µH
D5018	8-719-056-84	DIODE	UDZ-TE-17-7.5B	FB6014	1-410-397-21	FERRITE	1.1µH
D5019	8-719-988-61	DIODE	1SS355TE-17	FB6015	1-410-397-21	FERRITE	1.1µH
D5020	8-719-988-61	DIODE	1SS355TE-17	FB6016	1-410-397-21	FERRITE	1.1µH
D5021	8-719-988-61	DIODE	1SS355TE-17	FUSE HOLDER			
D5022	8-719-988-61	DIODE	1SS355TE-17		FH6001	1-533-223-11	FUSE HOLDER 0A 0V
D5023	8-719-988-61	DIODE	1SS355TE-17		FH6002	1-533-223-11	FUSE HOLDER 0A 0V
D5024	8-719-988-61	DIODE	1SS355TE-17	IC			
D5025	8-719-988-61	DIODE	1SS355TE-17		IC501	8-749-012-13	IC DM-58
D5026	8-719-988-61	DIODE	1SS355TE-17	IC5002	8-759-103-93	IC	UPC393C
D5027	8-719-069-54	DIODE	UDZSTE-175.1B	IC5003	8-759-701-84	IC	NJM7905FA
D5031	8-719-988-61	DIODE	1SS355TE-17	IC5004	8-759-640-19	IC	PQ1CG2032FZ
D5033	8-719-988-61	DIODE	1SS355TE-17		IC5005	8-759-198-31	IC UPC1093J-1-T
D5034	8-719-083-60	DIODE	UDZSTE-174.7B	IC5006	8-759-471-81	IC	PQ05RD11
D6001	8-719-988-61	DIODE	1SS355TE-17	IC6003	8-759-670-30	IC	MCZ3001D
D6002	8-719-948-45	DIODE	ERA22-08	CHIP CONDUCTOR			
D6003	8-719-070-63	DIODE	PDZ10B-115	JR5002	1-216-864-11	SHORT CHIP	
D6004	8-719-988-61	DIODE	1SS355TE-17	JR5003	1-216-295-91	SHORT CHIP	
D6005	8-719-988-61	DIODE	1SS355TE-17	COIL			
D6006	8-719-063-70	DIODE	D1NL20U	L5001	1-412-523-41	INDUCTOR	6.8µH
D6007	8-719-022-99	DIODE	D6SB60L	L5002	1-412-523-41	INDUCTOR	6.8µH
D6009	8-719-083-60	DIODE	UDZSTE-174.7B	L5003	1-412-529-11	INDUCTOR	22µH
D6011	8-719-988-61	DIODE	1SS355TE-17	L5004	1-412-531-31	INDUCTOR	33µH
D6012	6-500-158-01	DIODE	10ERA60-TA2B5	L5005	1-412-527-11	INDUCTOR	15µH
D6019	8-719-083-60	DIODE	UDZSTE-174.7B	L5006	1-412-533-21	INDUCTOR	47µH
D6023	8-719-068-00	DIODE	ERC04-06SE	L5007	1-412-533-21	INDUCTOR	47µH
D6024	8-719-068-00	DIODE	ERC04-06SE	L5008	1-412-529-11	INDUCTOR	22µH
D6030	8-719-063-70	DIODE	D1NL20U	L5009	1-412-529-11	INDUCTOR	22µH
FUSE							
	F6001	1-576-193-11	FUSE 6.3A 125V				

NOTE: The components identified by shading and \triangle mark are critical for safety. Replace only with part number specified.

NOTE: Les composants identifiés par un trame et une marque \triangle sont critiques pour la sécurité. Ne les remplacer que par une pièce portant le numéro spécifique.



REF.NO.	PART NO.	DESCRIPTION	VALUES	REF.NO.	PART NO.	DESCRIPTION	VALUES
L5010	1-412-521-31	INDUCTOR	4.7 μ H	R5019	1-216-857-11	METAL CHIP	1M 5% 1/10W
L5011	1-412-521-31	INDUCTOR	4.7 μ H	R5020	1-216-821-11	METAL CHIP	1K 5% 1/10W
L5012	1-406-663-21	INDUCTOR	47 μ H	R5021	1-216-821-11	METAL CHIP	1K 5% 1/10W
L5013	1-412-525-31	INDUCTOR	10 μ H	\triangle R5022	1-218-708-11	METAL CHIP	4.7K 0.50% 1/10W
L5014	1-406-663-21	INDUCTOR	47 μ H	\triangle R5023	1-218-750-11	METAL CHIP	270K 0.50% 1/10W
L5015	1-424-862-11	INDUCTOR	33 μ H	R5024	1-218-682-11	METAL CHIP	390 0.50% 1/10W
L5016	1-406-663-21	INDUCTOR	47 μ H	R5025	1-218-697-11	METAL CHIP	1.6K 0.50% 1/10W
L5017	1-412-537-31	INDUCTOR	100 μ H	R5026	1-216-833-11	METAL CHIP	10K 5% 1/10W
\triangle L6001	1-437-479-11	TRANSFORMER, LINE FILTER		R5027	1-216-821-11	METAL CHIP	1K 5% 1/10W
\triangle L6002	1-437-479-11	TRANSFORMER, LINE FILTER		R5028	1-216-821-11	METAL CHIP	1K 5% 1/10W
L6003	1-424-862-11	INDUCTOR	33 μ H	R5029	1-216-837-11	METAL CHIP	22K 5% 1/10W
PHOTO COUPLER				R5030	1-216-837-11	METAL CHIP	22K 5% 1/10W
\triangle PH6001	8-749-924-35	PHOTO COUPLER	ON3171-R	R5032	1-249-415-11	CARBON	680 5% 1/4W
\triangle PH6002	8-749-924-35	PHOTO COUPLER	ON3171-R	R5034	1-216-833-11	METAL CHIP	10K 5% 1/10W
IC LINK				R5035	1-216-819-11	METAL CHIP	680 5% 1/10W
\triangle PS5001	1-533-597-31	IC LINK	5A 90V	R5036	1-216-819-11	METAL CHIP	680 5% 1/10W
\triangle PS5002	1-533-597-31	IC LINK	5A 90V	R5037	1-216-821-11	METAL CHIP	1K 5% 1/10W
TRANSISTOR				R5038	1-216-821-11	METAL CHIP	1K 5% 1/10W
Q5001	8-729-050-50	TRANSISTOR	2SD1782K-T146-R	R5039	1-216-864-11	SHORT CHIP	
Q5002	8-729-120-28	TRANSISTOR	2SC1623-L5L6	R5040	1-216-833-11	METAL CHIP	10K 5% 1/10W
Q5003	8-729-026-49	TRANSISTOR	2SA1037AK-T146-R	R5041	1-215-866-11	METAL OXIDE	330 5% 1W
Q5004	8-729-120-28	TRANSISTOR	2SC1623-L5L6	R5042	1-216-833-11	METAL CHIP	10K 5% 1/10W
Q5005	8-729-027-23	TRANSISTOR	DTA114EKA-T146	R5043	1-216-821-11	METAL CHIP	1K 5% 1/10W
Q5006	8-729-901-87	TRANSISTOR	2SC2411K-CQ	R5044	1-216-821-11	METAL CHIP	1K 5% 1/10W
Q5007	8-729-026-49	TRANSISTOR	2SA1037AK-T146-R	R5045	1-216-832-11	METAL CHIP	8.2K 5% 1/10W
Q6005	8-729-052-32	TRANSISTOR	IRFIB7N50A-LF31	R5047	1-216-833-11	METAL CHIP	10K 5% 1/10W
Q6006	8-729-052-32	TRANSISTOR	IRFIB7N50A-LF31	R5048	1-216-833-11	METAL CHIP	10K 5% 1/10W
RESISTOR				R6002	1-240-251-11	CEMENTED	6.8 5% 10W
R5005	1-218-867-11	METAL CHIP	6.8K 0.50% 1/10W	R6003	1-260-328-11	CARBON	1K 5% 1/2W
R5006	1-216-833-11	METAL CHIP	10K 5% 1/10W	R6004	1-216-829-11	METAL CHIP	4.7K 5% 1/10W
R5007	1-249-377-11	CARBON	0.47 5% 1/4W	R6006	1-216-430-11	METAL OXIDE	390 5% 1W
R5010	1-247-903-00	CARBON	1M 5% 1/4W	R6007	1-216-823-11	METAL CHIP	1.5K 5% 1/10W
R5011	1-216-818-11	METAL CHIP	560 5% 1/10W	R6008	1-216-845-11	METAL CHIP	100K 5% 1/10W
R5012	1-216-361-00	METAL OXIDE	0.22 5% 2W	\triangle R6015	1-219-776-11	CARBON	2.2M 10% 1/2W
R5013	1-216-833-11	METAL CHIP	10K 5% 1/10W	R6036	1-218-715-11	METAL CHIP	9.1K 0.50% 1/10W
R5014	1-216-829-11	METAL CHIP	4.7K 5% 1/10W	R6037	1-215-481-00	METAL	330K 1% 1/4W
R5015	1-218-708-11	METAL CHIP	4.7K 0.50% 1/10W	R6038	1-215-481-00	METAL	330K 1% 1/4W
R5016	1-216-833-11	METAL CHIP	10K 5% 1/10W	R6039	1-216-851-11	METAL CHIP	330K 5% 1/10W
R5017	1-216-829-11	METAL CHIP	4.7K 5% 1/10W	R6040	1-215-481-00	METAL	330K 1% 1/4W
R5018	1-216-821-11	METAL CHIP	1K 5% 1/10W	R6041	1-218-668-11	METAL CHIP	100 0.50% 1/10W
				R6042	1-218-719-11	METAL CHIP	13K 0.50% 1/10W
				R6045	1-218-675-11	METAL CHIP	200 0.50% 1/10W
				R6046	1-216-813-11	METAL CHIP	220 5% 1/10W
				R6047	1-216-813-11	METAL CHIP	220 5% 1/10W

NOTE: The components identified by shading and \triangle mark are critical for safety. Replace only with part number specified.

NOTE: Les composants identifiés par un trame et une marque \triangle sont critiques pour la sécurité. Ne les remplacer que par une pièce portant le numéro spécifique.



REF.NO.	PART NO.	DESCRIPTION	VALUES			REF.NO.	PART NO.	DESCRIPTION	VALUES		
R6050	1-249-417-11	CARBON	1K	5%	1/4W	C7013	1-162-970-11	CERAMIC CHIP	0.01μF	10%	25V
R6054	1-249-393-11	CARBON	10	5%	1/4W	C7014	1-162-970-11	CERAMIC CHIP	0.01μF	10%	25V
R6056	1-260-131-11	CARBON	470K	5%	1/2W	C7015	1-162-970-11	CERAMIC CHIP	0.01μF	10%	25V
R6057	1-260-131-11	CARBON	470K	5%	1/2W	C7016	1-162-970-11	CERAMIC CHIP	0.01μF	10%	25V
R6058	1-249-393-11	CARBON	10	5%	1/4W	C7017	1-164-156-11	CERAMIC CHIP	0.1μF		25V
R6062	1-216-833-11	METAL CHIP	10K	5%	1/10W	C7018	1-162-923-11	CERAMIC CHIP	47pF	5%	50V
R6063	1-216-833-11	METAL CHIP	10K	5%	1/10W	C7019	1-162-923-11	CERAMIC CHIP	47pF	5%	50V
R6064	1-202-933-61	FUSIBLE	0.1	10%	1/2W	C7020	1-162-923-11	CERAMIC CHIP	47pF	5%	50V
R6076	1-243-979-71	METAL OXIDE	0.1	5%	2W	C7021	1-124-779-00	ELECT CHIP	10μF	20%	16V
R6080	1-243-979-71	METAL OXIDE	0.1	5%	2W	C7022	1-115-416-11	CERAMIC CHIP	0.001μF	5%	25V
R6081	1-249-393-11	CARBON	10	5%	1/4W	C7023	1-162-927-11	CERAMIC CHIP	100pF	5%	50V
RELAY						C7024	1-124-779-00	ELECT CHIP	10μF	20%	16V
\triangle RY6002	1-755-395-11	RELAY (AC POWER)				C7025	1-164-156-11	CERAMIC CHIP	0.1μF		25V
\triangle RY6003	1-755-395-11	RELAY (AC POWER)				C7026	1-124-779-00	ELECT CHIP	10μF	20%	16V
TRANSFORMER						C7027	1-164-156-11	CERAMIC CHIP	0.1μF		25V
\triangle T6001	1-437-436-11	CONVERTER TRANSFORMER (PIT)				C7028	1-164-156-11	CERAMIC CHIP	0.1μF		25V
T6004	1-435-675-11	TRANSFORMER, STANDBY				C7029	1-164-156-11	CERAMIC CHIP	0.1μF		25V
THERMISTOR						C7030	1-162-927-11	CERAMIC CHIP	100pF	5%	50V
TH6002	1-804-475-21	POSISTOR				C7031	1-162-927-11	CERAMIC CHIP	100pF	5%	50V
VARISTOR						C7032	1-162-927-11	CERAMIC CHIP	100pF	5%	50V
VD6001	1-801-073-31	VARISTOR	ERZV14D471			C7033	1-124-779-00	ELECT CHIP	10μF	20%	16V
UD						C7034	1-164-156-11	CERAMIC CHIP	0.1μF		25V
Due to the complexity of this board, performing component level field repairs is not recommended. If service is required, complete board replacement is the preferred repair method.						C7035	1-164-156-11	CERAMIC CHIP	0.1μF		25V
Data is provided for reference only.						C7036	1-164-156-11	CERAMIC CHIP	0.1μF		25V
*	A-1300-324-A	UD BOARD, COMPLETE				C7037	1-164-156-11	CERAMIC CHIP	0.1μF		25V
CAPACITOR						C7038	1-164-156-11	CERAMIC CHIP	0.1μF		25V
C7001	1-126-395-11	ELECT CHIP	22μF	20%	16V	C7039	1-126-395-11	ELECT CHIP	22μF	20%	16V
C7002	1-162-917-11	CERAMIC CHIP	15pF	5%	50V	C7040	1-162-921-11	CERAMIC CHIP	33pF	5%	50V
C7004	1-162-970-11	CERAMIC CHIP	0.01μF	10%	25V	C7041	1-164-156-11	CERAMIC CHIP	0.1μF		25V
C7005	1-162-970-11	CERAMIC CHIP	0.01μF	10%	25V	C7042	1-164-156-11	CERAMIC CHIP	0.1μF		25V
C7006	1-124-779-00	ELECT CHIP	10μF	20%	16V	C7043	1-164-156-11	CERAMIC CHIP	0.1μF		25V
C7007	1-162-917-11	CERAMIC CHIP	15pF	5%	50V	C7044	1-164-156-11	CERAMIC CHIP	0.1μF		25V
C7008	1-162-970-11	CERAMIC CHIP	0.01μF	10%	25V	C7045	1-164-156-11	CERAMIC CHIP	0.1μF		25V
C7010	1-162-970-11	CERAMIC CHIP	0.01μF	10%	25V	C7046	1-164-156-11	CERAMIC CHIP	0.1μF		25V
C7011	1-162-970-11	CERAMIC CHIP	0.01μF	10%	25V	C7047	1-164-156-11	CERAMIC CHIP	0.1μF		25V
C7012	1-124-779-00	ELECT CHIP	10μF	20%	16V	C7048	1-164-156-11	CERAMIC CHIP	0.1μF		25V
						C7049	1-164-156-11	CERAMIC CHIP	0.1μF		25V
						C7050	1-164-156-11	CERAMIC CHIP	0.1μF		25V
						C7051	1-164-156-11	CERAMIC CHIP	0.1μF		25V
						C7052	1-164-156-11	CERAMIC CHIP	0.1μF		25V
						C7053	1-164-156-11	CERAMIC CHIP	0.1μF		25V
						C7056	1-126-395-11	ELECT CHIP	22μF	20%	16V
						C7057	1-162-921-11	CERAMIC CHIP	33pF	5%	50V
						C7058	1-164-156-11	CERAMIC CHIP	0.1μF		25V



REF.NO.	PART NO.	DESCRIPTION	VALUES			REF.NO.	PART NO.	DESCRIPTION	VALUES		
R7065	1-216-833-11	METAL CHIP	10K	5%	1/10W	C3	1-164-156-11	CERAMIC CHIP	0.1μF		25V
R7066	1-218-694-11	METAL CHIP	1.2K	0.50%	1/10W	C4	1-164-156-11	CERAMIC CHIP	0.1μF		25V
R7067	1-216-833-11	METAL CHIP	10K	5%	1/10W	C5	1-164-156-11	CERAMIC CHIP	0.1μF		25V
R7068	1-216-801-11	METAL CHIP	22	5%	1/10W	C6	1-164-156-11	CERAMIC CHIP	0.1μF		25V
R7069	1-216-801-11	METAL CHIP	22	5%	1/10W	C7	1-126-933-11	ELECT	100μF	20%	16V
R7071	1-216-803-11	METAL CHIP	33	5%	1/10W	C8	1-164-156-11	CERAMIC CHIP	0.1μF		25V
R7072	1-216-803-11	METAL CHIP	33	5%	1/10W	C9	1-115-416-11	CERAMIC CHIP	0.001μF	5%	25V
R7075	1-218-676-11	METAL CHIP	220	0.50%	1/10W	C10	1-162-974-11	CERAMIC CHIP	0.01μF		50V
R7080	1-218-704-11	METAL CHIP	3.3K	0.50%	1/10W	C11	1-126-933-11	ELECT	100μF	20%	16V
R7087	1-218-680-11	METAL CHIP	330	0.50%	1/10W	C12	1-126-933-11	ELECT	100μF	20%	16V
R7096	1-216-833-11	METAL CHIP	10K	5%	1/10W	C13	1-164-739-11	CERAMIC CHIP	560pF	5%	50V
R7097	1-216-809-11	METAL CHIP	100	5%	1/10W	C14	1-165-176-11	CERAMIC CHIP	0.047μF	10%	16V
R7098	1-216-809-11	METAL CHIP	100	5%	1/10W	C15	1-164-392-11	CERAMIC CHIP	390pF	5%	50V
R7099	1-216-809-11	METAL CHIP	100	5%	1/10W	C16	1-162-927-11	CERAMIC CHIP	100pF	5%	50V
R7101	1-216-864-11	SHORT CHIP				C17	1-115-414-11	CERAMIC CHIP	820pF	5%	25V
R7106	1-216-833-11	METAL CHIP	10K	5%	1/10W	C18	1-162-919-11	CERAMIC CHIP	22pF	5%	50V
R7108	1-216-805-11	METAL CHIP	47	5%	1/10W	C19	1-162-919-11	CERAMIC CHIP	22pF	5%	50V
R7109	1-216-805-11	METAL CHIP	47	5%	1/10W	C20	1-164-156-11	CERAMIC CHIP	0.1μF		25V
R7111	1-216-864-11	SHORT CHIP				C21	1-164-156-11	CERAMIC CHIP	0.1μF		25V
R7112	1-216-864-11	SHORT CHIP				C22	1-164-156-11	CERAMIC CHIP	0.1μF		25V
R7113	1-216-864-11	SHORT CHIP				C23	1-162-974-11	CERAMIC CHIP	0.01μF		50V
R7114	1-218-700-11	METAL CHIP	2.2K	0.50%	1/10W	C24	1-126-947-11	ELECT	47μF	20%	35V
R7115	1-218-700-11	METAL CHIP	2.2K	0.50%	1/10W	C25	1-126-947-11	ELECT	47μF	20%	35V
R7116	1-218-700-11	METAL CHIP	2.2K	0.50%	1/10W	C26	1-164-156-11	CERAMIC CHIP	0.1μF		25V
R7117	1-218-668-11	METAL CHIP	100	0.50%	1/10W	C27	1-126-947-11	ELECT	47μF	20%	35V
R7119	1-218-668-11	METAL CHIP	100	0.50%	1/10W	C28	1-162-974-11	CERAMIC CHIP	0.01μF		50V
R7121	1-216-864-11	SHORT CHIP				C29	1-164-156-11	CERAMIC CHIP	0.1μF		25V
R7123	1-218-704-11	METAL CHIP	3.3K	0.50%	1/10W	C30	1-164-156-11	CERAMIC CHIP	0.1μF		25V
R7124	1-218-680-11	METAL CHIP	330	0.50%	1/10W	C31	1-164-156-11	CERAMIC CHIP	0.1μF		25V
R7125	1-218-700-11	METAL CHIP	2.2K	0.50%	1/10W	C32	1-126-964-11	ELECT	10μF	20%	50V
R7126	1-216-864-11	SHORT CHIP				C34	1-162-974-11	CERAMIC CHIP	0.01μF		50V
CRYSTAL						C35	1-126-947-11	ELECT	47μF	20%	35V
X7001	1-795-568-21	VIBRATOR, CRYSTAL				C36	1-164-156-11	CERAMIC CHIP	0.1μF		25V
X7002	1-795-567-21	VIBRATOR, CRYSTAL				C37	1-162-974-11	CERAMIC CHIP	0.01μF		50V
A						C38	1-126-934-11	ELECT	220μF	20%	16V
*	A-1302-177-A	A BOARD, COMPLETE				C39	1-164-156-11	CERAMIC CHIP	0.1μF		25V
CAPACITOR						C40	1-162-974-11	CERAMIC CHIP	0.01μF		50V
C1	1-126-933-11	ELECT	100μF	20%	16V	C41	1-164-156-11	CERAMIC CHIP	0.1μF		25V
C2	1-104-665-11	ELECT	100μF	20%	25V	C42	1-126-934-11	ELECT	220μF	20%	16V
						C43	1-164-156-11	CERAMIC CHIP	0.1μF		25V
						C44	1-126-947-11	ELECT	47μF	20%	35V
						C45	1-162-979-11	CERAMIC CHIP	0.0027μF	10%	50V
						C46	1-162-974-11	CERAMIC CHIP	0.01μF		50V
						C47	1-162-979-11	CERAMIC CHIP	0.0027μF	10%	50V



REF.NO.	PART NO.	DESCRIPTION	VALUES	REF.NO.	PART NO.	DESCRIPTION	VALUES
C49	1-164-156-11	CERAMIC CHIP	0.1μF 25V	C102	1-107-826-11	CERAMIC CHIP	0.1μF 10% 16V
C51	1-126-947-11	ELECT	47μF 20% 35V	C103	1-126-964-11	ELECT	10μF 20% 50V
C52	1-162-974-11	CERAMIC CHIP	0.01μF 50V	C104	1-164-156-11	CERAMIC CHIP	0.1μF 25V
C53	1-164-156-11	CERAMIC CHIP	0.1μF 25V	C105	1-164-156-11	CERAMIC CHIP	0.1μF 25V
C54	1-162-979-11	CERAMIC CHIP	0.0027μF 10% 50V	C106	1-126-933-11	ELECT	100μF 20% 16V
C55	1-162-979-11	CERAMIC CHIP	0.0027μF 10% 50V	C107	1-107-826-11	CERAMIC CHIP	0.1μF 10% 16V
C56	1-164-156-11	CERAMIC CHIP	0.1μF 25V	C108	1-162-917-11	CERAMIC CHIP	15pF 5% 50V
C57	1-164-156-11	CERAMIC CHIP	0.1μF 25V	C109	1-162-917-11	CERAMIC CHIP	15pF 5% 50V
C59	1-164-156-11	CERAMIC CHIP	0.1μF 25V	C110	1-164-156-11	CERAMIC CHIP	0.1μF 25V
C60	1-164-156-11	CERAMIC CHIP	0.1μF 25V	C111	1-164-156-11	CERAMIC CHIP	0.1μF 25V
C61	1-164-156-11	CERAMIC CHIP	0.1μF 25V	C112	1-164-156-11	CERAMIC CHIP	0.1μF 25V
C62	1-126-947-11	ELECT	47μF 20% 35V	C113	1-164-156-11	CERAMIC CHIP	0.1μF 25V
C63	1-126-935-11	ELECT	470μF 20% 16V	C115	1-162-917-11	CERAMIC CHIP	15pF 5% 50V
C65	1-164-156-11	CERAMIC CHIP	0.1μF 25V	C116	1-162-917-11	CERAMIC CHIP	15pF 5% 50V
C66	1-164-156-11	CERAMIC CHIP	0.1μF 25V	C119	1-126-933-11	ELECT	100μF 20% 16V
C67	1-164-156-11	CERAMIC CHIP	0.1μF 25V	C120	1-126-933-11	ELECT	100μF 20% 16V
C68	1-164-156-11	CERAMIC CHIP	0.1μF 25V	C123	1-162-966-11	CERAMIC CHIP	0.0022μF 10% 50V
C69	1-164-156-11	CERAMIC CHIP	0.1μF 25V	C124	1-164-346-11	CERAMIC CHIP	1μF 16V
C70	1-164-156-11	CERAMIC CHIP	0.1μF 25V	C125	1-164-156-11	CERAMIC CHIP	0.1μF 25V
C73	1-164-156-11	CERAMIC CHIP	0.1μF 25V	C128	1-162-960-11	CERAMIC CHIP	220pF 10% 50V
C74	1-126-964-11	ELECT	10μF 20% 50V	C129	1-165-176-11	CERAMIC CHIP	0.047μF 10% 16V
C75	1-164-156-11	CERAMIC CHIP	0.1μF 25V	C130	1-162-970-11	CERAMIC CHIP	0.01μF 10% 25V
C76	1-162-966-11	CERAMIC CHIP	0.0022μF 10% 50V	C131	1-126-961-11	ELECT	2.2μF 20% 50V
C77	1-164-156-11	CERAMIC CHIP	0.1μF 25V	C132	1-126-935-11	ELECT	470μF 20% 16V
C78	1-104-665-11	ELECT	100μF 20% 25V	C133	1-126-964-11	ELECT	10μF 20% 50V
C79	1-126-933-11	ELECT	100μF 20% 16V	C134	1-164-156-11	CERAMIC CHIP	0.1μF 25V
C80	1-126-967-11	ELECT	47μF 20% 50V	C135	1-126-964-11	ELECT	10μF 20% 50V
C81	1-104-665-11	ELECT	100μF 20% 25V	C136	1-164-156-11	CERAMIC CHIP	0.1μF 25V
C82	1-164-156-11	CERAMIC CHIP	0.1μF 25V	C137	1-126-964-11	ELECT	10μF 20% 50V
C83	1-164-156-11	CERAMIC CHIP	0.1μF 25V	C138	1-126-964-11	ELECT	10μF 20% 50V
C84	1-126-933-11	ELECT	100μF 20% 16V	C139	1-126-964-11	ELECT	10μF 20% 50V
C86	1-162-970-11	CERAMIC CHIP	0.01μF 10% 25V	C140	1-126-933-11	ELECT	100μF 20% 16V
C87	1-126-960-11	ELECT	1μF 20% 50V	C141	1-126-933-11	ELECT	100μF 20% 16V
C88	1-126-933-11	ELECT	100μF 20% 16V	C142	1-164-156-11	CERAMIC CHIP	0.1μF 25V
C90	1-126-964-11	ELECT	10μF 20% 50V	C143	1-164-156-11	CERAMIC CHIP	0.1μF 25V
C92	1-164-156-11	CERAMIC CHIP	0.1μF 25V	C144	1-126-964-11	ELECT	10μF 20% 50V
C93	1-126-964-11	ELECT	10μF 20% 50V	C145	1-162-970-11	CERAMIC CHIP	0.01μF 10% 25V
C94	1-164-346-11	CERAMIC CHIP	1μF 16V	C148	1-104-665-11	ELECT	100μF 20% 25V
C95	1-162-970-11	CERAMIC CHIP	0.01μF 10% 25V	C149	1-126-933-11	ELECT	100μF 20% 16V
C96	1-164-156-11	CERAMIC CHIP	0.1μF 25V	C150	1-164-156-11	CERAMIC CHIP	0.1μF 25V
C97	1-164-315-11	CERAMIC CHIP	470pF 5% 50V	C151	1-164-156-11	CERAMIC CHIP	0.1μF 25V
C98	1-126-960-11	ELECT	1μF 20% 50V	C301	1-162-970-11	CERAMIC CHIP	0.01μF 10% 25V
C99	1-165-176-11	CERAMIC CHIP	0.047μF 10% 16V	C302	1-125-837-91	CERAMIC CHIP	1μF 10% 6.3V
C101	1-162-960-11	CERAMIC CHIP	220pF 10% 50V	C303	1-107-826-11	CERAMIC CHIP	0.1μF 10% 16V



REF.NO.	PART NO.	DESCRIPTION	VALUES			REF.NO.	PART NO.	DESCRIPTION	VALUES		
C304	1-164-315-11	CERAMIC CHIP	470pF	5%	50V	C349	1-125-891-11	CERAMIC CHIP	0.47μF	10%	10V
C305	1-162-917-11	CERAMIC CHIP	15pF	5%	50V	C350	1-126-935-11	ELECT	470μF	20%	16V
C306	1-107-826-11	CERAMIC CHIP	0.1μF	10%	16V	C351	1-164-156-11	CERAMIC CHIP	0.1μF		25V
C307	1-164-156-11	CERAMIC CHIP	0.1μF		25V	C352	1-125-891-11	CERAMIC CHIP	0.47μF	10%	10V
C308	1-125-891-11	CERAMIC CHIP	0.47μF	10%	10V	C353	1-107-826-11	CERAMIC CHIP	0.1μF	10%	16V
C309	1-126-933-11	ELECT	100μF	20%	16V	C354	1-126-963-11	ELECT	4.7μF	20%	50V
C310	1-126-964-11	ELECT	10μF	20%	50V	C355	1-107-826-11	CERAMIC CHIP	0.1μF	10%	16V
C311	1-126-933-11	ELECT	100μF	20%	16V	C356	1-107-826-11	CERAMIC CHIP	0.1μF	10%	16V
C312	1-164-156-11	CERAMIC CHIP	0.1μF		25V	C357	1-162-970-11	CERAMIC CHIP	0.01μF	10%	25V
C313	1-164-156-11	CERAMIC CHIP	0.1μF		25V	C358	1-162-917-11	CERAMIC CHIP	15pF	5%	50V
C314	1-107-826-11	CERAMIC CHIP	0.1μF	10%	16V	C359	1-125-891-11	CERAMIC CHIP	0.47μF	10%	10V
C315	1-107-826-11	CERAMIC CHIP	0.1μF	10%	16V	C360	1-162-917-11	CERAMIC CHIP	15pF	5%	50V
C316	1-162-964-11	CERAMIC CHIP	0.001μF	10%	50V	C361	1-125-891-11	CERAMIC CHIP	0.47μF	10%	10V
C317	1-107-826-11	CERAMIC CHIP	0.1μF	10%	16V	C362	1-164-156-11	CERAMIC CHIP	0.1μF		25V
C318	1-164-156-11	CERAMIC CHIP	0.1μF		25V	C363	1-126-933-11	ELECT	100μF	20%	16V
C319	1-125-891-11	CERAMIC CHIP	0.47μF	10%	10V	C364	1-126-933-11	ELECT	100μF	20%	16V
C320	1-126-963-11	ELECT	4.7μF	20%	50V	C365	1-126-933-11	ELECT	100μF	20%	16V
C321	1-164-156-11	CERAMIC CHIP	0.1μF		25V	C366	1-125-891-11	CERAMIC CHIP	0.47μF	10%	10V
C322	1-126-933-11	ELECT	100μF	20%	16V	C367	1-125-837-91	CERAMIC CHIP	1μF	10%	6.3V
C323	1-164-156-11	CERAMIC CHIP	0.1μF		25V	C368	1-107-826-11	CERAMIC CHIP	0.1μF	10%	16V
C325	1-107-826-11	CERAMIC CHIP	0.1μF	10%	16V	C369	1-126-933-11	ELECT	100μF	20%	16V
C326	1-164-315-11	CERAMIC CHIP	470pF	5%	50V	C370	1-126-933-11	ELECT	100μF	20%	16V
C327	1-162-917-11	CERAMIC CHIP	15pF	5%	50V	C371	1-126-933-11	ELECT	100μF	20%	16V
C328	1-107-826-11	CERAMIC CHIP	0.1μF	10%	16V	C372	1-126-933-11	ELECT	100μF	20%	16V
C329	1-125-891-11	CERAMIC CHIP	0.47μF	10%	10V	C373	1-164-156-11	CERAMIC CHIP	0.1μF		25V
C330	1-162-970-11	CERAMIC CHIP	0.01μF	10%	25V	C374	1-126-933-11	ELECT	100μF	20%	16V
C331	1-164-156-11	CERAMIC CHIP	0.1μF		25V	C375	1-164-156-11	CERAMIC CHIP	0.1μF		25V
C332	1-126-964-11	ELECT	10μF	20%	50V	C376	1-125-891-11	CERAMIC CHIP	0.47μF	10%	10V
C333	1-125-891-11	CERAMIC CHIP	0.47μF	10%	10V	C377	1-164-156-11	CERAMIC CHIP	0.1μF		25V
C334	1-125-891-11	CERAMIC CHIP	0.47μF	10%	10V	C378	1-164-156-11	CERAMIC CHIP	0.1μF		25V
C335	1-126-933-11	ELECT	100μF	20%	16V	C379	1-164-156-11	CERAMIC CHIP	0.1μF		25V
C336	1-125-891-11	CERAMIC CHIP	0.47μF	10%	10V	C380	1-162-964-11	CERAMIC CHIP	0.001μF	10%	50V
C337	1-107-826-11	CERAMIC CHIP	0.1μF	10%	16V	C381	1-107-826-11	CERAMIC CHIP	0.1μF	10%	16V
C338	1-126-963-11	ELECT	4.7μF	20%	50V	C382	1-125-891-11	CERAMIC CHIP	0.47μF	10%	10V
C339	1-107-826-11	CERAMIC CHIP	0.1μF	10%	16V	C383	1-125-891-11	CERAMIC CHIP	0.47μF	10%	10V
C340	1-107-826-11	CERAMIC CHIP	0.1μF	10%	16V	C384	1-164-156-11	CERAMIC CHIP	0.1μF		25V
C341	1-162-968-11	CERAMIC CHIP	0.0047μF	10%	50V	C385	1-162-968-11	CERAMIC CHIP	0.0047μF	10%	50V
C342	1-162-970-11	CERAMIC CHIP	0.01μF	10%	25V	C386	1-164-156-11	CERAMIC CHIP	0.1μF		25V
C343	1-126-963-11	ELECT	4.7μF	20%	50V	C387	1-126-964-11	ELECT	10μF	20%	50V
C344	1-107-826-11	CERAMIC CHIP	0.1μF	10%	16V	C388	1-125-891-11	CERAMIC CHIP	0.47μF	10%	10V
C345	1-107-826-11	CERAMIC CHIP	0.1μF	10%	16V	C389	1-125-891-11	CERAMIC CHIP	0.47μF	10%	10V
C346	1-125-891-11	CERAMIC CHIP	0.47μF	10%	10V	C390	1-126-964-11	ELECT	10μF	20%	50V
C347	1-164-156-11	CERAMIC CHIP	0.1μF		25V	C391	1-164-156-11	CERAMIC CHIP	0.1μF		25V
C348	1-164-156-11	CERAMIC CHIP	0.1μF		25V	C392	1-125-891-11	CERAMIC CHIP	0.47μF	10%	10V



REF.NO.	PART NO.	DESCRIPTION	VALUES			REF.NO.	PART NO.	DESCRIPTION	VALUES		
C393	1-125-891-11	CERAMIC CHIP	0.47μF	10%	10V	C468	1-125-891-11	CERAMIC CHIP	0.47μF	10%	10V
C394	1-126-933-11	ELECT	100μF	20%	16V	C470	1-162-970-11	CERAMIC CHIP	0.01μF	10%	25V
C395	1-125-891-11	CERAMIC CHIP	0.47μF	10%	10V	C472	1-125-891-11	CERAMIC CHIP	0.47μF	10%	10V
C396	1-125-891-11	CERAMIC CHIP	0.47μF	10%	10V	C476	1-164-156-11	CERAMIC CHIP	0.1μF		25V
C397	1-125-891-11	CERAMIC CHIP	0.47μF	10%	10V	C477	1-127-760-11	CERAMIC CHIP	4.7μF	10%	6.3V
C398	1-164-156-11	CERAMIC CHIP	0.1μF		25V	C478	1-216-864-11	SHORT CHIP			
C399	1-162-917-11	CERAMIC CHIP	15pF	5%	50V	C479	1-162-923-11	CERAMIC CHIP	47pF	5%	50V
C400	1-126-933-11	ELECT	100μF	20%	16V	C480	1-107-826-11	CERAMIC CHIP	0.1μF	10%	16V
C401	1-162-917-11	CERAMIC CHIP	15pF	5%	50V	C481	1-107-826-11	CERAMIC CHIP	0.1μF	10%	16V
C402	1-164-156-11	CERAMIC CHIP	0.1μF		25V	C482	1-107-826-11	CERAMIC CHIP	0.1μF	10%	16V
C404	1-164-156-11	CERAMIC CHIP	0.1μF		25V	C483	1-162-968-11	CERAMIC CHIP	0.0047μF	10%	50V
C405	1-164-156-11	CERAMIC CHIP	0.1μF		25V	C484	1-164-156-11	CERAMIC CHIP	0.1μF		25V
C406	1-127-760-11	CERAMIC CHIP	4.7μF	10%	6.3V	C485	1-125-891-11	CERAMIC CHIP	0.47μF	10%	10V
C407	1-127-760-11	CERAMIC CHIP	4.7μF	10%	6.3V	C486	1-115-467-11	CERAMIC CHIP	0.22μF	10%	10V
C408	1-127-760-11	CERAMIC CHIP	4.7μF	10%	6.3V	C487	1-107-826-11	CERAMIC CHIP	0.1μF	10%	16V
C410	1-126-934-11	ELECT	220μF	20%	16V	C488	1-126-933-11	ELECT	100μF	20%	16V
C413	1-164-156-11	CERAMIC CHIP	0.1μF		25V	C489	1-125-891-11	CERAMIC CHIP	0.47μF	10%	10V
C414	1-162-970-11	CERAMIC CHIP	0.01μF	10%	25V	C490	1-164-156-11	CERAMIC CHIP	0.1μF		25V
C415	1-125-837-91	CERAMIC CHIP	1μF	10%	6.3V	C494	1-126-933-11	ELECT	100μF	20%	16V
C416	1-164-156-11	CERAMIC CHIP	0.1μF		25V	C495	1-164-156-11	CERAMIC CHIP	0.1μF		25V
C417	1-126-933-11	ELECT	100μF	20%	16V	C497	1-126-933-11	ELECT	100μF	20%	16V
C418	1-107-826-11	CERAMIC CHIP	0.1μF	10%	16V	C498	1-107-826-11	CERAMIC CHIP	0.1μF	10%	16V
C422	1-164-156-11	CERAMIC CHIP	0.1μF		25V	C500	1-164-816-11	CERAMIC CHIP	220pF	2.00%	50V
C423	1-164-156-11	CERAMIC CHIP	0.1μF		25V	C501	1-162-974-11	CERAMIC CHIP	0.01μF		50V
C426	1-164-156-11	CERAMIC CHIP	0.1μF		25V	C502	1-164-816-11	CERAMIC CHIP	220pF	2.00%	50V
C427	1-125-891-11	CERAMIC CHIP	0.47μF	10%	10V	C503	1-164-816-11	CERAMIC CHIP	220pF	2.00%	50V
C431	1-107-826-11	CERAMIC CHIP	0.1μF	10%	16V	C504	1-115-416-11	CERAMIC CHIP	0.001μF	5%	25V
C435	1-126-933-11	ELECT	100μF	20%	16V	C505	1-162-964-11	CERAMIC CHIP	0.001μF	10%	50V
C438	1-126-933-11	ELECT	100μF	20%	16V	C506	1-164-816-11	CERAMIC CHIP	220pF	2.00%	50V
C439	1-164-156-11	CERAMIC CHIP	0.1μF		25V	C507	1-162-966-11	CERAMIC CHIP	0.0022μF	10%	50V
C440	1-164-156-11	CERAMIC CHIP	0.1μF		25V	C701	1-164-156-11	CERAMIC CHIP	0.1μF		25V
C442	1-135-834-91	CERAMIC CHIP	2.2E+06pF		6.3V	C702	1-126-964-11	ELECT	10μF	20%	50V
C443	1-126-933-11	ELECT	100μF	20%	16V	C703	1-164-156-11	CERAMIC CHIP	0.1μF		25V
C444	1-110-563-11	CERAMIC CHIP	0.068μF	10%	16V	C704	1-126-947-11	ELECT	47μF	20%	35V
C449	1-125-837-91	CERAMIC CHIP	1μF	10%	6.3V	C705	1-164-156-11	CERAMIC CHIP	0.1μF		25V
C455	1-130-495-00	MYLAR	0.1μF	5%	50V	C706	1-164-156-11	CERAMIC CHIP	0.1μF		25V
C457	1-107-826-11	CERAMIC CHIP	0.1μF	10%	16V	C707	1-164-156-11	CERAMIC CHIP	0.1μF		25V
C458	1-136-244-11	FILM	0.1μF	2.00%	50V	C708	1-104-665-11	ELECT	100μF	20%	25V
C460	1-107-826-11	CERAMIC CHIP	0.1μF	10%	16V	C709	1-162-920-11	CERAMIC CHIP	27pF	5%	50V
C461	1-107-826-11	CERAMIC CHIP	0.1μF	10%	16V	C710	1-162-919-11	CERAMIC CHIP	22pF	5%	50V
C463	1-107-826-11	CERAMIC CHIP	0.1μF	10%	16V	C713	1-162-917-11	CERAMIC CHIP	15pF	5%	50V
C464	1-107-826-11	CERAMIC CHIP	0.1μF	10%	16V	C714	1-162-917-11	CERAMIC CHIP	15pF	5%	50V
C466	1-162-923-11	CERAMIC CHIP	47pF	5%	50V	C719	1-162-964-11	CERAMIC CHIP	0.001μF	10%	50V
C467	1-107-826-11	CERAMIC CHIP	0.1μF	10%	16V	C722	1-107-826-11	CERAMIC CHIP	0.1μF	10%	16V



REF.NO.	PART NO.	DESCRIPTION	VALUES			REF.NO.	PART NO.	DESCRIPTION	VALUES		
C728	1-126-933-11	ELECT	100μF	20%	16V	C798	1-165-908-11	CERAMIC CHIP	1μF	10%	10V
C730	1-162-915-11	CERAMIC CHIP	10pF	0.50pF	50V	C799	1-164-156-11	CERAMIC CHIP	0.1μF		25V
C731	1-162-927-11	CERAMIC CHIP	100pF	5%	50V	C800	1-162-970-11	CERAMIC CHIP	0.01μF	10%	25V
C732	1-162-927-11	CERAMIC CHIP	100pF	5%	50V	C801	1-107-826-11	CERAMIC CHIP	0.1μF	10%	16V
C733	1-115-416-11	CERAMIC CHIP	0.001μF	5%	25V	C802	1-126-935-11	ELECT	470μF	20%	16V
C739	1-126-963-11	ELECT	4.7μF	20%	50V	C803	1-126-933-11	ELECT	100μF	20%	16V
C740	1-126-963-11	ELECT	4.7μF	20%	50V	C804	1-165-908-11	CERAMIC CHIP	1μF	10%	10V
C741	1-126-963-11	ELECT	4.7μF	20%	50V	C805	1-165-908-11	CERAMIC CHIP	1μF	10%	10V
C744	1-126-935-11	ELECT	470μF	20%	16V	C806	1-165-908-11	CERAMIC CHIP	1μF	10%	10V
C745	1-164-156-11	CERAMIC CHIP	0.1μF		25V	C807	1-126-933-11	ELECT	100μF	20%	16V
C746	1-126-947-11	ELECT	47μF	20%	35V	C808	1-165-908-11	CERAMIC CHIP	1μF	10%	10V
C747	1-126-947-11	ELECT	47μF	20%	35V	C809	1-164-156-11	CERAMIC CHIP	0.1μF		25V
C749	1-126-947-11	ELECT	47μF	20%	35V	C810	1-126-947-11	ELECT	47μF	20%	35V
C751	1-126-943-11	ELECT	2200μF	20%	25V	C811	1-107-826-11	CERAMIC CHIP	0.1μF	10%	16V
C752	1-126-943-11	ELECT	2200μF	20%	25V						
C755	1-126-947-11	ELECT	47μF	20%	35V			CONNECTOR			
C757	1-130-495-00	MYLAR	0.1μF	5%	50V	* CN1	1-779-892-11	CONNECTOR, BOARD TO BOARD			10P
C758	1-126-947-11	ELECT	47μF	20%	35V	* CN2	1-779-892-11	CONNECTOR, BOARD TO BOARD			10P
C761	1-136-169-00	FILM	0.22μF	5%	50V	* CN3	1-779-892-11	CONNECTOR, BOARD TO BOARD			10P
C762	1-104-665-11	ELECT	100μF	20%	25V	* CN4	1-564-510-11	PLUG, CONNECTOR			7P
C763	1-136-153-00	FILM	0.01μF	5%	50V	CN5	1-573-979-22	CONNECTOR, BOARD TO BOARD			11P
C764	1-130-495-00	MYLAR	0.1μF	5%	50V	* CN6	1-793-922-11	CONNECTOR, DIN (RECEPTACLE)			64P
C765	1-136-153-00	FILM	0.01μF	5%	50V	* CN7	1-564-508-11	PLUG, CONNECTOR			5P
C767	1-136-287-11	FILM	0.0047μF	5%	100V	CN8	1-695-915-11	TAB (CONTACT)			
C771	1-130-495-00	MYLAR	0.1μF	5%	50V	* CN9	1-564-509-11	PLUG, CONNECTOR			6P
C772	1-130-495-00	MYLAR	0.1μF	5%	50V	* CN10	1-564-511-11	PLUG, CONNECTOR			8P
C773	1-164-227-11	CERAMIC CHIP	0.022μF	10%	25V	CN11	1-573-298-21	CONNECTOR, BOARD TO BOARD			20P
C774	1-136-287-11	FILM	0.0047μF	5%	100V	CN12	1-573-298-21	CONNECTOR, BOARD TO BOARD			20P
C775	1-136-169-00	FILM	0.22μF	5%	50V	* CN13	1-793-922-11	CONNECTOR, DIN (RECEPTACLE)			64P
C776	1-136-287-11	FILM	0.0047μF	5%	100V	* CN14	1-779-892-11	CONNECTOR, BOARD TO BOARD			10P
C780	1-104-665-11	ELECT	100μF	20%	25V	CN15	1-695-915-11	TAB (CONTACT)			
C784	1-137-367-11	MYLAR	0.0033μF	5%	50V	* CN16	1-564-506-11	PLUG, CONNECTOR			3P
C785	1-137-367-11	MYLAR	0.0033μF	5%	50V	* CN17	1-564-508-11	PLUG, CONNECTOR			5P
C786	1-136-159-00	FILM	0.033μF	5%	50V	* CN18	1-564-508-11	PLUG, CONNECTOR			5P
C787	1-136-159-00	FILM	0.033μF	5%	50V	* CN19	1-564-508-11	PLUG, CONNECTOR			5P
C788	1-137-365-11	MYLAR	0.0015μF	5%	50V	CN21	1-695-915-11	TAB (CONTACT)			
C790	1-137-365-11	MYLAR	0.0015μF	5%	50V	CN22	1-695-915-11	TAB (CONTACT)			
C791	1-136-169-00	FILM	0.22μF	5%	50V	* CN23	1-564-507-11	PLUG, CONNECTOR			4P
C792	1-136-169-00	FILM	0.22μF	5%	50V	* CN24	1-564-510-11	PLUG, CONNECTOR			7P
C793	1-128-934-91	CERAMIC CHIP	0.33μF	20%	10V	* CN701	1-564-507-11	PLUG, CONNECTOR			4P
C794	1-165-908-11	CERAMIC CHIP	1μF	10%	10V	* CN702	1-564-509-11	PLUG, CONNECTOR			6P
C795	1-165-908-11	CERAMIC CHIP	1μF	10%	10V	* CN703	1-564-509-11	PLUG, CONNECTOR			6P
C796	1-165-908-11	CERAMIC CHIP	1μF	10%	10V	* CN704	1-564-509-11	PLUG, CONNECTOR			6P
C797	1-165-908-11	CERAMIC CHIP	1μF	10%	10V	* CN705	1-564-507-11	PLUG, CONNECTOR			4P
						* CN706	1-564-507-11	PLUG, CONNECTOR			4P







REF.NO.	PART NO.	DESCRIPTION	VALUES	REF.NO.	PART NO.	DESCRIPTION	VALUES
DIODE				FILTER			
D1	8-719-404-50	DIODE	MA111-TX	FL4	1-239-848-21	FILTER, LOW PASS	
D5	8-719-083-87	DIODE	UDZS-TE17-33B	FL5	1-239-848-21	FILTER, LOW PASS	
D7	8-719-069-55	DIODE	UDZSTE-175.6B	FL6	1-239-848-21	FILTER, LOW PASS	
D307	8-719-978-33	DIODE	DTZ-TT11-6.8B	FL7	1-239-848-21	FILTER, LOW PASS	
D312	8-719-069-55	DIODE	UDZSTE-175.6B	IC			
D317	8-719-404-50	DIODE	MA111-TX	IC1	8-759-647-10	IC	UPC2933HF
D318	8-719-404-50	DIODE	MA111-TX	IC2	8-759-653-07	IC	PQ09RD21
D319	8-719-404-50	DIODE	MA111-TX	IC3	8-759-830-08	IC	NJM2068V-TE2
D321	8-719-404-50	DIODE	MA111-TX	IC4	8-759-569-92	IC	NJM2370U09-TE2
D701	8-719-404-50	DIODE	MA111-TX	IC5	8-759-100-96	IC	UPC4558G2
D702	8-719-404-50	DIODE	MA111-TX	IC6	6-700-960-01	IC	UPD64083GF-3BA
D703	8-719-083-57	DIODE	UDZSTE-173.6B	IC7	8-759-100-96	IC	UPC4558G2
D704	8-719-082-05	DIODE	M1MA142WKT1	IC8	8-759-647-10	IC	UPC2933HF
D705	8-719-083-87	DIODE	UDZS-TE17-33B	IC9	8-759-701-79	IC	NJM7812FA
D706	8-719-083-87	DIODE	UDZS-TE17-33B	IC10	8-759-100-96	IC	UPC4558G2
D708	8-719-404-50	DIODE	MA111-TX	IC11	8-759-100-96	IC	UPC4558G2
D709	8-719-404-50	DIODE	MA111-TX	IC12	6-700-898-01	IC	PQ05RD21
D710	8-719-082-05	DIODE	M1MA142WKT1	IC13	8-759-647-11	IC	UPC2905HF
D711	8-719-082-05	DIODE	M1MA142WKT1	IC14	6-700-399-01	IC	UPC2925T-E1
D712	8-719-082-05	DIODE	M1MA142WKT1	IC301	8-752-102-21	IC	CXA2103AQ
D713	8-719-082-05	DIODE	M1MA142WKT1	IC302	8-752-916-40	IC	CXP85840A-039Q
D714	8-719-404-50	DIODE	MA111-TX	IC303	8-752-102-21	IC	CXA2103AQ
D715	8-719-404-50	DIODE	MA111-TX	IC304	8-752-916-40	IC	CXP85840A-039Q
D716	8-719-404-50	DIODE	MA111-TX	IC305	8-759-595-97	IC	SN74LV4053ANSR
D718	8-719-404-50	DIODE	MA111-TX	IC306	8-752-103-44	IC	CXA2171Q
D719	8-719-404-50	DIODE	MA111-TX	IC307	8-759-595-97	IC	SN74LV4053ANSR
D720	8-719-920-67	DIODE	ERC91-02	IC309	8-752-100-25	IC	CXA2150AQ
D721	8-719-920-67	DIODE	ERC91-02	IC310	8-759-349-11	IC	PST9145NL
D723	8-719-083-85	DIODE	UDZS-TE17-22B	IC311	8-759-700-07	IC	NJM2903M
D724	8-719-083-85	DIODE	UDZS-TE17-22B	IC312	8-759-082-58	IC	TC7W08FU
D725	8-719-083-85	DIODE	UDZS-TE17-22B	IC701	8-759-349-11	IC	PST9145NL
D726	8-719-083-85	DIODE	UDZS-TE17-22B	IC702	6-700-149-01	IC	M24C04-MN6T(A)
D729	8-719-404-50	DIODE	MA111-TX	IC703	8-759-575-72	IC	M24C08-WMN6T
FERRITE BEAD				IC704	6-803-474-01	IC	M306V2ME-212FP
FB2	1-414-445-11	FERRITE	0μH	IC707	8-759-100-96	IC	UPC4558G2
FB3	1-414-445-11	FERRITE	0μH	IC708	8-759-190-89	IC	TDA7265
FB4	1-414-445-11	FERRITE	0μH	IC711	6-704-236-01	IC	NJW1148
FB5	1-216-295-91	SHORT CHIP		CHIP CONDUCTOR			
FB6	1-414-445-11	FERRITE	0μH	JR2	1-216-864-11	SHORT CHIP	

NOTE: The components identified by shading and  mark are critical for safety. Replace only with part number specified.

NOTE: Les composants identifiés par un trame et une  sont critiques pour la sécurité. Ne les remplacer que par une pièce portant le numéro spécifique.



REF.NO.	PART NO.	DESCRIPTION	VALUES	REF.NO.	PART NO.	DESCRIPTION	VALUES		
COIL				TRANSISTOR					
L1	1-412-948-11	INDUCTOR	5.6μH	Q1	8-729-424-02	TRANSISTOR	2SB709A-QRS-TX		
L2	1-469-555-21	INDUCTOR	10μH	Q2	8-729-424-02	TRANSISTOR	2SB709A-QRS-TX		
L3	1-469-555-21	INDUCTOR	10μH	Q3	8-729-422-27	TRANSISTOR	2SD601A-Q		
L4	1-469-555-21	INDUCTOR	10μH	Q4	8-729-424-02	TRANSISTOR	2SB709A-QRS-TX		
L5	1-469-555-21	INDUCTOR	10μH	Q5	8-729-422-27	TRANSISTOR	2SD601A-Q		
L6	1-469-555-21	INDUCTOR	10μH	Q6	8-729-422-27	TRANSISTOR	2SD601A-Q		
L7	1-414-856-11	INDUCTOR	10μH	Q7	8-729-424-02	TRANSISTOR	2SB709A-QRS-TX		
L8	1-414-856-11	INDUCTOR	10μH	Q8	8-729-424-02	TRANSISTOR	2SB709A-QRS-TX		
L9	1-414-856-11	INDUCTOR	10μH	Q11	8-729-422-27	TRANSISTOR	2SD601A-Q		
L10	1-412-537-31	INDUCTOR	100μH	Q12	8-729-424-02	TRANSISTOR	2SB709A-QRS-TX		
L11	1-414-856-11	INDUCTOR	10μH	Q13	8-729-424-02	TRANSISTOR	2SB709A-QRS-TX		
L12	1-414-856-11	INDUCTOR	10μH	Q14	8-729-422-27	TRANSISTOR	2SD601A-Q		
L13	1-414-856-11	INDUCTOR	10μH	Q15	8-729-424-02	TRANSISTOR	2SB709A-QRS-TX		
L301	1-469-555-21	INDUCTOR	10μH	Q16	8-729-424-02	TRANSISTOR	2SB709A-QRS-TX		
L302	1-469-555-21	INDUCTOR	10μH	Q17	8-729-422-27	TRANSISTOR	2SD601A-Q		
L303	1-469-555-21	INDUCTOR	10μH	Q18	8-729-422-27	TRANSISTOR	2SD601A-Q		
L304	1-469-555-21	INDUCTOR	10μH	Q19	8-729-422-27	TRANSISTOR	2SD601A-Q		
L305	1-469-555-21	INDUCTOR	10μH	Q20	8-729-422-27	TRANSISTOR	2SD601A-Q		
L306	1-414-193-41	INDUCTOR	220μH	Q21	8-729-424-02	TRANSISTOR	2SB709A-QRS-TX		
L307	1-469-555-21	INDUCTOR	10μH	Q22	8-729-422-27	TRANSISTOR	2SD601A-Q		
L308	1-414-856-11	INDUCTOR	10μH	Q23	8-729-422-27	TRANSISTOR	2SD601A-Q		
L309	1-469-555-21	INDUCTOR	10μH	Q24	8-729-422-27	TRANSISTOR	2SD601A-Q		
L310	1-469-555-21	INDUCTOR	10μH	Q25	8-729-422-27	TRANSISTOR	2SD601A-Q		
L311	1-469-555-21	INDUCTOR	10μH	Q26	8-729-422-27	TRANSISTOR	2SD601A-Q		
L312	1-469-555-21	INDUCTOR	10μH	Q27	8-729-422-27	TRANSISTOR	2SD601A-Q		
L313	1-414-856-11	INDUCTOR	10μH	Q28	8-729-424-02	TRANSISTOR	2SB709A-QRS-TX		
L315	1-469-555-21	INDUCTOR	10μH	Q30	1-801-806-11	TRANSISTOR	DTC144EKA		
L316	1-414-856-11	INDUCTOR	10μH	Q301	8-729-422-27	TRANSISTOR	2SD601A-Q		
L317	1-414-856-11	INDUCTOR	10μH	Q304	8-729-422-27	TRANSISTOR	2SD601A-Q		
L318	1-469-555-21	INDUCTOR	10μH	Q306	8-729-422-27	TRANSISTOR	2SD601A-Q		
L321	1-414-856-11	INDUCTOR	10μH	Q307	8-729-422-27	TRANSISTOR	2SD601A-Q		
L701	1-414-179-21	INDUCTOR	2.2μH	Q308	8-729-424-02	TRANSISTOR	2SB709A-QRS-TX		
L702	1-412-911-11	FERRITE	0μH	Q309	8-729-422-27	TRANSISTOR	2SD601A-Q		
IC LINK				Q310	8-729-422-27	TRANSISTOR	2SD601A-Q		
	PS1	1-532-679-00	IC LINK	0.6A	50V	Q311	8-729-422-27	TRANSISTOR	2SD601A-Q
	PS2	1-532-685-00	IC LINK	0.8A	50V	Q312	8-729-424-02	TRANSISTOR	2SB709A-QRS-TX
	PS3	1-532-679-00	IC LINK	0.6A	50V	Q313	8-729-422-27	TRANSISTOR	2SD601A-Q
	PS701	1-576-336-21	IC LINK	2A	50V	Q314	8-729-422-27	TRANSISTOR	2SD601A-Q
	PS702	1-576-336-21	IC LINK	2A	50V	Q315	8-729-422-27	TRANSISTOR	2SD601A-Q
						Q316	8-729-422-27	TRANSISTOR	2SD601A-Q
						Q317	8-729-422-27	TRANSISTOR	2SD601A-Q
						Q318	8-729-422-27	TRANSISTOR	2SD601A-Q



REF.NO.	PART NO.	DESCRIPTION	VALUES	REF.NO.	PART NO.	DESCRIPTION	VALUES
Q319	8-729-422-27	TRANSISTOR	2SD601A-Q	Q367	8-729-122-63	TRANSISTOR	2SA1226-E4
Q320	8-729-422-27	TRANSISTOR	2SD601A-Q	Q368	8-729-422-27	TRANSISTOR	2SD601A-Q
Q321	8-729-422-27	TRANSISTOR	2SD601A-Q	Q369	1-801-806-11	TRANSISTOR	DTC144EKA
Q322	8-729-422-27	TRANSISTOR	2SD601A-Q	Q373	8-729-422-27	TRANSISTOR	2SD601A-Q
Q323	8-729-422-27	TRANSISTOR	2SD601A-Q	Q374	8-729-422-27	TRANSISTOR	2SD601A-Q
Q324	8-729-422-27	TRANSISTOR	2SD601A-Q	Q378	8-729-422-27	TRANSISTOR	2SD601A-Q
Q325	8-729-424-02	TRANSISTOR	2SB709A-QRS-TX	Q379	8-729-424-02	TRANSISTOR	2SB709A-QRS-TX
Q326	8-729-424-02	TRANSISTOR	2SB709A-QRS-TX	Q380	8-729-422-27	TRANSISTOR	2SD601A-Q
Q327	8-729-424-02	TRANSISTOR	2SB709A-QRS-TX	Q381	8-729-422-27	TRANSISTOR	2SD601A-Q
Q328	8-729-424-02	TRANSISTOR	2SB709A-QRS-TX	Q501	8-729-026-49	TRANSISTOR	2SA1037AK-T146-R
Q329	8-729-424-02	TRANSISTOR	2SB709A-QRS-TX	Q502	1-801-806-11	TRANSISTOR	DTC144EKA
Q330	8-729-424-02	TRANSISTOR	2SB709A-QRS-TX	Q701	8-729-422-27	TRANSISTOR	2SD601A-Q
Q331	8-729-424-02	TRANSISTOR	2SB709A-QRS-TX	Q702	8-729-424-02	TRANSISTOR	2SB709A-QRS-TX
Q332	8-729-424-02	TRANSISTOR	2SB709A-QRS-TX	Q703	8-729-422-27	TRANSISTOR	2SD601A-Q
Q333	8-729-424-02	TRANSISTOR	2SB709A-QRS-TX	Q704	8-729-424-02	TRANSISTOR	2SB709A-QRS-TX
Q334	8-729-424-02	TRANSISTOR	2SB709A-QRS-TX	Q705	8-729-422-27	TRANSISTOR	2SD601A-Q
Q335	8-729-422-27	TRANSISTOR	2SD601A-Q	Q706	8-729-424-02	TRANSISTOR	2SB709A-QRS-TX
Q336	8-729-422-27	TRANSISTOR	2SD601A-Q	Q707	1-801-806-11	TRANSISTOR	DTC144EKA
Q337	8-729-422-27	TRANSISTOR	2SD601A-Q	Q708	8-729-422-27	TRANSISTOR	2SD601A-Q
Q338	8-729-422-27	TRANSISTOR	2SD601A-Q	Q709	8-729-422-27	TRANSISTOR	2SD601A-Q
Q339	8-729-422-27	TRANSISTOR	2SD601A-Q	Q710	8-729-422-27	TRANSISTOR	2SD601A-Q
Q340	8-729-422-27	TRANSISTOR	2SD601A-Q	Q712	8-729-424-02	TRANSISTOR	2SB709A-QRS-TX
Q342	8-729-422-27	TRANSISTOR	2SD601A-Q	Q713	8-729-424-02	TRANSISTOR	2SB709A-QRS-TX
Q343	8-729-122-63	TRANSISTOR	2SA1226-E4	Q714	8-729-027-38	TRANSISTOR	DTA144EKA-T146
Q344	8-729-424-02	TRANSISTOR	2SB709A-QRS-TX	Q715	8-729-422-27	TRANSISTOR	2SD601A-Q
Q345	8-729-424-02	TRANSISTOR	2SB709A-QRS-TX	Q716	8-729-422-27	TRANSISTOR	2SD601A-Q
Q346	8-729-422-27	TRANSISTOR	2SD601A-Q	Q717	8-729-422-27	TRANSISTOR	2SD601A-Q
Q347	8-729-122-63	TRANSISTOR	2SA1226-E4	Q718	8-729-422-27	TRANSISTOR	2SD601A-Q
Q348	8-729-424-02	TRANSISTOR	2SB709A-QRS-TX	Q719	8-729-424-02	TRANSISTOR	2SB709A-QRS-TX
Q349	8-729-422-27	TRANSISTOR	2SD601A-Q	Q721	8-729-424-02	TRANSISTOR	2SB709A-QRS-TX
Q350	8-729-422-27	TRANSISTOR	2SD601A-Q	Q722	8-729-422-27	TRANSISTOR	2SD601A-Q
Q351	8-729-122-63	TRANSISTOR	2SA1226-E4	Q723	8-729-422-27	TRANSISTOR	2SD601A-Q
Q352	8-729-422-27	TRANSISTOR	2SD601A-Q	Q725	8-729-424-02	TRANSISTOR	2SB709A-QRS-TX
Q353	8-729-424-02	TRANSISTOR	2SB709A-QRS-TX	RESISTOR			
Q354	8-729-424-02	TRANSISTOR	2SB709A-QRS-TX	R1	1-216-464-11	METAL OXIDE	18K 5% 2W
Q355	8-729-422-27	TRANSISTOR	2SD601A-Q	R2	1-216-813-11	METAL CHIP	220 5% 1/10W
Q356	8-729-424-02	TRANSISTOR	2SB709A-QRS-TX	R3	1-216-813-11	METAL CHIP	220 5% 1/10W
Q357	8-729-424-02	TRANSISTOR	2SB709A-QRS-TX	R4	1-216-813-11	METAL CHIP	220 5% 1/10W
Q358	8-729-424-02	TRANSISTOR	2SB709A-QRS-TX	R5	1-216-813-11	METAL CHIP	220 5% 1/10W
Q359	8-729-422-27	TRANSISTOR	2SD601A-Q	R6	1-216-813-11	METAL CHIP	220 5% 1/10W
Q360	8-729-424-02	TRANSISTOR	2SB709A-QRS-TX	R7	1-216-833-11	METAL CHIP	10K 5% 1/10W
Q361	8-729-422-27	TRANSISTOR	2SD601A-Q	R8	1-216-813-11	METAL CHIP	220 5% 1/10W
Q362	8-729-422-27	TRANSISTOR	2SD601A-Q	R9	1-216-813-11	METAL CHIP	220 5% 1/10W
Q363	8-729-422-27	TRANSISTOR	2SD601A-Q				



REF.NO.	PART NO.	DESCRIPTION	VALUES			REF.NO.	PART NO.	DESCRIPTION	VALUES		
R10	1-216-829-11	METAL CHIP	4.7K	5%	1/10W	R70	1-216-845-11	METAL CHIP	100K	5%	1/10W
R11	1-218-720-11	METAL CHIP	15K	0.50%	1/10W	R71	1-216-813-11	METAL CHIP	220	5%	1/10W
R12	1-218-722-11	METAL CHIP	18K	0.50%	1/10W	R72	1-216-821-11	METAL CHIP	1K	5%	1/10W
R13	1-218-740-11	METAL CHIP	100K	0.50%	1/10W	R73	1-218-686-11	METAL CHIP	560	0.50%	1/10W
R14	1-216-845-11	METAL CHIP	100K	5%	1/10W	R74	1-218-684-11	METAL CHIP	470	0.50%	1/10W
R16	1-218-702-11	METAL CHIP	2.7K	0.50%	1/10W	R75	1-216-829-11	METAL CHIP	4.7K	5%	1/10W
R17	1-218-706-11	METAL CHIP	3.9K	0.50%	1/10W	R76	1-216-818-11	METAL CHIP	560	5%	1/10W
R18	1-218-714-11	METAL CHIP	8.2K	0.50%	1/10W	R77	1-216-821-11	METAL CHIP	1K	5%	1/10W
R19	1-216-816-11	METAL CHIP	390	5%	1/10W	R78	1-218-680-11	METAL CHIP	330	0.50%	1/10W
R20	1-216-827-11	METAL CHIP	3.3K	5%	1/10W	R79	1-216-818-11	METAL CHIP	560	5%	1/10W
R21	1-216-839-11	METAL CHIP	33K	5%	1/10W	R80	1-218-684-11	METAL CHIP	470	0.50%	1/10W
R22	1-216-813-11	METAL CHIP	220	5%	1/10W	R81	1-216-825-11	METAL CHIP	2.2K	5%	1/10W
R23	1-216-864-11	SHORT CHIP				R82	1-216-821-11	METAL CHIP	1K	5%	1/10W
R27	1-218-707-11	METAL CHIP	4.3K	0.50%	1/10W	R85	1-216-830-11	METAL CHIP	5.6K	5%	1/10W
R30	1-216-809-11	METAL CHIP	100	5%	1/10W	R87	1-216-833-11	METAL CHIP	10K	5%	1/10W
R31	1-216-809-11	METAL CHIP	100	5%	1/10W	R88	1-216-830-11	METAL CHIP	5.6K	5%	1/10W
R33	1-216-809-11	METAL CHIP	100	5%	1/10W	R89	1-216-813-11	METAL CHIP	220	5%	1/10W
R37	1-216-853-11	METAL CHIP	470K	5%	1/10W	R90	1-216-864-11	SHORT CHIP			
R39	1-216-855-11	METAL CHIP	680K	5%	1/10W	R91	1-216-864-11	SHORT CHIP			
R42	1-216-855-11	METAL CHIP	680K	5%	1/10W	R92	1-216-830-11	METAL CHIP	5.6K	5%	1/10W
R43	1-216-853-11	METAL CHIP	470K	5%	1/10W	R93	1-216-830-11	METAL CHIP	5.6K	5%	1/10W
R44	1-249-377-11	CARBON	0.47	5%	1/4W	R95	1-216-818-11	METAL CHIP	560	5%	1/10W
R46	1-216-822-11	METAL CHIP	1.2K	5%	1/10W	R96	1-216-818-11	METAL CHIP	560	5%	1/10W
R48	1-216-809-11	METAL CHIP	100	5%	1/10W	R99	1-216-825-11	METAL CHIP	2.2K	5%	1/10W
R49	1-216-829-11	METAL CHIP	4.7K	5%	1/10W	R100	1-216-833-11	METAL CHIP	10K	5%	1/10W
R50	1-216-809-11	METAL CHIP	100	5%	1/10W	R102	1-216-821-11	METAL CHIP	1K	5%	1/10W
R51	1-216-833-11	METAL CHIP	10K	5%	1/10W	R103	1-216-825-11	METAL CHIP	2.2K	5%	1/10W
R52	1-216-833-11	METAL CHIP	10K	5%	1/10W	R104	1-216-821-11	METAL CHIP	1K	5%	1/10W
R53	1-216-817-11	METAL CHIP	470	5%	1/10W	R105	1-216-821-11	METAL CHIP	1K	5%	1/10W
R54	1-216-817-11	METAL CHIP	470	5%	1/10W	R106	1-216-809-11	METAL CHIP	100	5%	1/10W
R55	1-216-822-11	METAL CHIP	1.2K	5%	1/10W	R107	1-216-833-11	METAL CHIP	10K	5%	1/10W
R56	1-216-805-11	METAL CHIP	47	5%	1/10W	R108	1-216-822-11	METAL CHIP	1.2K	5%	1/10W
R57	1-216-805-11	METAL CHIP	47	5%	1/10W	R109	1-216-816-11	METAL CHIP	390	5%	1/10W
R59	1-216-821-11	METAL CHIP	1K	5%	1/10W	R110	1-216-809-11	METAL CHIP	100	5%	1/10W
R60	1-216-833-11	METAL CHIP	10K	5%	1/10W	R111	1-216-809-11	METAL CHIP	100	5%	1/10W
R61	1-216-825-11	METAL CHIP	2.2K	5%	1/10W	R112	1-216-857-11	METAL CHIP	1M	5%	1/10W
R62	1-216-821-11	METAL CHIP	1K	5%	1/10W	R113	1-216-845-11	METAL CHIP	100K	5%	1/10W
R63	1-216-809-11	METAL CHIP	100	5%	1/10W	R114	1-216-809-11	METAL CHIP	100	5%	1/10W
R64	1-216-837-11	METAL CHIP	22K	5%	1/10W	R115	1-216-820-11	METAL CHIP	820	5%	1/10W
R65	1-216-833-11	METAL CHIP	10K	5%	1/10W	R116	1-216-825-11	METAL CHIP	2.2K	5%	1/10W
R66	1-216-849-11	METAL CHIP	220K	5%	1/10W	R117	1-216-821-11	METAL CHIP	1K	5%	1/10W
R67	1-216-841-11	METAL CHIP	47K	5%	1/10W	R118	1-216-820-11	METAL CHIP	820	5%	1/10W
R68	1-216-839-11	METAL CHIP	33K	5%	1/10W	R119	1-216-825-11	METAL CHIP	2.2K	5%	1/10W
R69	1-216-857-11	METAL CHIP	1M	5%	1/10W	R120	1-216-834-11	METAL CHIP	12K	5%	1/10W



REF.NO.	PART NO.	DESCRIPTION	VALUES			REF.NO.	PART NO.	DESCRIPTION	VALUES		
R121	1-216-839-11	METAL CHIP	33K	5%	1/10W	R319	1-216-864-11	SHORT CHIP			
R122	1-216-822-11	METAL CHIP	1.2K	5%	1/10W	R320	1-216-833-11	METAL CHIP	10K	5%	1/10W
R123	1-216-833-11	METAL CHIP	10K	5%	1/10W	R321	1-216-821-11	METAL CHIP	1K	5%	1/10W
R124	1-216-834-11	METAL CHIP	12K	5%	1/10W	R322	1-216-809-11	METAL CHIP	100	5%	1/10W
R125	1-216-839-11	METAL CHIP	33K	5%	1/10W	R323	1-216-809-11	METAL CHIP	100	5%	1/10W
R126	1-216-825-11	METAL CHIP	2.2K	5%	1/10W	R324	1-216-809-11	METAL CHIP	100	5%	1/10W
R127	1-216-839-11	METAL CHIP	33K	5%	1/10W	R325	1-216-835-11	METAL CHIP	15K	5%	1/10W
R128	1-216-821-11	METAL CHIP	1K	5%	1/10W	R326	1-216-864-11	SHORT CHIP			
R129	1-216-805-11	METAL CHIP	47	5%	1/10W	R327	1-216-817-11	METAL CHIP	470	5%	1/10W
R130	1-216-821-11	METAL CHIP	1K	5%	1/10W	R329	1-216-829-11	METAL CHIP	4.7K	5%	1/10W
R131	1-216-837-11	METAL CHIP	22K	5%	1/10W	R330	1-216-828-11	METAL CHIP	3.9K	5%	1/10W
R133	1-218-686-11	METAL CHIP	560	0.50%	1/10W	R331	1-216-833-11	METAL CHIP	10K	5%	1/10W
R134	1-218-683-11	METAL CHIP	430	0.50%	1/10W	R332	1-218-700-11	METAL CHIP	2.2K	0.50%	1/10W
R135	1-216-809-11	METAL CHIP	100	5%	1/10W	R333	1-216-809-11	METAL CHIP	100	5%	1/10W
R136	1-216-821-11	METAL CHIP	1K	5%	1/10W	R334	1-216-809-11	METAL CHIP	100	5%	1/10W
R137	1-216-833-11	METAL CHIP	10K	5%	1/10W	R335	1-216-829-11	METAL CHIP	4.7K	5%	1/10W
R138	1-216-833-11	METAL CHIP	10K	5%	1/10W	R336	1-216-809-11	METAL CHIP	100	5%	1/10W
R139	1-216-841-11	METAL CHIP	47K	5%	1/10W	R337	1-216-823-11	METAL CHIP	1.5K	5%	1/10W
R140	1-216-833-11	METAL CHIP	10K	5%	1/10W	R338	1-216-823-11	METAL CHIP	1.5K	5%	1/10W
R141	1-216-809-11	METAL CHIP	100	5%	1/10W	R339	1-216-809-11	METAL CHIP	100	5%	1/10W
R142	1-216-843-11	METAL CHIP	68K	5%	1/10W	R340	1-216-828-11	METAL CHIP	3.9K	5%	1/10W
R143	1-216-829-11	METAL CHIP	4.7K	5%	1/10W	R341	1-218-706-11	METAL CHIP	3.9K	0.50%	1/10W
R144	1-216-843-11	METAL CHIP	68K	5%	1/10W	R342	1-216-841-11	METAL CHIP	47K	5%	1/10W
R145	1-216-829-11	METAL CHIP	4.7K	5%	1/10W	R343	1-216-809-11	METAL CHIP	100	5%	1/10W
R146	1-216-845-11	METAL CHIP	100K	5%	1/10W	R344	1-216-809-11	METAL CHIP	100	5%	1/10W
R147	1-216-833-11	METAL CHIP	10K	5%	1/10W	R345	1-218-696-11	METAL CHIP	1.5K	0.50%	1/10W
R148	1-216-397-11	METAL OXIDE	4.7	5%	3W	R346	1-218-696-11	METAL CHIP	1.5K	0.50%	1/10W
R151	1-216-833-11	METAL CHIP	10K	5%	1/10W	R347	1-216-817-11	METAL CHIP	470	5%	1/10W
R152	1-216-833-11	METAL CHIP	10K	5%	1/10W	R348	1-216-841-11	METAL CHIP	47K	5%	1/10W
R153	1-216-833-11	METAL CHIP	10K	5%	1/10W	R349	1-216-813-11	METAL CHIP	220	5%	1/10W
R154	1-216-830-11	METAL CHIP	5.6K	5%	1/10W	R350	1-216-809-11	METAL CHIP	100	5%	1/10W
R155	1-216-864-11	SHORT CHIP				R351	1-216-813-11	METAL CHIP	220	5%	1/10W
R301	1-216-809-11	METAL CHIP	100	5%	1/10W	R352	1-216-813-11	METAL CHIP	220	5%	1/10W
R302	1-216-805-11	METAL CHIP	47	5%	1/10W	R353	1-216-809-11	METAL CHIP	100	5%	1/10W
R303	1-216-833-11	METAL CHIP	10K	5%	1/10W	R354	1-216-829-11	METAL CHIP	4.7K	5%	1/10W
R304	1-216-833-11	METAL CHIP	10K	5%	1/10W	R355	1-216-809-11	METAL CHIP	100	5%	1/10W
R305	1-216-835-11	METAL CHIP	15K	5%	1/10W	R356	1-216-841-11	METAL CHIP	47K	5%	1/10W
R308	1-216-821-11	METAL CHIP	1K	5%	1/10W	R357	1-216-837-11	METAL CHIP	22K	5%	1/10W
R309	1-216-813-11	METAL CHIP	220	5%	1/10W	R358	1-216-837-11	METAL CHIP	22K	5%	1/10W
R310	1-216-857-11	METAL CHIP	1M	5%	1/10W	R359	1-216-837-11	METAL CHIP	22K	5%	1/10W
R311	1-216-840-11	METAL CHIP	39K	5%	1/10W	R360	1-216-837-11	METAL CHIP	22K	5%	1/10W
R313	1-216-833-11	METAL CHIP	10K	5%	1/10W	R361	1-216-837-11	METAL CHIP	22K	5%	1/10W
R314	1-216-833-11	METAL CHIP	10K	5%	1/10W	R362	1-216-837-11	METAL CHIP	22K	5%	1/10W
R318	1-216-833-11	METAL CHIP	10K	5%	1/10W	R363	1-216-809-11	METAL CHIP	100	5%	1/10W



REF.NO.	PART NO.	DESCRIPTION	VALUES			REF.NO.	PART NO.	DESCRIPTION	VALUES		
R364	1-216-809-11	METAL CHIP	100	5%	1/10W	R408	1-216-821-11	METAL CHIP	1K	5%	1/10W
R365	1-216-809-11	METAL CHIP	100	5%	1/10W	R409	1-216-821-11	METAL CHIP	1K	5%	1/10W
R366	1-216-841-11	METAL CHIP	47K	5%	1/10W	R410	1-218-673-11	METAL CHIP	160	0.50%	1/10W
R367	1-216-821-11	METAL CHIP	1K	5%	1/10W	R411	1-218-673-11	METAL CHIP	160	0.50%	1/10W
R368	1-216-821-11	METAL CHIP	1K	5%	1/10W	R412	1-216-813-11	METAL CHIP	220	5%	1/10W
R369	1-216-821-11	METAL CHIP	1K	5%	1/10W	R413	1-218-668-11	METAL CHIP	100	0.50%	1/10W
R370	1-216-825-11	METAL CHIP	2.2K	5%	1/10W	R414	1-218-668-11	METAL CHIP	100	0.50%	1/10W
R371	1-216-825-11	METAL CHIP	2.2K	5%	1/10W	R415	1-218-668-11	METAL CHIP	100	0.50%	1/10W
R372	1-216-825-11	METAL CHIP	2.2K	5%	1/10W	R416	1-216-857-11	METAL CHIP	1M	5%	1/10W
R373	1-216-809-11	METAL CHIP	100	5%	1/10W	R417	1-216-809-11	METAL CHIP	100	5%	1/10W
R374	1-216-815-11	METAL CHIP	330	5%	1/10W	R418	1-216-809-11	METAL CHIP	100	5%	1/10W
R375	1-216-815-11	METAL CHIP	330	5%	1/10W	R419	1-218-702-11	METAL CHIP	2.7K	0.50%	1/10W
R376	1-216-815-11	METAL CHIP	330	5%	1/10W	R420	1-218-698-11	METAL CHIP	1.8K	0.50%	1/10W
R377	1-216-837-11	METAL CHIP	22K	5%	1/10W	R421	1-216-809-11	METAL CHIP	100	5%	1/10W
R378	1-216-837-11	METAL CHIP	22K	5%	1/10W	R422	1-216-809-11	METAL CHIP	100	5%	1/10W
R379	1-216-837-11	METAL CHIP	22K	5%	1/10W	R423	1-216-809-11	METAL CHIP	100	5%	1/10W
R380	1-216-837-11	METAL CHIP	22K	5%	1/10W	R424	1-218-674-11	METAL CHIP	180	0.50%	1/10W
R381	1-216-837-11	METAL CHIP	22K	5%	1/10W	R425	1-218-674-11	METAL CHIP	180	0.50%	1/10W
R382	1-216-837-11	METAL CHIP	22K	5%	1/10W	R426	1-218-674-11	METAL CHIP	180	0.50%	1/10W
R383	1-216-809-11	METAL CHIP	100	5%	1/10W	R427	1-218-673-11	METAL CHIP	160	0.50%	1/10W
R384	1-216-809-11	METAL CHIP	100	5%	1/10W	R428	1-216-864-11	SHORT CHIP			
R385	1-216-821-11	METAL CHIP	1K	5%	1/10W	R429	1-216-850-11	METAL CHIP	270K	5%	1/10W
R386	1-216-809-11	METAL CHIP	100	5%	1/10W	R431	1-216-809-11	METAL CHIP	100	5%	1/10W
R387	1-216-845-11	METAL CHIP	100K	5%	1/10W	R432	1-216-817-11	METAL CHIP	470	5%	1/10W
R388	1-216-837-11	METAL CHIP	22K	5%	1/10W	R433	1-216-817-11	METAL CHIP	470	5%	1/10W
R389	1-216-809-11	METAL CHIP	100	5%	1/10W	R434	1-216-809-11	METAL CHIP	100	5%	1/10W
R390	1-216-809-11	METAL CHIP	100	5%	1/10W	R435	1-216-817-11	METAL CHIP	470	5%	1/10W
R391	1-216-809-11	METAL CHIP	100	5%	1/10W	R436	1-216-809-11	METAL CHIP	100	5%	1/10W
R392	1-216-809-11	METAL CHIP	100	5%	1/10W	R437	1-216-809-11	METAL CHIP	100	5%	1/10W
R393	1-216-809-11	METAL CHIP	100	5%	1/10W	R438	1-216-809-11	METAL CHIP	100	5%	1/10W
R394	1-216-809-11	METAL CHIP	100	5%	1/10W	R439	1-216-817-11	METAL CHIP	470	5%	1/10W
R395	1-216-821-11	METAL CHIP	1K	5%	1/10W	R440	1-216-813-11	METAL CHIP	220	5%	1/10W
R396	1-216-821-11	METAL CHIP	1K	5%	1/10W	R441	1-216-813-11	METAL CHIP	220	5%	1/10W
R397	1-216-821-11	METAL CHIP	1K	5%	1/10W	R442	1-216-813-11	METAL CHIP	220	5%	1/10W
R398	1-216-845-11	METAL CHIP	100K	5%	1/10W	R443	1-216-809-11	METAL CHIP	100	5%	1/10W
R399	1-216-833-11	METAL CHIP	10K	5%	1/10W	R444	1-216-809-11	METAL CHIP	100	5%	1/10W
R400	1-216-845-11	METAL CHIP	100K	5%	1/10W	R445	1-216-809-11	METAL CHIP	100	5%	1/10W
R401	1-216-845-11	METAL CHIP	100K	5%	1/10W	R446	1-216-809-11	METAL CHIP	100	5%	1/10W
R402	1-216-845-11	METAL CHIP	100K	5%	1/10W	R448	1-216-809-11	METAL CHIP	100	5%	1/10W
R403	1-216-845-11	METAL CHIP	100K	5%	1/10W	R449	1-216-809-11	METAL CHIP	100	5%	1/10W
R404	1-216-845-11	METAL CHIP	100K	5%	1/10W	R450	1-216-814-11	METAL CHIP	270	5%	1/10W
R405	1-216-845-11	METAL CHIP	100K	5%	1/10W	R451	1-216-814-11	METAL CHIP	270	5%	1/10W
R406	1-216-864-11	SHORT CHIP				R452	1-216-814-11	METAL CHIP	270	5%	1/10W
R407	1-216-833-11	METAL CHIP	10K	5%	1/10W	R456	1-216-825-11	METAL CHIP	2.2K	5%	1/10W



REF.NO.	PART NO.	DESCRIPTION	VALUES			REF.NO.	PART NO.	DESCRIPTION	VALUES		
R457	1-216-825-11	METAL CHIP	2.2K	5%	1/10W	R540	1-216-809-11	METAL CHIP	100	5%	1/10W
R458	1-216-825-11	METAL CHIP	2.2K	5%	1/10W	R541	1-218-867-11	METAL CHIP	6.8K	0.50%	1/10W
R459	1-216-815-11	METAL CHIP	330	5%	1/10W	R542	1-216-809-11	METAL CHIP	100	5%	1/10W
R460	1-216-815-11	METAL CHIP	330	5%	1/10W	R543	1-216-826-11	METAL CHIP	2.7K	5%	1/10W
R461	1-216-815-11	METAL CHIP	330	5%	1/10W	R544	1-216-827-11	METAL CHIP	3.3K	5%	1/10W
R463	1-218-716-11	METAL CHIP	10K	0.50%	1/10W	R550	1-216-863-11	METAL CHIP	3.3M	5%	1/10W
R466	1-216-841-11	METAL CHIP	47K	5%	1/10W	R551	1-216-833-11	METAL CHIP	10K	5%	1/10W
R467	1-216-841-11	METAL CHIP	47K	5%	1/10W	R552	1-216-809-11	METAL CHIP	100	5%	1/10W
R471	1-216-821-11	METAL CHIP	1K	5%	1/10W	R553	1-216-834-11	METAL CHIP	12K	5%	1/10W
R472	1-216-829-11	METAL CHIP	4.7K	5%	1/10W	R554	1-216-809-11	METAL CHIP	100	5%	1/10W
R473	1-216-809-11	METAL CHIP	100	5%	1/10W	R556	1-216-808-11	METAL CHIP	82	5%	1/10W
R474	1-216-833-11	METAL CHIP	10K	5%	1/10W	R557	1-216-808-11	METAL CHIP	82	5%	1/10W
R476	1-216-808-11	METAL CHIP	82	5%	1/10W	R558	1-216-808-11	METAL CHIP	82	5%	1/10W
R477	1-216-829-11	METAL CHIP	4.7K	5%	1/10W	R559	1-216-817-11	METAL CHIP	470	5%	1/10W
R480	1-216-829-11	METAL CHIP	4.7K	5%	1/10W	R561	1-216-829-11	METAL CHIP	4.7K	5%	1/10W
R481	1-216-821-11	METAL CHIP	1K	5%	1/10W	R562	1-216-817-11	METAL CHIP	470	5%	1/10W
R482	1-216-839-11	METAL CHIP	33K	5%	1/10W	R563	1-216-853-11	METAL CHIP	470K	5%	1/10W
R483	1-216-829-11	METAL CHIP	4.7K	5%	1/10W	R566	1-216-829-11	METAL CHIP	4.7K	5%	1/10W
R484	1-216-809-11	METAL CHIP	100	5%	1/10W	R567	1-218-708-11	METAL CHIP	4.7K	0.50%	1/10W
R489	1-216-829-11	METAL CHIP	4.7K	5%	1/10W	R568	1-216-809-11	METAL CHIP	100	5%	1/10W
R490	1-216-808-11	METAL CHIP	82	5%	1/10W	R569	1-216-809-11	METAL CHIP	100	5%	1/10W
R493	1-216-829-11	METAL CHIP	4.7K	5%	1/10W	R570	1-218-716-11	METAL CHIP	10K	0.50%	1/10W
R495	1-216-829-11	METAL CHIP	4.7K	5%	1/10W	R571	1-216-864-11	SHORT CHIP			
R496	1-216-809-11	METAL CHIP	100	5%	1/10W	R572	1-216-835-11	METAL CHIP	15K	5%	1/10W
R501	1-216-808-11	METAL CHIP	82	5%	1/10W	R574	1-216-833-11	METAL CHIP	10K	5%	1/10W
R502	1-216-825-11	METAL CHIP	2.2K	5%	1/10W	R575	1-216-833-11	METAL CHIP	10K	5%	1/10W
R503	1-216-833-11	METAL CHIP	10K	5%	1/10W	R576	1-216-829-11	METAL CHIP	4.7K	5%	1/10W
R504	1-216-829-11	METAL CHIP	4.7K	5%	1/10W	R577	1-216-829-11	METAL CHIP	4.7K	5%	1/10W
R505	1-216-821-11	METAL CHIP	1K	5%	1/10W	R593	1-216-829-11	METAL CHIP	4.7K	5%	1/10W
R506	1-216-837-11	METAL CHIP	22K	5%	1/10W	R594	1-216-833-11	METAL CHIP	10K	5%	1/10W
R507	1-216-825-11	METAL CHIP	2.2K	5%	1/10W	R596	1-216-841-11	METAL CHIP	47K	5%	1/10W
R508	1-216-825-11	METAL CHIP	2.2K	5%	1/10W	R597	1-216-821-11	METAL CHIP	1K	5%	1/10W
R509	1-216-837-11	METAL CHIP	22K	5%	1/10W	R598	1-216-833-11	METAL CHIP	10K	5%	1/10W
R510	1-216-825-11	METAL CHIP	2.2K	5%	1/10W	R599	1-216-829-11	METAL CHIP	4.7K	5%	1/10W
R512	1-216-864-11	SHORT CHIP				R602	1-216-837-11	METAL CHIP	22K	5%	1/10W
R513	1-216-826-11	METAL CHIP	2.7K	5%	1/10W	R603	1-216-833-11	METAL CHIP	10K	5%	1/10W
R515	1-216-809-11	METAL CHIP	100	5%	1/10W	R604	1-216-833-11	METAL CHIP	10K	5%	1/10W
R516	1-216-809-11	METAL CHIP	100	5%	1/10W	R605	1-216-833-11	METAL CHIP	10K	5%	1/10W
R517	1-216-809-11	METAL CHIP	100	5%	1/10W	R606	1-216-833-11	METAL CHIP	10K	5%	1/10W
R518	1-216-829-11	METAL CHIP	4.7K	5%	1/10W	R607	1-216-833-11	METAL CHIP	10K	5%	1/10W
R519	1-216-821-11	METAL CHIP	1K	5%	1/10W	R608	1-216-833-11	METAL CHIP	10K	5%	1/10W
R521	1-216-833-11	METAL CHIP	10K	5%	1/10W	R609	1-216-809-11	METAL CHIP	100	5%	1/10W
R527	1-216-864-11	SHORT CHIP				R613	1-216-833-11	METAL CHIP	10K	5%	1/10W
R538	1-216-809-11	METAL CHIP	100	5%	1/10W	R616	1-216-833-11	METAL CHIP	10K	5%	1/10W



REF.NO.	PART NO.	DESCRIPTION	VALUES			REF.NO.	PART NO.	DESCRIPTION	VALUES		
R617	1-216-809-11	METAL CHIP	100	5%	1/10W	R744	1-216-821-11	METAL CHIP	1K	5%	1/10W
R618	1-216-809-11	METAL CHIP	100	5%	1/10W	R745	1-216-841-11	METAL CHIP	47K	5%	1/10W
R619	1-216-821-11	METAL CHIP	1K	5%	1/10W	R747	1-216-809-11	METAL CHIP	100	5%	1/10W
R620	1-216-801-11	METAL CHIP	22	5%	1/10W	R748	1-216-833-11	METAL CHIP	10K	5%	1/10W
R621	1-216-801-11	METAL CHIP	22	5%	1/10W	R749	1-216-849-11	METAL CHIP	220K	5%	1/10W
R622	1-216-801-11	METAL CHIP	22	5%	1/10W	R750	1-216-825-11	METAL CHIP	2.2K	5%	1/10W
R624	1-216-809-11	METAL CHIP	100	5%	1/10W	R751	1-216-821-11	METAL CHIP	1K	5%	1/10W
R628	1-249-377-11	CARBON	0.47	5%	1/4W	R752	1-216-821-11	METAL CHIP	1K	5%	1/10W
R701	1-216-817-11	METAL CHIP	470	5%	1/10W	R753	1-216-809-11	METAL CHIP	100	5%	1/10W
R702	1-216-841-11	METAL CHIP	47K	5%	1/10W	R754	1-216-809-11	METAL CHIP	100	5%	1/10W
R703	1-216-821-11	METAL CHIP	1K	5%	1/10W	R755	1-216-809-11	METAL CHIP	100	5%	1/10W
R705	1-216-809-11	METAL CHIP	100	5%	1/10W	R756	1-216-809-11	METAL CHIP	100	5%	1/10W
R706	1-216-809-11	METAL CHIP	100	5%	1/10W	R758	1-216-809-11	METAL CHIP	100	5%	1/10W
R707	1-216-809-11	METAL CHIP	100	5%	1/10W	R759	1-216-821-11	METAL CHIP	1K	5%	1/10W
R708	1-216-809-11	METAL CHIP	100	5%	1/10W	R760	1-216-849-11	METAL CHIP	220K	5%	1/10W
R709	1-216-817-11	METAL CHIP	470	5%	1/10W	R761	1-216-849-11	METAL CHIP	220K	5%	1/10W
R710	1-216-813-11	METAL CHIP	220	5%	1/10W	R762	1-216-845-11	METAL CHIP	100K	5%	1/10W
R711	1-216-833-11	METAL CHIP	10K	5%	1/10W	R763	1-216-815-11	METAL CHIP	330	5%	1/10W
R712	1-216-813-11	METAL CHIP	220	5%	1/10W	R764	1-216-821-11	METAL CHIP	1K	5%	1/10W
R713	1-216-825-11	METAL CHIP	2.2K	5%	1/10W	R765	1-216-815-11	METAL CHIP	330	5%	1/10W
R714	1-216-809-11	METAL CHIP	100	5%	1/10W	R766	1-216-821-11	METAL CHIP	1K	5%	1/10W
R715	1-216-809-11	METAL CHIP	100	5%	1/10W	R767	1-216-833-11	METAL CHIP	10K	5%	1/10W
R716	1-216-821-11	METAL CHIP	1K	5%	1/10W	R768	1-216-809-11	METAL CHIP	100	5%	1/10W
R717	1-216-827-11	METAL CHIP	3.3K	5%	1/10W	R769	1-216-809-11	METAL CHIP	100	5%	1/10W
R718	1-216-827-11	METAL CHIP	3.3K	5%	1/10W	R770	1-216-845-11	METAL CHIP	100K	5%	1/10W
R719	1-216-813-11	METAL CHIP	220	5%	1/10W	R771	1-216-809-11	METAL CHIP	100	5%	1/10W
R720	1-216-809-11	METAL CHIP	100	5%	1/10W	R772	1-216-821-11	METAL CHIP	1K	5%	1/10W
R721	1-216-823-11	METAL CHIP	1.5K	5%	1/10W	R773	1-216-809-11	METAL CHIP	100	5%	1/10W
R722	1-216-825-11	METAL CHIP	2.2K	5%	1/10W	R774	1-216-809-11	METAL CHIP	100	5%	1/10W
R723	1-216-825-11	METAL CHIP	2.2K	5%	1/10W	R775	1-216-821-11	METAL CHIP	1K	5%	1/10W
R724	1-216-825-11	METAL CHIP	2.2K	5%	1/10W	R777	1-216-821-11	METAL CHIP	1K	5%	1/10W
R725	1-216-809-11	METAL CHIP	100	5%	1/10W	R778	1-216-809-11	METAL CHIP	100	5%	1/10W
R727	1-216-825-11	METAL CHIP	2.2K	5%	1/10W	R779	1-216-809-11	METAL CHIP	100	5%	1/10W
R728	1-216-864-11	SHORT CHIP				R781	1-216-823-11	METAL CHIP	1.5K	5%	1/10W
R730	1-216-809-11	METAL CHIP	100	5%	1/10W	R782	1-216-809-11	METAL CHIP	100	5%	1/10W
R732	1-216-809-11	METAL CHIP	100	5%	1/10W	R783	1-216-809-11	METAL CHIP	100	5%	1/10W
R733	1-216-821-11	METAL CHIP	1K	5%	1/10W	R784	1-216-809-11	METAL CHIP	100	5%	1/10W
R735	1-216-833-11	METAL CHIP	10K	5%	1/10W	R785	1-216-821-11	METAL CHIP	1K	5%	1/10W
R736	1-216-813-11	METAL CHIP	220	5%	1/10W	R786	1-216-821-11	METAL CHIP	1K	5%	1/10W
R737	1-216-833-11	METAL CHIP	10K	5%	1/10W	R787	1-216-833-11	METAL CHIP	10K	5%	1/10W
R738	1-218-708-11	METAL CHIP	4.7K	0.50%	1/10W	R788	1-216-845-11	METAL CHIP	100K	5%	1/10W
R740	1-216-809-11	METAL CHIP	100	5%	1/10W	R790	1-216-837-11	METAL CHIP	22K	5%	1/10W
R742	1-216-821-11	METAL CHIP	1K	5%	1/10W	R796	1-216-821-11	METAL CHIP	1K	5%	1/10W
R743	1-216-809-11	METAL CHIP	100	5%	1/10W	R797	1-216-829-11	METAL CHIP	4.7K	5%	1/10W



REF.NO.	PART NO.	DESCRIPTION	VALUES			REF.NO.	PART NO.	DESCRIPTION	VALUES																																
R803	1-216-833-11	METAL CHIP	10K	5%	1/10W	R878	1-216-821-11	METAL CHIP	1K	5%	1/10W																														
R804	1-216-837-11	METAL CHIP	22K	5%	1/10W	R879	1-216-821-11	METAL CHIP	1K	5%	1/10W																														
R806	1-216-829-11	METAL CHIP	4.7K	5%	1/10W	R885	1-216-833-11	METAL CHIP	10K	5%	1/10W																														
R807	1-216-829-11	METAL CHIP	4.7K	5%	1/10W	R886	1-216-833-11	METAL CHIP	10K	5%	1/10W																														
R810	1-216-833-11	METAL CHIP	10K	5%	1/10W	R887	1-216-821-11	METAL CHIP	1K	5%	1/10W																														
R813	1-216-845-11	METAL CHIP	100K	5%	1/10W	R889	1-216-807-11	METAL CHIP	68	5%	1/10W																														
R817	1-216-845-11	METAL CHIP	100K	5%	1/10W	R890	1-216-807-11	METAL CHIP	68	5%	1/10W																														
R818	1-216-833-11	METAL CHIP	10K	5%	1/10W	R891	1-216-807-11	METAL CHIP	68	5%	1/10W																														
R823	1-216-835-11	METAL CHIP	15K	5%	1/10W	R897	1-216-821-11	METAL CHIP	1K	5%	1/10W																														
R828	1-216-817-11	METAL CHIP	470	5%	1/10W	R899	1-216-821-11	METAL CHIP	1K	5%	1/10W																														
R829	1-216-864-11	SHORT CHIP				TUNER																																			
R830	1-216-809-11	METAL CHIP	100	5%	1/10W	TU1	8-598-594-10	TUNER, FSS BTF-FA421																																	
R831	1-216-839-11	METAL CHIP	33K	5%	1/10W	TU2	8-598-593-20	TUNER, FSS BTF-WA421																																	
R832	1-216-817-11	METAL CHIP	470	5%	1/10W	VARISTOR																																			
R833	1-216-839-11	METAL CHIP	33K	5%	1/10W	VD1	1-804-499-21	VARISTOR, CHIP	(1608)																																
R834	1-216-805-11	METAL CHIP	47	5%	1/10W	VD2	1-804-499-21	VARISTOR, CHIP	(1608)																																
R835	1-216-837-11	METAL CHIP	22K	5%	1/10W	VD3	1-804-499-21	VARISTOR, CHIP	(1608)																																
R836	1-216-864-11	SHORT CHIP				VD4	1-804-499-21	VARISTOR, CHIP	(1608)																																
R837	1-216-829-11	METAL CHIP	4.7K	5%	1/10W	CRYSTAL																																			
R838	1-216-809-11	METAL CHIP	100	5%	1/10W	X1	1-767-882-21	VIBRATOR, CRYSTAL																																	
R839	1-216-864-11	SHORT CHIP				X301	1-567-505-11	OSCILLATOR, CRYSTAL																																	
R840	1-216-841-11	METAL CHIP	47K	5%	1/10W	X302	1-767-179-31	VIBRATOR, CERAMIC																																	
R841	1-216-839-11	METAL CHIP	33K	5%	1/10W	X303	1-567-505-11	OSCILLATOR, CRYSTAL																																	
R842	1-216-818-11	METAL CHIP	560	5%	1/10W	X304	1-767-179-31	VIBRATOR, CERAMIC																																	
R844	1-216-864-11	SHORT CHIP				X305	1-781-282-11	VIBRATOR, CERAMIC																																	
R845	1-216-818-11	METAL CHIP	560	5%	1/10W	X307	1-760-895-21	VIBRATOR, CERAMIC																																	
R846	1-218-871-11	METAL CHIP	10K	0.50%	1/10W	X701	1-795-572-11	VIBRATOR, CRYSTAL																																	
R847	1-218-870-11	METAL CHIP	9.1K	0.50%	1/10W	<div style="border: 1px solid black; padding: 5px; display: inline-block;"> AD </div> <p>Due to the complexity of this board, performing component level field repairs is not recommended. If service is required, complete board replacement is the preferred repair method. Data is provided for reference only.</p> <p>* A-1302-179-A AD BOARD, COMPLETE</p> <p>CAPACITOR</p> <table border="0"> <tr> <td>C1601</td> <td>1-126-933-11</td> <td>ELECT</td> <td>100µF</td> <td>20%</td> <td>16V</td> </tr> <tr> <td>C1602</td> <td>1-126-933-11</td> <td>ELECT</td> <td>100µF</td> <td>20%</td> <td>16V</td> </tr> <tr> <td>C1603</td> <td>1-164-156-11</td> <td>CERAMIC CHIP</td> <td>0.1µF</td> <td></td> <td>25V</td> </tr> <tr> <td>C1604</td> <td>1-164-156-11</td> <td>CERAMIC CHIP</td> <td>0.1µF</td> <td></td> <td>25V</td> </tr> <tr> <td>C1605</td> <td>1-164-156-11</td> <td>CERAMIC CHIP</td> <td>0.1µF</td> <td></td> <td>25V</td> </tr> </table>						C1601	1-126-933-11	ELECT	100µF	20%	16V	C1602	1-126-933-11	ELECT	100µF	20%	16V	C1603	1-164-156-11	CERAMIC CHIP	0.1µF		25V	C1604	1-164-156-11	CERAMIC CHIP	0.1µF		25V	C1605	1-164-156-11	CERAMIC CHIP	0.1µF		25V
C1601	1-126-933-11	ELECT	100µF	20%	16V																																				
C1602	1-126-933-11	ELECT	100µF	20%	16V																																				
C1603	1-164-156-11	CERAMIC CHIP	0.1µF		25V																																				
C1604	1-164-156-11	CERAMIC CHIP	0.1µF		25V																																				
C1605	1-164-156-11	CERAMIC CHIP	0.1µF		25V																																				
R848	1-216-836-11	METAL CHIP	18K	5%	1/10W																																				
R849	1-216-836-11	METAL CHIP	18K	5%	1/10W																																				
R851	1-216-833-11	METAL CHIP	10K	5%	1/10W																																				
R853	1-218-871-11	METAL CHIP	10K	0.50%	1/10W																																				
R854	1-216-838-11	METAL CHIP	27K	5%	1/10W																																				
R855	1-216-864-11	SHORT CHIP																																							
R857	1-216-838-11	METAL CHIP	27K	5%	1/10W																																				
R860	1-249-389-11	CARBON	4.7	5%	1/4W																																				
R861	1-249-389-11	CARBON	4.7	5%	1/4W																																				
R862	1-216-839-11	METAL CHIP	33K	5%	1/10W																																				
R863	1-216-841-11	METAL CHIP	47K	5%	1/10W																																				
R864	1-216-829-11	METAL CHIP	4.7K	5%	1/10W																																				
R867	1-216-829-11	METAL CHIP	4.7K	5%	1/10W																																				
R869	1-216-834-11	METAL CHIP	12K	5%	1/10W																																				
R870	1-216-841-11	METAL CHIP	47K	5%	1/10W																																				
R871	1-216-809-11	METAL CHIP	100	5%	1/10W																																				



REF.NO.	PART NO.	DESCRIPTION	VALUES			REF.NO.	PART NO.	DESCRIPTION	VALUES		
C1606	1-164-156-11	CERAMIC CHIP	0.1μF		25V	C1661	1-164-156-11	CERAMIC CHIP	0.1μF		25V
C1607	1-126-933-11	ELECT	100μF	20%	16V	C1663	1-126-933-11	ELECT	100μF	20%	16V
C1608	1-164-156-11	CERAMIC CHIP	0.1μF		25V	C1664	1-126-933-11	ELECT	100μF	20%	16V
C1609	1-162-966-11	CERAMIC CHIP	0.0022μF	10%	50V	C1665	1-126-933-11	ELECT	100μF	20%	16V
C1610	1-162-962-11	CERAMIC CHIP	470pF	10%	50V	C1666	1-162-927-11	CERAMIC CHIP	100pF	5%	50V
C1611	1-164-156-11	CERAMIC CHIP	0.1μF		25V	C1668	1-162-927-11	CERAMIC CHIP	100pF	5%	50V
C1612	1-164-156-11	CERAMIC CHIP	0.1μF		25V	C1669	1-162-910-11	CERAMIC CHIP	5pF	0.25pF	50V
C1613	1-164-156-11	CERAMIC CHIP	0.1μF		25V	C1670	1-164-156-11	CERAMIC CHIP	0.1μF		25V
C1614	1-164-156-11	CERAMIC CHIP	0.1μF		25V	C1671	1-164-156-11	CERAMIC CHIP	0.1μF		25V
C1615	1-164-156-11	CERAMIC CHIP	0.1μF		25V	C1672	1-164-156-11	CERAMIC CHIP	0.1μF		25V
C1616	1-164-156-11	CERAMIC CHIP	0.1μF		25V	C1673	1-162-910-11	CERAMIC CHIP	5pF	0.25pF	50V
C1617	1-164-156-11	CERAMIC CHIP	0.1μF		25V	C1674	1-164-315-11	CERAMIC CHIP	470pF	5%	50V
C1618	1-126-933-11	ELECT	100μF	20%	16V	C1675	1-164-315-11	CERAMIC CHIP	470pF	5%	50V
C1619	1-164-156-11	CERAMIC CHIP	0.1μF		25V	C1676	1-163-137-00	CERAMIC CHIP	680pF	5%	50V
C1621	1-164-156-11	CERAMIC CHIP	0.1μF		25V	C1677	1-126-933-11	ELECT	100μF	20%	16V
C1625	1-164-156-11	CERAMIC CHIP	0.1μF		25V	C1678	1-163-137-00	CERAMIC CHIP	680pF	5%	50V
C1626	1-164-156-11	CERAMIC CHIP	0.1μF		25V	C1680	1-164-156-11	CERAMIC CHIP	0.1μF		25V
C1627	1-164-156-11	CERAMIC CHIP	0.1μF		25V	C1681	1-164-156-11	CERAMIC CHIP	0.1μF		25V
C1628	1-164-156-11	CERAMIC CHIP	0.1μF		25V	C1682	1-164-156-11	CERAMIC CHIP	0.1μF		25V
C1629	1-164-156-11	CERAMIC CHIP	0.1μF		25V	C1683	1-164-156-11	CERAMIC CHIP	0.1μF		25V
C1630	1-164-156-11	CERAMIC CHIP	0.1μF		25V	C1684	1-164-156-11	CERAMIC CHIP	0.1μF		25V
C1631	1-126-933-11	ELECT	100μF	20%	16V	C1685	1-164-156-11	CERAMIC CHIP	0.1μF		25V
C1632	1-164-156-11	CERAMIC CHIP	0.1μF		25V	C1688	1-164-156-11	CERAMIC CHIP	0.1μF		25V
C1633	1-164-156-11	CERAMIC CHIP	0.1μF		25V	C1690	1-162-927-11	CERAMIC CHIP	100pF	5%	50V
C1634	1-126-963-11	ELECT	4.7μF	20%	50V	C1691	1-126-933-11	ELECT	100μF	20%	16V
C1635	1-162-923-11	CERAMIC CHIP	47pF	5%	50V	C1692	1-126-933-11	ELECT	100μF	20%	16V
C1636	1-107-826-11	CERAMIC CHIP	0.1μF	10%	16V	C1693	1-126-933-11	ELECT	100μF	20%	16V
C1637	1-162-919-11	CERAMIC CHIP	22pF	5%	50V	C1694	1-162-927-11	CERAMIC CHIP	100pF	5%	50V
C1638	1-162-919-11	CERAMIC CHIP	22pF	5%	50V	C1695	1-162-910-11	CERAMIC CHIP	5pF	0.25pF	50V
C1639	1-126-933-11	ELECT	100μF	20%	16V	C1696	1-162-910-11	CERAMIC CHIP	5pF	0.25pF	50V
C1640	1-126-933-11	ELECT	100μF	20%	16V	C1697	1-164-156-11	CERAMIC CHIP	0.1μF		25V
C1641	1-164-156-11	CERAMIC CHIP	0.1μF		25V	C1698	1-164-156-11	CERAMIC CHIP	0.1μF		25V
C1643	1-164-156-11	CERAMIC CHIP	0.1μF		25V	C1699	1-164-156-11	CERAMIC CHIP	0.1μF		25V
C1644	1-164-156-11	CERAMIC CHIP	0.1μF		25V	C1700	1-164-156-11	CERAMIC CHIP	0.1μF		25V
C1645	1-164-315-11	CERAMIC CHIP	470pF	5%	50V	C1701	1-162-968-11	CERAMIC CHIP	0.0047μF	10%	50V
C1646	1-164-315-11	CERAMIC CHIP	470pF	5%	50V	C1704	1-126-933-11	ELECT	100μF	20%	16V
C1647	1-163-137-00	CERAMIC CHIP	680pF	5%	50V	C1707	1-164-315-11	CERAMIC CHIP	470pF	5%	50V
C1649	1-163-137-00	CERAMIC CHIP	680pF	5%	50V	C1708	1-163-137-00	CERAMIC CHIP	680pF	5%	50V
C1651	1-164-156-11	CERAMIC CHIP	0.1μF		25V	C1709	1-164-315-11	CERAMIC CHIP	470pF	5%	50V
C1652	1-164-156-11	CERAMIC CHIP	0.1μF		25V	C1711	1-163-137-00	CERAMIC CHIP	680pF	5%	50V
C1656	1-164-156-11	CERAMIC CHIP	0.1μF		25V	C1712	1-164-156-11	CERAMIC CHIP	0.1μF		25V
C1657	1-164-156-11	CERAMIC CHIP	0.1μF		25V	C1714	1-164-156-11	CERAMIC CHIP	0.1μF		25V
C1658	1-164-156-11	CERAMIC CHIP	0.1μF		25V	C1715	1-164-156-11	CERAMIC CHIP	0.1μF		25V
C1659	1-164-156-11	CERAMIC CHIP	0.1μF		25V	C1717	1-162-927-11	CERAMIC CHIP	100pF	5%	50V



REF.NO.	PART NO.	DESCRIPTION	VALUES	REF.NO.	PART NO.	DESCRIPTION	VALUES
C1718	1-164-156-11	CERAMIC CHIP	0.1µF 25V	IC			
C1720	1-162-910-11	CERAMIC CHIP	5pF 0.25pF 50V	IC1601	8-759-683-55	IC	CM0017AF
C1721	1-162-927-11	CERAMIC CHIP	100pF 5% 50V	IC1602	8-759-830-08	IC	NJM2068V-TE2
C1722	1-162-910-11	CERAMIC CHIP	5pF 0.25pF 50V	IC1603	8-759-830-08	IC	NJM2068V-TE2
C1730	1-126-916-11	ELECT	1000µF 20% 6.3V	IC1605	8-759-352-91	IC	PST9143NL
C1731	1-162-970-11	CERAMIC CHIP	0.01µF 10% 25V	IC1606	8-752-933-62	IC	CXP86460-647Q
C1732	1-162-970-11	CERAMIC CHIP	0.01µF 10% 25V	IC1607	6-700-319-01	IC	M24128-BWMN6T
C1733	1-162-970-11	CERAMIC CHIP	0.01µF 10% 25V	IC1608	8-759-829-87	IC	CD0031AM
C1734	1-162-970-11	CERAMIC CHIP	0.01µF 10% 25V	IC1609	8-759-830-08	IC	NJM2068V-TE2
CONNECTOR				IC1610	8-759-830-08	IC	NJM2068V-TE2
CN1601	1-573-301-22	CONNECTOR, BOARD TO BOARD 20P		IC1611	8-759-830-08	IC	NJM2068V-TE2
CN1602	1-573-301-22	CONNECTOR, BOARD TO BOARD 20P		IC1612	8-759-830-08	IC	NJM2068V-TE2
DIODE				COIL			
D1601	8-719-988-61	DIODE	1SS355TE-17	L1602	1-469-555-21	INDUCTOR	10µH
D1603	8-719-988-61	DIODE	1SS355TE-17	TRANSISTOR			
D1604	8-719-069-54	DIODE	UDZSTE-175.1B	Q1603	8-729-120-28	TRANSISTOR	2SC1623-L5L6
D1605	8-719-069-54	DIODE	UDZSTE-175.1B	Q1604	8-729-120-28	TRANSISTOR	2SC1623-L5L6
D1606	8-719-069-54	DIODE	UDZSTE-175.1B	Q1606	8-729-120-28	TRANSISTOR	2SC1623-L5L6
D1607	8-719-069-54	DIODE	UDZSTE-175.1B	Q1607	8-729-120-28	TRANSISTOR	2SC1623-L5L6
D1691	8-719-988-61	DIODE	1SS355TE-17	RESISTOR			
D1692	8-719-988-61	DIODE	1SS355TE-17	R1600	1-216-833-11	METAL CHIP	10K 5% 1/10W
D1693	8-719-988-61	DIODE	1SS355TE-17	R1601	1-216-841-11	METAL CHIP	47K 5% 1/10W
FERRITE BEAD				R1602	1-216-833-11	METAL CHIP	10K 5% 1/10W
FB1601	1-414-445-11	FERRITE	0µH	R1603	1-216-821-11	METAL CHIP	1K 5% 1/10W
FB1602	1-414-445-11	FERRITE	0µH	R1604	1-216-833-11	METAL CHIP	10K 5% 1/10W
FB1603	1-414-445-11	FERRITE	0µH	R1605	1-216-821-11	METAL CHIP	1K 5% 1/10W
FB1604	1-414-445-11	FERRITE	0µH	R1606	1-216-821-11	METAL CHIP	1K 5% 1/10W
FB1605	1-414-445-11	FERRITE	0µH	R1607	1-216-821-11	METAL CHIP	1K 5% 1/10W
FB1606	1-414-445-11	FERRITE	0µH	R1608	1-216-809-11	METAL CHIP	100 5% 1/10W
FB1607	1-414-445-11	FERRITE	0µH	R1609	1-216-809-11	METAL CHIP	100 5% 1/10W
FB1608	1-414-445-11	FERRITE	0µH	R1611	1-216-825-11	METAL CHIP	2.2K 5% 1/10W
FB1609	1-414-445-11	FERRITE	0µH	R1614	1-216-825-11	METAL CHIP	2.2K 5% 1/10W
FB1610	1-414-445-11	FERRITE	0µH	R1615	1-216-821-11	METAL CHIP	1K 5% 1/10W
FB1611	1-414-445-11	FERRITE	0µH	R1618	1-216-809-11	METAL CHIP	100 5% 1/10W
FB1612	1-414-445-11	FERRITE	0µH	R1619	1-216-864-11	SHORT CHIP	
FB1613	1-414-445-11	FERRITE	0µH	R1620	1-216-809-11	METAL CHIP	100 5% 1/10W
FB1614	1-414-445-11	FERRITE	0µH	R1621	1-216-821-11	METAL CHIP	1K 5% 1/10W
FB1615	1-414-445-11	FERRITE	0µH	R1622	1-216-839-11	METAL CHIP	33K 5% 1/10W
FB1616	1-414-445-11	FERRITE	0µH	R1623	1-216-821-11	METAL CHIP	1K 5% 1/10W
FB1617	1-414-445-11	FERRITE	0µH	R1625	1-216-821-11	METAL CHIP	1K 5% 1/10W
				R1627	1-216-821-11	METAL CHIP	1K 5% 1/10W
				R1634	1-216-809-11	METAL CHIP	100 5% 1/10W



REF.NO.	PART NO.	DESCRIPTION	VALUES			REF.NO.	PART NO.	DESCRIPTION	VALUES		
R1635	1-216-809-11	METAL CHIP	100	5%	1/10W	R1686	1-216-809-11	METAL CHIP	100	5%	1/10W
R1636	1-216-833-11	METAL CHIP	10K	5%	1/10W	R1687	1-216-817-11	METAL CHIP	470	5%	1/10W
R1637	1-216-821-11	METAL CHIP	1K	5%	1/10W	R1690	1-218-724-11	METAL CHIP	22K	0.50%	1/10W
R1638	1-216-813-11	METAL CHIP	220	5%	1/10W	R1691	1-218-724-11	METAL CHIP	22K	0.50%	1/10W
R1639	1-216-809-11	METAL CHIP	100	5%	1/10W	R1692	1-218-724-11	METAL CHIP	22K	0.50%	1/10W
R1641	1-216-825-11	METAL CHIP	2.2K	5%	1/10W	R1693	1-218-724-11	METAL CHIP	22K	0.50%	1/10W
R1642	1-216-821-11	METAL CHIP	1K	5%	1/10W	R1694	1-218-716-11	METAL CHIP	10K	0.50%	1/10W
R1643	1-216-821-11	METAL CHIP	1K	5%	1/10W	R1695	1-218-716-11	METAL CHIP	10K	0.50%	1/10W
R1644	1-216-825-11	METAL CHIP	2.2K	5%	1/10W	R1696	1-218-716-11	METAL CHIP	10K	0.50%	1/10W
R1645	1-216-815-11	METAL CHIP	330	5%	1/10W	R1697	1-218-716-11	METAL CHIP	10K	0.50%	1/10W
R1646	1-216-825-11	METAL CHIP	2.2K	5%	1/10W	R1698	1-218-700-11	METAL CHIP	2.2K	0.50%	1/10W
R1647	1-216-833-11	METAL CHIP	10K	5%	1/10W	R1699	1-218-700-11	METAL CHIP	2.2K	0.50%	1/10W
R1648	1-216-809-11	METAL CHIP	100	5%	1/10W	R1700	1-218-700-11	METAL CHIP	2.2K	0.50%	1/10W
R1649	1-216-809-11	METAL CHIP	100	5%	1/10W	R1701	1-218-700-11	METAL CHIP	2.2K	0.50%	1/10W
R1650	1-216-815-11	METAL CHIP	330	5%	1/10W	R1702	1-218-724-11	METAL CHIP	22K	0.50%	1/10W
R1651	1-216-815-11	METAL CHIP	330	5%	1/10W	R1703	1-218-724-11	METAL CHIP	22K	0.50%	1/10W
R1652	1-216-821-11	METAL CHIP	1K	5%	1/10W	R1704	1-218-724-11	METAL CHIP	22K	0.50%	1/10W
R1653	1-216-817-11	METAL CHIP	470	5%	1/10W	R1705	1-218-716-11	METAL CHIP	10K	0.50%	1/10W
R1654	1-216-829-11	METAL CHIP	4.7K	5%	1/10W	R1706	1-218-724-11	METAL CHIP	22K	0.50%	1/10W
R1655	1-218-700-11	METAL CHIP	2.2K	0.50%	1/10W	R1707	1-218-716-11	METAL CHIP	10K	0.50%	1/10W
R1656	1-218-692-11	METAL CHIP	1K	0.50%	1/10W	R1708	1-218-716-11	METAL CHIP	10K	0.50%	1/10W
R1657	1-216-821-11	METAL CHIP	1K	5%	1/10W	R1709	1-218-716-11	METAL CHIP	10K	0.50%	1/10W
R1658	1-216-837-11	METAL CHIP	22K	5%	1/10W	R1711	1-216-833-11	METAL CHIP	10K	5%	1/10W
R1659	1-216-837-11	METAL CHIP	22K	5%	1/10W	R1712	1-216-833-11	METAL CHIP	10K	5%	1/10W
R1660	1-216-821-11	METAL CHIP	1K	5%	1/10W	R1713	1-216-833-11	METAL CHIP	10K	5%	1/10W
R1662	1-216-823-11	METAL CHIP	1.5K	5%	1/10W	R1714	1-216-833-11	METAL CHIP	10K	5%	1/10W
R1665	1-218-700-11	METAL CHIP	2.2K	0.50%	1/10W	RESISTOR BRIDGE					
R1666	1-218-700-11	METAL CHIP	2.2K	0.50%	1/10W	RB1603	1-233-576-11	RES, CHIP NETWORK	100		
R1667	1-218-700-11	METAL CHIP	2.2K	0.50%	1/10W	RB1604	1-233-576-11	RES, CHIP NETWORK	100		
R1668	1-218-700-11	METAL CHIP	2.2K	0.50%	1/10W	RB1605	1-233-576-11	RES, CHIP NETWORK	100		
R1669	1-218-724-11	METAL CHIP	22K	0.50%	1/10W	CRYSTAL					
R1670	1-218-724-11	METAL CHIP	22K	0.50%	1/10W	X1601	1-795-789-21	PIEZOELECTRIC OSCILLATOR			
R1671	1-218-724-11	METAL CHIP	22K	0.50%	1/10W	U					
R1672	1-218-724-11	METAL CHIP	22K	0.50%	1/10W	*					
R1673	1-218-716-11	METAL CHIP	10K	0.50%	1/10W	A-1302-178-A U BOARD, COMPLETE					
R1674	1-218-716-11	METAL CHIP	10K	0.50%	1/10W	CAPACITOR					
R1675	1-218-716-11	METAL CHIP	10K	0.50%	1/10W	C2001	1-163-021-91	CERAMIC CHIP	0.01µF	10%	50V
R1676	1-216-821-11	METAL CHIP	1K	5%	1/10W	C2002	1-163-021-91	CERAMIC CHIP	0.01µF	10%	50V
R1680	1-216-864-11	SHORT CHIP				C2003	1-126-941-11	ELECT	470µF	20%	25V
R1681	1-218-716-11	METAL CHIP	10K	0.50%	1/10W	C2004	1-128-551-11	ELECT	22µF	20%	63V
R1682	1-218-700-11	METAL CHIP	2.2K	0.50%	1/10W	C2005	1-107-826-11	CERAMIC CHIP	0.1µF	10%	16V
R1683	1-218-700-11	METAL CHIP	2.2K	0.50%	1/10W						
R1684	1-218-700-11	METAL CHIP	2.2K	0.50%	1/10W						
R1685	1-218-700-11	METAL CHIP	2.2K	0.50%	1/10W						



REF.NO.	PART NO.	DESCRIPTION	VALUES			REF.NO.	PART NO.	DESCRIPTION	VALUES		
RESISTOR						R2044	1-216-853-11	METAL CHIP	470K	5%	1/10W
R2001	1-218-665-11	METAL CHIP	75	0.50%	1/10W	R2045	1-216-853-11	METAL CHIP	470K	5%	1/10W
R2002	1-216-853-11	METAL CHIP	470K	5%	1/10W	R2046	1-216-818-11	METAL CHIP	560	5%	1/10W
R2003	1-218-665-11	METAL CHIP	75	0.50%	1/10W	R2047	1-216-809-11	METAL CHIP	100	5%	1/10W
R2004	1-218-665-11	METAL CHIP	75	0.50%	1/10W	R2048	1-216-829-11	METAL CHIP	4.7K	5%	1/10W
R2005	1-218-665-11	METAL CHIP	75	0.50%	1/10W	R2049	1-216-809-11	METAL CHIP	100	5%	1/10W
R2006	1-216-853-11	METAL CHIP	470K	5%	1/10W	R2050	1-216-829-11	METAL CHIP	4.7K	5%	1/10W
R2007	1-216-853-11	METAL CHIP	470K	5%	1/10W	R2051	1-216-809-11	METAL CHIP	100	5%	1/10W
R2008	1-218-665-11	METAL CHIP	75	0.50%	1/10W	R2052	1-216-817-11	METAL CHIP	470	5%	1/10W
R2009	1-218-665-11	METAL CHIP	75	0.50%	1/10W	R2053	1-216-817-11	METAL CHIP	470	5%	1/10W
R2010	1-218-665-11	METAL CHIP	75	0.50%	1/10W	R2054	1-216-809-11	METAL CHIP	100	5%	1/10W
R2011	1-216-853-11	METAL CHIP	470K	5%	1/10W	R2055	1-216-821-11	METAL CHIP	1K	5%	1/10W
R2012	1-216-853-11	METAL CHIP	470K	5%	1/10W	R2056	1-216-821-11	METAL CHIP	1K	5%	1/10W
R2013	1-216-853-11	METAL CHIP	470K	5%	1/10W	R2057	1-216-809-11	METAL CHIP	100	5%	1/10W
R2014	1-216-853-11	METAL CHIP	470K	5%	1/10W	R2058	1-218-716-11	METAL CHIP	10K	0.50%	1/10W
R2015	1-216-853-11	METAL CHIP	470K	5%	1/10W	R2059	1-216-817-11	METAL CHIP	470	5%	1/10W
R2016	1-216-853-11	METAL CHIP	470K	5%	1/10W	R2060	1-216-817-11	METAL CHIP	470	5%	1/10W
R2017	1-218-665-11	METAL CHIP	75	0.50%	1/10W	R2061	1-216-817-11	METAL CHIP	470	5%	1/10W
R2018	1-216-853-11	METAL CHIP	470K	5%	1/10W	R2062	1-216-817-11	METAL CHIP	470	5%	1/10W
R2019	1-216-853-11	METAL CHIP	470K	5%	1/10W	R2063	1-216-809-11	METAL CHIP	100	5%	1/10W
R2020	1-218-665-11	METAL CHIP	75	0.50%	1/10W	R2064	1-216-809-11	METAL CHIP	100	5%	1/10W
R2021	1-218-665-11	METAL CHIP	75	0.50%	1/10W	R2065	1-216-825-11	METAL CHIP	2.2K	5%	1/10W
R2022	1-218-665-11	METAL CHIP	75	0.50%	1/10W	R2066	1-216-829-11	METAL CHIP	4.7K	5%	1/10W
R2023	1-216-853-11	METAL CHIP	470K	5%	1/10W	R2067	1-216-809-11	METAL CHIP	100	5%	1/10W
R2024	1-216-853-11	METAL CHIP	470K	5%	1/10W	R2068	1-216-825-11	METAL CHIP	2.2K	5%	1/10W
R2025	1-218-665-11	METAL CHIP	75	0.50%	1/10W	R2069	1-216-825-11	METAL CHIP	2.2K	5%	1/10W
R2026	1-218-665-11	METAL CHIP	75	0.50%	1/10W	R2070	1-216-825-11	METAL CHIP	2.2K	5%	1/10W
R2027	1-218-665-11	METAL CHIP	75	0.50%	1/10W	R2071	1-216-809-11	METAL CHIP	100	5%	1/10W
R2028	1-218-716-11	METAL CHIP	10K	0.50%	1/10W	R2072	1-216-829-11	METAL CHIP	4.7K	5%	1/10W
R2029	1-218-716-11	METAL CHIP	10K	0.50%	1/10W	R2073	1-216-809-11	METAL CHIP	100	5%	1/10W
R2030	1-216-809-11	METAL CHIP	100	5%	1/10W	R2074	1-216-809-11	METAL CHIP	100	5%	1/10W
R2031	1-216-841-11	METAL CHIP	47K	5%	1/10W	R2075	1-216-809-11	METAL CHIP	100	5%	1/10W
R2032	1-216-845-11	METAL CHIP	100K	5%	1/10W	R2077	1-216-809-11	METAL CHIP	100	5%	1/10W
R2034	1-216-803-11	METAL CHIP	33	5%	1/10W	R2078	1-216-864-11	SHORT CHIP			
R2035	1-216-809-11	METAL CHIP	100	5%	1/10W	R2080	1-216-809-11	METAL CHIP	100	5%	1/10W
R2036	1-216-809-11	METAL CHIP	100	5%	1/10W	R2081	1-216-809-11	METAL CHIP	100	5%	1/10W
R2037	1-216-809-11	METAL CHIP	100	5%	1/10W	R2082	1-216-829-11	METAL CHIP	4.7K	5%	1/10W
R2038	1-216-809-11	METAL CHIP	100	5%	1/10W	R2083	1-216-864-11	SHORT CHIP			
R2039	1-216-833-11	METAL CHIP	10K	5%	1/10W	R2084	1-216-809-11	METAL CHIP	100	5%	1/10W
R2040	1-216-857-11	METAL CHIP	1M	5%	1/10W	R2085	1-216-821-11	METAL CHIP	1K	5%	1/10W
R2041	1-216-842-11	METAL CHIP	56K	5%	1/10W	R2086	1-216-829-11	METAL CHIP	4.7K	5%	1/10W
R2042	1-216-825-11	METAL CHIP	2.2K	5%	1/10W	R2087	1-216-809-11	METAL CHIP	100	5%	1/10W
R2043	1-216-809-11	METAL CHIP	100	5%	1/10W	R2088	1-216-864-11	SHORT CHIP			
						R2089	1-216-809-11	METAL CHIP	100	5%	1/10W



REF.NO.	PART NO.	DESCRIPTION	VALUES			REF.NO.	PART NO.	DESCRIPTION	VALUES		
R2090	1-216-821-11	METAL CHIP	1K	5%	1/10W	R2159	1-216-832-11	METAL CHIP	8.2K	5%	1/10W
R2092	1-216-829-11	METAL CHIP	4.7K	5%	1/10W	R2164	1-218-710-11	METAL CHIP	5.6K	0.50%	1/10W
R2094	1-216-864-11	SHORT CHIP				R2166	1-216-818-11	METAL CHIP	560	5%	1/10W
R2096	1-216-809-11	METAL CHIP	100	5%	1/10W	R2169	1-216-842-11	METAL CHIP	56K	5%	1/10W
R2097	1-216-809-11	METAL CHIP	100	5%	1/10W	R2173	1-216-818-11	METAL CHIP	560	5%	1/10W
R2098	1-216-825-11	METAL CHIP	2.2K	5%	1/10W	R2174	1-218-686-11	METAL CHIP	560	0.50%	1/10W
R2099	1-216-809-11	METAL CHIP	100	5%	1/10W	R2175	1-216-817-11	METAL CHIP	470	5%	1/10W
R2100	1-216-825-11	METAL CHIP	2.2K	5%	1/10W	R2176	1-216-825-11	METAL CHIP	2.2K	5%	1/10W
R2103	1-216-809-11	METAL CHIP	100	5%	1/10W	R2177	1-216-809-11	METAL CHIP	100	5%	1/10W
R2104	1-216-809-11	METAL CHIP	100	5%	1/10W	R2178	1-218-676-11	METAL CHIP	220	0.50%	1/10W
R2105	1-216-809-11	METAL CHIP	100	5%	1/10W	R2182	1-216-864-11	SHORT CHIP			
R2107	1-216-807-11	METAL CHIP	68	5%	1/10W	R2183	1-216-813-11	METAL CHIP	220	5%	1/10W
R2108	1-216-841-11	METAL CHIP	47K	5%	1/10W	R2184	1-218-704-11	METAL CHIP	3.3K	0.50%	1/10W
R2109	1-216-809-11	METAL CHIP	100	5%	1/10W	R2185	1-218-684-11	METAL CHIP	470	0.50%	1/10W
R2110	1-216-809-11	METAL CHIP	100	5%	1/10W	R2186	1-218-688-11	METAL CHIP	680	0.50%	1/10W
R2111	1-216-825-11	METAL CHIP	2.2K	5%	1/10W	R2187	1-216-864-11	SHORT CHIP			
R2113	1-216-821-11	METAL CHIP	1K	5%	1/10W	R2193	1-216-809-11	METAL CHIP	100	5%	1/10W
R2114	1-216-845-11	METAL CHIP	100K	5%	1/10W	R2194	1-216-817-11	METAL CHIP	470	5%	1/10W
R2115	1-216-845-11	METAL CHIP	100K	5%	1/10W	R2195	1-216-817-11	METAL CHIP	470	5%	1/10W
R2116	1-216-832-11	METAL CHIP	8.2K	5%	1/10W	R2196	1-216-817-11	METAL CHIP	470	5%	1/10W
R2118	1-216-821-11	METAL CHIP	1K	5%	1/10W	R2197	1-216-817-11	METAL CHIP	470	5%	1/10W
R2121	1-216-809-11	METAL CHIP	100	5%	1/10W	R2198	1-216-853-11	METAL CHIP	470K	5%	1/10W
R2122	1-216-821-11	METAL CHIP	1K	5%	1/10W	R2199	1-216-853-11	METAL CHIP	470K	5%	1/10W
R2123	1-218-684-11	METAL CHIP	470	0.50%	1/10W						
R2124	1-216-821-11	METAL CHIP	1K	5%	1/10W						
R2125	1-218-702-11	METAL CHIP	2.7K	0.50%	1/10W						
R2130	1-216-805-11	METAL CHIP	47	5%	1/10W						
R2131	1-216-825-11	METAL CHIP	2.2K	5%	1/10W						
R2132	1-216-833-11	METAL CHIP	10K	5%	1/10W						
R2133	1-218-674-11	METAL CHIP	180	0.50%	1/10W						
R2136	1-216-816-11	METAL CHIP	390	5%	1/10W						
R2137	1-218-700-11	METAL CHIP	2.2K	0.50%	1/10W						
R2138	1-216-809-11	METAL CHIP	100	5%	1/10W						
R2142	1-216-815-11	METAL CHIP	330	5%	1/10W						
R2147	1-216-814-11	METAL CHIP	270	5%	1/10W						
R2148	1-218-710-11	METAL CHIP	5.6K	0.50%	1/10W						
R2149	1-216-817-11	METAL CHIP	470	5%	1/10W						
R2150	1-216-821-11	METAL CHIP	1K	5%	1/10W						
R2151	1-218-698-11	METAL CHIP	1.8K	0.50%	1/10W						
R2152	1-218-694-11	METAL CHIP	1.2K	0.50%	1/10W						
R2153	1-216-821-11	METAL CHIP	1K	5%	1/10W						
R2155	1-216-837-11	METAL CHIP	22K	5%	1/10W						
R2156	1-216-841-11	METAL CHIP	47K	5%	1/10W						
R2157	1-216-825-11	METAL CHIP	2.2K	5%	1/10W						



Due to the complexity of this board, performing component level field repairs is not recommended. If service is required, complete board replacement is the preferred repair method. Data is provided for reference only.

- * **A-1302-209-A B BOARD, COMPLETE**
- 4-382-854-11 SCREW (M3X10), P, SW (+)
- * 7-651-000-50 GREASE, SILICON (G-746) 200G

CAPACITOR

C3001	1-128-453-21	ELECT CHIP	47µF	20%	6.3V
C3002	1-128-453-21	ELECT CHIP	47µF	20%	6.3V
C3003	1-128-453-21	ELECT CHIP	47µF	20%	6.3V
C3035	1-162-970-11	CERAMIC CHIP	0.01µF	10%	25V
C3044	1-164-156-11	CERAMIC CHIP	0.1µF		25V
C3089	1-162-970-11	CERAMIC CHIP	0.01µF	10%	25V
C3090	1-126-204-11	ELECT CHIP	47µF	20%	16V
C3096	1-162-970-11	CERAMIC CHIP	0.01µF	10%	25V
C3101	1-162-925-11	CERAMIC CHIP	68pF	5%	50V
C3102	1-162-925-11	CERAMIC CHIP	68pF	5%	50V



REF.NO.	PART NO.	DESCRIPTION	VALUES			REF.NO.	PART NO.	DESCRIPTION	VALUES		
C3301	1-164-156-11	CERAMIC CHIP	0.1μF	25V		C3347	1-164-156-11	CERAMIC CHIP	0.1μF	25V	
C3302	1-164-156-11	CERAMIC CHIP	0.1μF	25V		C3348	1-164-156-11	CERAMIC CHIP	0.1μF	25V	
C3303	1-126-206-11	ELECT CHIP	100μF	20%	6.3V	C3349	1-164-156-11	CERAMIC CHIP	0.1μF	25V	
C3304	1-164-156-11	CERAMIC CHIP	0.1μF	25V		C3350	1-164-156-11	CERAMIC CHIP	0.1μF	25V	
C3305	1-164-156-11	CERAMIC CHIP	0.1μF	25V		C3351	1-164-156-11	CERAMIC CHIP	0.1μF	25V	
C3306	1-126-204-11	ELECT CHIP	47μF	20%	16V	C3352	1-124-779-00	ELECT CHIP	10μF	20% 16V	
C3307	1-164-156-11	CERAMIC CHIP	0.1μF	25V		C3353	1-126-204-11	ELECT CHIP	47μF	20% 16V	
C3308	1-164-156-11	CERAMIC CHIP	0.1μF	25V		C3354	1-164-156-11	CERAMIC CHIP	0.1μF	25V	
C3309	1-126-206-11	ELECT CHIP	100μF	20%	6.3V	C3355	1-164-156-11	CERAMIC CHIP	0.1μF	25V	
C3310	1-164-156-11	CERAMIC CHIP	0.1μF	25V		C3356	1-126-204-11	ELECT CHIP	47μF	20% 16V	
C3311	1-164-156-11	CERAMIC CHIP	0.1μF	25V		C3357	1-164-156-11	CERAMIC CHIP	0.1μF	25V	
C3312	1-126-206-11	ELECT CHIP	100μF	20%	6.3V	C3358	1-164-156-11	CERAMIC CHIP	0.1μF	25V	
C3313	1-164-156-11	CERAMIC CHIP	0.1μF	25V		C3359	1-126-204-11	ELECT CHIP	47μF	20% 16V	
C3314	1-164-156-11	CERAMIC CHIP	0.1μF	25V		C3360	1-164-156-11	CERAMIC CHIP	0.1μF	25V	
C3315	1-164-156-11	CERAMIC CHIP	0.1μF	25V		C3361	1-162-970-11	CERAMIC CHIP	0.01μF	10% 25V	
C3316	1-164-156-11	CERAMIC CHIP	0.1μF	25V		C3362	1-127-760-11	CERAMIC CHIP	4.7μF	10% 6.3V	
C3317	1-164-156-11	CERAMIC CHIP	0.1μF	25V		C3363	1-126-204-11	ELECT CHIP	47μF	20% 16V	
C3318	1-164-156-11	CERAMIC CHIP	0.1μF	25V		C3364	1-164-156-11	CERAMIC CHIP	0.1μF	25V	
C3319	1-164-156-11	CERAMIC CHIP	0.1μF	25V		C3365	1-164-156-11	CERAMIC CHIP	0.1μF	25V	
C3320	1-164-156-11	CERAMIC CHIP	0.1μF	25V		C3366	1-164-156-11	CERAMIC CHIP	0.1μF	25V	
C3321	1-164-156-11	CERAMIC CHIP	0.1μF	25V		C3367	1-164-156-11	CERAMIC CHIP	0.1μF	25V	
C3322	1-126-204-11	ELECT CHIP	47μF	20%	16V	C3368	1-164-156-11	CERAMIC CHIP	0.1μF	25V	
C3323	1-124-779-00	ELECT CHIP	10μF	20%	16V	C3369	1-164-156-11	CERAMIC CHIP	0.1μF	25V	
C3324	1-164-156-11	CERAMIC CHIP	0.1μF	25V		C3370	1-164-156-11	CERAMIC CHIP	0.1μF	25V	
C3325	1-164-156-11	CERAMIC CHIP	0.1μF	25V		C3371	1-164-156-11	CERAMIC CHIP	0.1μF	25V	
C3326	1-164-156-11	CERAMIC CHIP	0.1μF	25V		C3372	1-164-156-11	CERAMIC CHIP	0.1μF	25V	
C3327	1-164-156-11	CERAMIC CHIP	0.1μF	25V		C3373	1-162-915-11	CERAMIC CHIP	10pF	0.50pF 50V	
C3328	1-124-779-00	ELECT CHIP	10μF	20%	16V	C3374	1-164-156-11	CERAMIC CHIP	0.1μF	25V	
C3329	1-107-826-11	CERAMIC CHIP	0.1μF	10%	16V	C3375	1-127-760-11	CERAMIC CHIP	4.7μF	10% 6.3V	
C3331	1-126-204-11	ELECT CHIP	47μF	20%	16V	C3376	1-164-156-11	CERAMIC CHIP	0.1μF	25V	
C3332	1-124-779-00	ELECT CHIP	10μF	20%	16V	C3377	1-162-970-11	CERAMIC CHIP	0.01μF	10% 25V	
C3333	1-164-156-11	CERAMIC CHIP	0.1μF	25V		C3378	1-126-204-11	ELECT CHIP	47μF	20% 16V	
C3334	1-107-826-11	CERAMIC CHIP	0.1μF	10%	16V	C3379	1-164-156-11	CERAMIC CHIP	0.1μF	25V	
C3335	1-164-156-11	CERAMIC CHIP	0.1μF	25V		C3401	1-164-156-11	CERAMIC CHIP	0.1μF	25V	
C3336	1-124-779-00	ELECT CHIP	10μF	20%	16V	C3402	1-124-779-00	ELECT CHIP	10μF	20% 16V	
C3337	1-107-826-11	CERAMIC CHIP	0.1μF	10%	16V	C3403	1-164-156-11	CERAMIC CHIP	0.1μF	25V	
C3338	1-164-156-11	CERAMIC CHIP	0.1μF	25V		C3404	1-126-206-11	ELECT CHIP	100μF	20% 6.3V	
C3339	1-164-156-11	CERAMIC CHIP	0.1μF	25V		C3405	1-126-206-11	ELECT CHIP	100μF	20% 6.3V	
C3340	1-164-156-11	CERAMIC CHIP	0.1μF	25V		C3406	1-107-826-11	CERAMIC CHIP	0.1μF	10% 16V	
C3341	1-164-156-11	CERAMIC CHIP	0.1μF	25V		C3407	1-107-826-11	CERAMIC CHIP	0.1μF	10% 16V	
C3343	1-164-156-11	CERAMIC CHIP	0.1μF	25V		C3408	1-126-206-11	ELECT CHIP	100μF	20% 6.3V	
C3344	1-164-156-11	CERAMIC CHIP	0.1μF	25V		C3409	1-164-156-11	CERAMIC CHIP	0.1μF	25V	
C3345	1-126-204-11	ELECT CHIP	47μF	20%	16V	C3410	1-164-156-11	CERAMIC CHIP	0.1μF	25V	
C3346	1-164-156-11	CERAMIC CHIP	0.1μF	25V		C3411	1-164-156-11	CERAMIC CHIP	0.1μF	25V	



REF.NO.	PART NO.	DESCRIPTION	VALUES			REF.NO.	PART NO.	DESCRIPTION	VALUES		
C3412	1-164-156-11	CERAMIC CHIP	0.1μF		25V	C3458	1-164-156-11	CERAMIC CHIP	0.1μF		25V
C3413	1-164-156-11	CERAMIC CHIP	0.1μF		25V	C3460	1-162-923-11	CERAMIC CHIP	47pF	5%	50V
C3414	1-164-156-11	CERAMIC CHIP	0.1μF		25V	C3462	1-164-156-11	CERAMIC CHIP	0.1μF		25V
C3415	1-124-779-00	ELECT CHIP	10μF	20%	16V	C3463	1-164-156-11	CERAMIC CHIP	0.1μF		25V
C3416	1-164-156-11	CERAMIC CHIP	0.1μF		25V	C3464	1-164-156-11	CERAMIC CHIP	0.1μF		25V
C3417	1-164-156-11	CERAMIC CHIP	0.1μF		25V	C3465	1-164-156-11	CERAMIC CHIP	0.1μF		25V
C3418	1-107-826-11	CERAMIC CHIP	0.1μF	10%	16V	C3466	1-164-156-11	CERAMIC CHIP	0.1μF		25V
C3419	1-164-156-11	CERAMIC CHIP	0.1μF		25V	C3467	1-164-156-11	CERAMIC CHIP	0.1μF		25V
C3420	1-124-779-00	ELECT CHIP	10μF	20%	16V	C3468	1-126-206-11	ELECT CHIP	100μF	20%	6.3V
C3421	1-164-156-11	CERAMIC CHIP	0.1μF		25V	C3469	1-164-156-11	CERAMIC CHIP	0.1μF		25V
C3422	1-164-156-11	CERAMIC CHIP	0.1μF		25V	C3470	1-126-206-11	ELECT CHIP	100μF	20%	6.3V
C3423	1-162-970-11	CERAMIC CHIP	0.01μF	10%	25V	C3473	1-164-156-11	CERAMIC CHIP	0.1μF		25V
C3424	1-164-156-11	CERAMIC CHIP	0.1μF		25V	C3474	1-124-779-00	ELECT CHIP	10μF	20%	16V
C3425	1-125-891-11	CERAMIC CHIP	0.47μF	10%	10V	C3475	1-164-156-11	CERAMIC CHIP	0.1μF		25V
C3426	1-164-156-11	CERAMIC CHIP	0.1μF		25V	C3476	1-124-779-00	ELECT CHIP	10μF	20%	16V
C3428	1-107-826-11	CERAMIC CHIP	0.1μF	10%	16V	C3477	1-164-156-11	CERAMIC CHIP	0.1μF		25V
C3429	1-124-779-00	ELECT CHIP	10μF	20%	16V	C3478	1-126-204-11	ELECT CHIP	47μF	20%	16V
C3430	1-164-156-11	CERAMIC CHIP	0.1μF		25V	C3479	1-124-779-00	ELECT CHIP	10μF	20%	16V
C3431	1-126-204-11	ELECT CHIP	47μF	20%	16V	C3480	1-164-156-11	CERAMIC CHIP	0.1μF		25V
C3432	1-164-156-11	CERAMIC CHIP	0.1μF		25V	C3481	1-117-681-11	ELECT CHIP	100μF	20%	16V
C3433	1-162-970-11	CERAMIC CHIP	0.01μF	10%	25V	C3482	1-117-681-11	ELECT CHIP	100μF	20%	16V
C3434	1-126-204-11	ELECT CHIP	47μF	20%	16V	C3483	1-117-681-11	ELECT CHIP	100μF	20%	16V
C3435	1-164-156-11	CERAMIC CHIP	0.1μF		25V	C3484	1-125-837-91	CERAMIC CHIP	1μF	10%	6.3V
C3436	1-107-826-11	CERAMIC CHIP	0.1μF	10%	16V	C3485	1-164-156-11	CERAMIC CHIP	0.1μF		25V
C3437	1-126-204-11	ELECT CHIP	47μF	20%	16V	C3486	1-164-156-11	CERAMIC CHIP	0.1μF		25V
C3438	1-164-156-11	CERAMIC CHIP	0.1μF		25V	C3487	1-164-156-11	CERAMIC CHIP	0.1μF		25V
C3439	1-164-156-11	CERAMIC CHIP	0.1μF		25V	C3488	1-124-779-00	ELECT CHIP	10μF	20%	16V
C3440	1-162-916-11	CERAMIC CHIP	12pF	5%	50V	C3489	1-164-156-11	CERAMIC CHIP	0.1μF		25V
C3441	1-162-916-11	CERAMIC CHIP	12pF	5%	50V	C3490	1-124-779-00	ELECT CHIP	10μF	20%	16V
C3442	1-124-779-00	ELECT CHIP	10μF	20%	16V	C3491	1-126-204-11	ELECT CHIP	47μF	20%	16V
C3443	1-162-970-11	CERAMIC CHIP	0.01μF	10%	25V	C3492	1-164-156-11	CERAMIC CHIP	0.1μF		25V
C3444	1-164-156-11	CERAMIC CHIP	0.1μF		25V	C3493	1-126-204-11	ELECT CHIP	47μF	20%	16V
C3445	1-126-204-11	ELECT CHIP	47μF	20%	16V	C3494	1-164-156-11	CERAMIC CHIP	0.1μF		25V
C3446	1-107-826-11	CERAMIC CHIP	0.1μF	10%	16V	C3495	1-124-779-00	ELECT CHIP	10μF	20%	16V
C3447	1-164-156-11	CERAMIC CHIP	0.1μF		25V	C3496	1-164-156-11	CERAMIC CHIP	0.1μF		25V
C3448	1-162-970-11	CERAMIC CHIP	0.01μF	10%	25V	C3499	1-162-970-11	CERAMIC CHIP	0.01μF	10%	25V
C3449	1-164-156-11	CERAMIC CHIP	0.1μF		25V	CONNECTOR					
C3450	1-164-156-11	CERAMIC CHIP	0.1μF		25V	* CN3203	1-793-923-11	CONNECTOR, DIN (PLUG)			64P
C3452	1-164-156-11	CERAMIC CHIP	0.1μF		25V	DIODE					
C3453	1-124-779-00	ELECT CHIP	10μF	20%	16V	D3089	8-719-062-51	DIODE			1PS226-115
C3454	1-164-156-11	CERAMIC CHIP	0.1μF		25V	D3090	8-719-062-51	DIODE			1PS226-115
C3455	1-124-779-00	ELECT CHIP	10μF	20%	16V	D3099	8-719-988-61	DIODE			1SS355TE-17
C3456	1-164-156-11	CERAMIC CHIP	0.1μF		25V	D3301	8-719-083-58	DIODE			UDZSTE-173.9B
C3457	1-124-779-00	ELECT CHIP	10μF	20%	16V						



REF.NO.	PART NO.	DESCRIPTION	VALUES	REF.NO.	PART NO.	DESCRIPTION	VALUES
D3302	8-719-069-60	DIODE	UDZSTE-179.1B	COIL			
D3401	8-719-914-43	DIODE	DAN202K	L3001	1-216-295-91	SHORT CHIP	
D3402	8-719-914-44	DIODE	DAP202K	L3089	1-414-233-22	FERRITE	0μH
D3403	8-719-978-33	DIODE	DTZ-TT11-6.8B	L3102	1-412-946-11	INDUCTOR	3.9μH
FERRITE BEAD				L3301	1-412-058-11	INDUCTOR	10μH
FB3302	1-500-451-11	FERRITE	0μH	L3302	1-469-555-21	INDUCTOR	10μH
FB3303	1-469-110-21	FERRITE	0μH	L3303	1-412-052-21	INDUCTOR	1μH
FB3401	1-414-235-22	FERRITE	0μH	L3304	1-469-555-21	INDUCTOR	10μH
FB3402	1-414-235-22	FERRITE	0μH	L3305	1-469-555-21	INDUCTOR	10μH
FILTER				L3306	1-469-561-21	INDUCTOR	100μH
FL3003	1-781-924-21	FILTER, LOW PASS (SMD)		L3307	1-469-555-21	INDUCTOR	10μH
FL3301	1-234-558-21	FILTER, LOW PASS		L3308	1-469-561-21	INDUCTOR	100μH
FL3302	1-234-557-21	FILTER, LOW PASS		L3309	1-469-561-21	INDUCTOR	100μH
FL3303	1-234-557-21	FILTER, LOW PASS		L3310	1-469-561-21	INDUCTOR	100μH
FL3401	1-781-923-21	FILTER, LOW PASS (SMD)		L3311	1-469-561-21	INDUCTOR	100μH
IC				L3312	1-469-555-21	INDUCTOR	10μH
IC3089	6-700-149-01	IC	M24C04-MN6T(A)	L3401	1-412-058-11	INDUCTOR	10μH
IC3090	6-802-930-01	IC	MB94918RpF-G-161-BND	L3402	1-412-052-21	INDUCTOR	1μH
IC3091	8-759-349-11	IC	PST9145NL	L3403	1-469-561-21	INDUCTOR	100μH
IC3301	8-759-663-74	IC	HY57V161610DTC-7TR	L3404	1-469-561-21	INDUCTOR	100μH
IC3302	8-759-832-05	IC	BA18BC0FP-E2	L3405	1-469-555-21	INDUCTOR	10μH
IC3303	8-752-409-78	IC	CXD2095AQ	L3406	1-469-555-21	INDUCTOR	10μH
IC3304	8-759-447-90	IC	TLC5733AIPM	L3407	1-469-555-21	INDUCTOR	10μH
IC3305	8-759-669-75	IC	TLC2932IPWR	L3409	1-469-555-21	INDUCTOR	10μH
IC3306	8-759-669-78	IC	TLC2933IPWR-12	L3410	1-412-058-11	INDUCTOR	10μH
IC3401	6-700-394-01	IC	BA25BC0FP-E2	L3411	1-412-058-11	INDUCTOR	10μH
IC3402	6-703-430-01	IC	MT48LC2M32B2TG-6-Y94W	L3412	1-469-555-21	INDUCTOR	10μH
IC3403	8-759-460-29	IC	PST9120NL	L3413	1-469-555-21	INDUCTOR	10μH
IC3404	8-759-669-75	IC	TLC2932IPWR	L3414	1-469-555-21	INDUCTOR	10μH
IC3405	8-759-485-79	IC	TC7SET08FU(TE85L)	L3416	1-469-555-21	INDUCTOR	10μH
IC3406	8-759-485-79	IC	TC7SET08FU(TE85L)	TRANSISTOR			
IC3407	8-759-485-79	IC	TC7SET08FU(TE85L)	Q3005	8-729-120-28	TRANSISTOR	2SC1623-L5L6
IC3408	8-759-672-57	IC	CXD9509AQ	Q3006	8-729-120-28	TRANSISTOR	2SC1623-L5L6
IC3409	8-759-833-72	IC	NJM2870F25-TE2	Q3007	8-729-120-28	TRANSISTOR	2SC1623-L5L6
IC3410	8-752-367-59	IC	CXD2309Q	Q3089	8-729-026-49	TRANSISTOR	2SA1037AK-T146-R
IC3411	8-759-082-57	IC	TC7W04FU	Q3090	8-729-026-49	TRANSISTOR	2SA1037AK-T146-R
IC3412	8-759-082-58	IC	TC7W08FU	Q3091	1-801-806-11	TRANSISTOR	DTC144EKA
IC3413	8-759-595-97	IC	SN74LV4053ANSR	Q3301	8-729-120-28	TRANSISTOR	2SC1623-L5L6
IC3414	8-759-548-56	IC	M52055FP	Q3302	8-729-120-28	TRANSISTOR	2SC1623-L5L6
				Q3303	8-729-120-28	TRANSISTOR	2SC1623-L5L6
				Q3304	8-729-120-28	TRANSISTOR	2SC1623-L5L6
				Q3305	8-729-026-49	TRANSISTOR	2SA1037AK-T146-R
				Q3306	8-729-026-49	TRANSISTOR	2SA1037AK-T146-R



REF.NO.	PART NO.	DESCRIPTION	VALUES	REF.NO.	PART NO.	DESCRIPTION	VALUES
Q3307	8-729-120-28	TRANSISTOR	2SC1623-L5L6	R3101	1-216-809-11	METAL CHIP	100 5% 1/10W
Q3308	8-729-026-49	TRANSISTOR	2SA1037AK-T146-R	R3102	1-216-809-11	METAL CHIP	100 5% 1/10W
Q3309	8-729-120-28	TRANSISTOR	2SC1623-L5L6	R3103	1-216-822-11	METAL CHIP	1.2K 5% 1/10W
Q3310	8-729-026-49	TRANSISTOR	2SA1037AK-T146-R	R3104	1-216-809-11	METAL CHIP	100 5% 1/10W
Q3311	8-729-120-28	TRANSISTOR	2SC1623-L5L6	R3105	1-216-809-11	METAL CHIP	100 5% 1/10W
Q3401	8-729-120-28	TRANSISTOR	2SC1623-L5L6	R3106	1-216-818-11	METAL CHIP	560 5% 1/10W
Q3402	8-729-028-28	TRANSISTOR	2SK2036(TE85L)	R3107	1-216-864-11	SHORT CHIP	
Q3403	8-729-120-28	TRANSISTOR	2SC1623-L5L6	R3108	1-216-817-11	METAL CHIP	470 5% 1/10W
Q3404	8-729-028-28	TRANSISTOR	2SK2036(TE85L)	R3109	1-216-823-11	METAL CHIP	1.5K 5% 1/10W
Q3405	8-729-026-49	TRANSISTOR	2SA1037AK-T146-R	R3110	1-216-809-11	METAL CHIP	100 5% 1/10W
Q3406	8-729-026-49	TRANSISTOR	2SA1037AK-T146-R	R3111	1-216-809-11	METAL CHIP	100 5% 1/10W
Q3407	8-729-120-28	TRANSISTOR	2SC1623-L5L6	R3301	1-216-809-11	METAL CHIP	100 5% 1/10W
Q3408	8-729-026-49	TRANSISTOR	2SA1037AK-T146-R	R3302	1-216-817-11	METAL CHIP	470 5% 1/10W
Q3409	8-729-120-28	TRANSISTOR	2SC1623-L5L6	R3303	1-218-710-11	METAL CHIP	5.6K 0.50% 1/10W
Q3410	8-729-026-49	TRANSISTOR	2SA1037AK-T146-R	R3304	1-216-809-11	METAL CHIP	100 5% 1/10W
Q3411	8-729-026-49	TRANSISTOR	2SA1037AK-T146-R	R3305	1-216-809-11	METAL CHIP	100 5% 1/10W
Q3412	8-729-026-49	TRANSISTOR	2SA1037AK-T146-R	R3306	1-216-809-11	METAL CHIP	100 5% 1/10W
Q3413	8-729-026-49	TRANSISTOR	2SA1037AK-T146-R	R3307	1-216-864-11	SHORT CHIP	
Q3414	8-729-026-49	TRANSISTOR	2SA1037AK-T146-R	R3308	1-216-864-11	SHORT CHIP	
Q3415	8-729-026-49	TRANSISTOR	2SA1037AK-T146-R	R3309	1-218-662-11	METAL CHIP	56 0.50% 1/10W
RESISTOR				R3310	1-218-662-11	METAL CHIP	56 0.50% 1/10W
R3001	1-216-833-11	METAL CHIP	10K 5% 1/10W	R3311	1-218-662-11	METAL CHIP	56 0.50% 1/10W
R3002	1-216-864-11	SHORT CHIP		R3312	1-218-662-11	METAL CHIP	56 0.50% 1/10W
R3021	1-216-809-11	METAL CHIP	100 5% 1/10W	R3313	1-216-835-11	METAL CHIP	15K 5% 1/10W
R3022	1-216-809-11	METAL CHIP	100 5% 1/10W	R3314	1-218-665-11	METAL CHIP	75 0.50% 1/10W
R3023	1-216-833-11	METAL CHIP	10K 5% 1/10W	R3315	1-216-835-11	METAL CHIP	15K 5% 1/10W
R3035	1-216-809-11	METAL CHIP	100 5% 1/10W	R3316	1-218-664-11	METAL CHIP	68 0.50% 1/10W
R3036	1-216-809-11	METAL CHIP	100 5% 1/10W	R3317	1-218-664-11	METAL CHIP	68 0.50% 1/10W
R3037	1-216-809-11	METAL CHIP	100 5% 1/10W	R3318	1-218-665-11	METAL CHIP	75 0.50% 1/10W
R3038	1-218-686-11	METAL CHIP	560 0.50% 1/10W	R3319	1-218-662-11	METAL CHIP	56 0.50% 1/10W
R3039	1-218-686-11	METAL CHIP	560 0.50% 1/10W	R3320	1-218-662-11	METAL CHIP	56 0.50% 1/10W
R3040	1-218-686-11	METAL CHIP	560 0.50% 1/10W	R3321	1-218-662-11	METAL CHIP	56 0.50% 1/10W
R3050	1-216-809-11	METAL CHIP	100 5% 1/10W	R3322	1-218-662-11	METAL CHIP	56 0.50% 1/10W
R3079	1-216-821-11	METAL CHIP	1K 5% 1/10W	R3323	1-216-825-11	METAL CHIP	2.2K 5% 1/10W
R3089	1-216-864-11	SHORT CHIP		R3324	1-216-827-11	METAL CHIP	3.3K 5% 1/10W
R3091	1-216-825-11	METAL CHIP	2.2K 5% 1/10W	R3325	1-216-827-11	METAL CHIP	3.3K 5% 1/10W
R3092	1-216-825-11	METAL CHIP	2.2K 5% 1/10W	R3326	1-216-825-11	METAL CHIP	2.2K 5% 1/10W
R3095	1-216-845-11	METAL CHIP	100K 5% 1/10W	R3327	1-216-835-11	METAL CHIP	15K 5% 1/10W
R3096	1-216-817-11	METAL CHIP	470 5% 1/10W	R3328	1-216-864-11	SHORT CHIP	
R3097	1-216-845-11	METAL CHIP	100K 5% 1/10W	R3329	1-216-815-11	METAL CHIP	330 5% 1/10W
R3098	1-216-805-11	METAL CHIP	47 5% 1/10W	R3330	1-216-815-11	METAL CHIP	330 5% 1/10W
R3099	1-216-805-11	METAL CHIP	47 5% 1/10W	R3331	1-216-841-11	METAL CHIP	47K 5% 1/10W
R3100	1-216-809-11	METAL CHIP	100 5% 1/10W	R3332	1-218-709-11	METAL CHIP	5.1K 0.50% 1/10W
				R3333	1-216-864-11	SHORT CHIP	



REF.NO.	PART NO.	DESCRIPTION	VALUES			REF.NO.	PART NO.	DESCRIPTION	VALUES		
R3334	1-216-809-11	METAL CHIP	100	5%	1/10W	R3383	1-216-817-11	METAL CHIP	470	5%	1/10W
R3335	1-216-833-11	METAL CHIP	10K	5%	1/10W	R3384	1-216-809-11	METAL CHIP	100	5%	1/10W
R3337	1-216-820-11	METAL CHIP	820	5%	1/10W	R3410	1-216-833-11	METAL CHIP	10K	5%	1/10W
R3338	1-216-821-11	METAL CHIP	1K	5%	1/10W	R3421	1-216-864-11	SHORT CHIP			
R3339	1-216-855-11	METAL CHIP	680K	5%	1/10W	R3422	1-216-864-11	SHORT CHIP			
R3340	1-216-855-11	METAL CHIP	680K	5%	1/10W	R3423	1-216-813-11	METAL CHIP	220	5%	1/10W
R3341	1-216-813-11	METAL CHIP	220	5%	1/10W	R3428	1-216-803-11	METAL CHIP	33	5%	1/10W
R3342	1-218-705-11	METAL CHIP	3.6K	0.50%	1/10W	R3429	1-216-823-11	METAL CHIP	1.5K	5%	1/10W
R3343	1-216-809-11	METAL CHIP	100	5%	1/10W	R3432	1-216-815-11	METAL CHIP	330	5%	1/10W
R3344	1-216-853-11	METAL CHIP	470K	5%	1/10W	R3434	1-216-809-11	METAL CHIP	100	5%	1/10W
R3345	1-218-704-11	METAL CHIP	3.3K	0.50%	1/10W	R3445	1-216-864-11	SHORT CHIP			
R3346	1-216-809-11	METAL CHIP	100	5%	1/10W	R3446	1-216-821-11	METAL CHIP	1K	5%	1/10W
R3347	1-216-815-11	METAL CHIP	330	5%	1/10W	R3447	1-216-819-11	METAL CHIP	680	5%	1/10W
R3348	1-216-864-11	SHORT CHIP				R3448	1-216-855-11	METAL CHIP	680K	5%	1/10W
R3349	1-218-687-11	METAL CHIP	620	0.50%	1/10W	R3452	1-216-864-11	SHORT CHIP			
R3350	1-216-814-11	METAL CHIP	270	5%	1/10W	R3454	1-216-825-11	METAL CHIP	2.2K	5%	1/10W
R3351	1-216-825-11	METAL CHIP	2.2K	5%	1/10W	R3460	1-216-833-11	METAL CHIP	10K	5%	1/10W
R3352	1-216-853-11	METAL CHIP	470K	5%	1/10W	R3461	1-216-833-11	METAL CHIP	10K	5%	1/10W
R3353	1-216-837-11	METAL CHIP	22K	5%	1/10W	R3464	1-216-821-11	METAL CHIP	1K	5%	1/10W
R3354	1-216-813-11	METAL CHIP	220	5%	1/10W	R3465	1-216-821-11	METAL CHIP	1K	5%	1/10W
R3355	1-216-821-11	METAL CHIP	1K	5%	1/10W	R3467	1-216-821-11	METAL CHIP	1K	5%	1/10W
R3356	1-216-819-11	METAL CHIP	680	5%	1/10W	R3470	1-216-809-11	METAL CHIP	100	5%	1/10W
R3357	1-218-676-11	METAL CHIP	220	0.50%	1/10W	R3471	1-216-821-11	METAL CHIP	1K	5%	1/10W
R3358	1-218-676-11	METAL CHIP	220	0.50%	1/10W	R3472	1-216-801-11	METAL CHIP	22	5%	1/10W
R3359	1-218-676-11	METAL CHIP	220	0.50%	1/10W	R3475	1-216-809-11	METAL CHIP	100	5%	1/10W
R3360	1-216-827-11	METAL CHIP	3.3K	5%	1/10W	R3476	1-216-821-11	METAL CHIP	1K	5%	1/10W
R3361	1-216-825-11	METAL CHIP	2.2K	5%	1/10W	R3477	1-218-701-11	METAL CHIP	2.4K	0.50%	1/10W
R3364	1-216-864-11	SHORT CHIP				R3478	1-216-821-11	METAL CHIP	1K	5%	1/10W
R3365	1-216-827-11	METAL CHIP	3.3K	5%	1/10W	R3483	1-218-701-11	METAL CHIP	2.4K	0.50%	1/10W
R3366	1-216-825-11	METAL CHIP	2.2K	5%	1/10W	R3484	1-216-821-11	METAL CHIP	1K	5%	1/10W
R3367	1-216-803-11	METAL CHIP	33	5%	1/10W	R3485	1-216-821-11	METAL CHIP	1K	5%	1/10W
R3369	1-216-864-11	SHORT CHIP				R3486	1-216-801-11	METAL CHIP	22	5%	1/10W
R3371	1-218-686-11	METAL CHIP	560	0.50%	1/10W	R3489	1-216-864-11	SHORT CHIP			
R3372	1-216-817-11	METAL CHIP	470	5%	1/10W	R3490	1-216-864-11	SHORT CHIP			
R3373	1-216-817-11	METAL CHIP	470	5%	1/10W	R3491	1-216-821-11	METAL CHIP	1K	5%	1/10W
R3374	1-216-809-11	METAL CHIP	100	5%	1/10W	R3492	1-216-821-11	METAL CHIP	1K	5%	1/10W
R3375	1-218-686-11	METAL CHIP	560	0.50%	1/10W	R3493	1-218-701-11	METAL CHIP	2.4K	0.50%	1/10W
R3376	1-218-710-11	METAL CHIP	5.6K	0.50%	1/10W	R3495	1-216-821-11	METAL CHIP	1K	5%	1/10W
R3377	1-216-817-11	METAL CHIP	470	5%	1/10W	R3496	1-216-801-11	METAL CHIP	22	5%	1/10W
R3378	1-216-817-11	METAL CHIP	470	5%	1/10W	R3497	1-216-829-11	METAL CHIP	4.7K	5%	1/10W
R3379	1-216-809-11	METAL CHIP	100	5%	1/10W	R3498	1-216-818-11	METAL CHIP	560	5%	1/10W
R3380	1-218-686-11	METAL CHIP	560	0.50%	1/10W	R3499	1-216-821-11	METAL CHIP	1K	5%	1/10W
R3381	1-218-710-11	METAL CHIP	5.6K	0.50%	1/10W	R3501	1-216-821-11	METAL CHIP	1K	5%	1/10W
R3382	1-216-864-11	SHORT CHIP				R3502	1-216-821-11	METAL CHIP	1K	5%	1/10W

NOTE: The components identified by shading and \triangle mark are critical for safety. Replace only with part number specified.

NOTE: Les composants identifiés par un trame et une marque \triangle sont critiques pour la sécurité. Ne les remplacer que par une pièce portant le numéro spécifique.



REF.NO.	PART NO.	DESCRIPTION	VALUES			REF.NO.	PART NO.	DESCRIPTION	VALUES		
C8061	1-107-826-11	CERAMIC CHIP	0.1μF	10%	16V	C8106	1-107-826-11	CERAMIC CHIP	0.1μF	10%	16V
C8062	1-162-970-11	CERAMIC CHIP	0.01μF	10%	25V	C8107	1-136-187-11	MYLAR	0.047μF	10%	250V
C8063	1-107-826-11	CERAMIC CHIP	0.1μF	10%	16V	C8108	1-126-964-11	ELECT	10μF	20%	50V
C8064	1-107-636-11	ELECT	10μF	20%	160V	C8109	1-162-924-11	CERAMIC CHIP	56pF	5%	50V
C8065	1-106-383-00	MYLAR	0.047μF	10%	200V	C8110	1-126-960-11	ELECT	1μF	20%	50V
C8066	1-162-970-11	CERAMIC CHIP	0.01μF	10%	25V	C8111	1-126-960-11	ELECT	1μF	20%	50V
C8067	1-104-665-11	ELECT	100μF	20%	25V	C8113	1-130-495-00	MYLAR	0.1μF	5%	50V
C8068	1-162-318-11	CERAMIC	0.001μF	10%	500V	C8114	1-125-473-11	ELECT(BLOCK)	1000μF	20%	160V
C8069	1-162-970-11	CERAMIC CHIP	0.01μF	10%	25V	C8115	1-107-826-11	CERAMIC CHIP	0.1μF	10%	16V
C8070	1-126-964-11	ELECT	10μF	20%	50V	C8116	1-107-826-11	CERAMIC CHIP	0.1μF	10%	16V
C8071	1-126-964-11	ELECT	10μF	20%	50V	C8117	1-162-318-11	CERAMIC	0.001μF	10%	500V
C8072	1-126-964-11	ELECT	10μF	20%	50V	C8118	1-136-189-00	MYLAR	0.1μF	10%	250V
C8073	1-162-970-11	CERAMIC CHIP	0.01μF	10%	25V	C8120	1-107-826-11	CERAMIC CHIP	0.1μF	10%	16V
C8074	1-104-665-11	ELECT	100μF	20%	25V	C8121	1-115-349-51	CERAMIC	0.01μF		2KV
C8075	1-162-970-11	CERAMIC CHIP	0.01μF	10%	25V	C8122	1-126-934-11	ELECT	220μF	20%	16V
C8076	1-128-551-11	ELECT	22μF	20%	63V	C8123	1-107-444-11	CERAMIC	100pF	5%	2KV
C8077	1-162-970-11	CERAMIC CHIP	0.01μF	10%	25V	\triangle C8124	1-117-642-11	FILM	8200pF	3%	1.2KV
C8078	1-115-416-11	CERAMIC CHIP	0.001μF	5%	25V	C8125	1-107-826-11	CERAMIC CHIP	0.1μF	10%	16V
C8079	1-126-964-11	ELECT	10μF	20%	50V	C8126	1-106-357-00	MYLAR	0.0039μF	99%	200V
C8080	1-126-964-11	ELECT	10μF	20%	50V	C8127	1-126-942-61	ELECT	1000μF	20%	25V
C8081	1-115-416-11	CERAMIC CHIP	0.001μF	5%	25V	C8129	1-137-150-11	FILM	.01μF	5%	100V
C8082	1-165-176-11	CERAMIC CHIP	0.047μF	10%	16V	C8131	1-128-582-11	ELECT	10μF	20%	100V
C8083	1-130-495-00	MYLAR	.1μF	5%	50V	C8132	1-126-927-11	ELECT	2200μF	20%	10V
C8084	1-130-992-11	FILM	0.022μF	5%	50V	C8133	1-107-649-11	ELECT	2.2μF	20%	250V
C8085	1-162-924-11	CERAMIC CHIP	56pF	5%	50V	C8135	1-117-813-11	FILM	0.75μF	5%	250V
C8086	1-162-970-11	CERAMIC CHIP	0.01μF	10%	25V	C8136	1-130-495-00	MYLAR	0.1μF	5%	50V
C8087	1-126-960-11	ELECT	1μF	20%	50V	C8137	1-126-927-11	ELECT	2200μF	20%	10V
C8088	1-126-964-11	ELECT	10μF	20%	50V	C8138	1-162-964-11	CERAMIC CHIP	0.001μF	10%	50V
\triangle C8089	1-104-332-11	CERAMIC	470pF	10%	2KV	C8139	1-126-964-11	ELECT	10μF	20%	50V
C8090	1-126-960-11	ELECT	1μF	20%	50V	C8140	1-102-030-00	CERAMIC	330pF	10%	500V
C8091	1-104-665-11	ELECT	100μF	20%	25V	C8141	1-162-927-11	CERAMIC CHIP	100pF	5%	50V
C8092	1-117-640-11	FILM	6800pF	3%	1.2KV	C8142	1-117-664-11	FILM	0.27μF	5%	250V
C8093	1-107-648-91	ELECT	100μF	20%	200V	C8143	1-109-889-11	ELECT	1μF	20%	50V
C8094	1-126-947-11	ELECT	47μF	20%	35V	C8153	1-126-960-11	ELECT	1μF	20%	50V
C8095	1-162-970-11	CERAMIC CHIP	0.01μF	10%	25V	C8156	1-107-636-11	ELECT	10μF	20%	160V
C8096	1-136-684-51	FILM	0.0022μF	2.00%	100V	C8158	1-107-826-11	CERAMIC CHIP	0.1μF	10%	16V
C8097	1-162-131-11	CERAMIC	220pF	10%	2KV	C8159	1-106-383-00	MYLAR	0.047μF	10%	200V
C8098	1-162-131-11	CERAMIC	220pF	10%	2KV	C8160	1-127-715-91	CERAMIC CHIP	0.22μF	10%	16V
C8099	1-115-416-11	CERAMIC CHIP	0.001μF	5%	25V	C8162	1-162-318-11	CERAMIC	0.001μF	10%	500V
C8100	1-104-665-11	ELECT	100μF	20%	25V	C8163	1-126-960-11	ELECT	1μF	20%	50V
C8102	1-162-318-11	CERAMIC	0.001μF	10%	500V	CONNECTOR					
C8103	1-126-964-11	ELECT	10μF	20%	50V	* CN8002	1-779-890-11	CONNECTOR, BOARD TO BOARD	10P		
C8104	1-162-965-11	CERAMIC CHIP	0.0015μF	10%	50V	* CN8003	1-691-135-11	PIN, CONNECTOR (PC BOARD)	4P		
C8105	1-107-826-11	CERAMIC CHIP	0.1μF	10%	16V						







REF.NO.	PART NO.	DESCRIPTION	VALUES	REF.NO.	PART NO.	DESCRIPTION	VALUES
* CN8004	1-779-890-11	CONNECTOR, BOARD TO BOARD	10P	D8032	8-719-302-43	DIODE	EL1Z
* CN8005	1-779-890-11	CONNECTOR, BOARD TO BOARD	10P	D8033	8-719-028-72	DIODE	RGP02-17EL-6433
* CN8006	1-779-890-11	CONNECTOR, BOARD TO BOARD	10P	D8036	8-719-110-39	DIODE	RD15ESB1
* CN8007	1-564-506-11	PLUG, CONNECTOR	3P	D8037	8-719-028-45	DIODE	D2L20U
* CN8008	1-564-506-11	PLUG, CONNECTOR	3P	D8038	8-719-302-43	DIODE	EL1Z
* CN8009	1-564-506-11	PLUG, CONNECTOR	3P	D8039	8-719-028-72	DIODE	RGP02-17EL-6433
* CN8010	1-564-507-11	PLUG, CONNECTOR	4P	D8043	8-719-991-33	DIODE	1SS133T-77
* CN8011	1-564-507-11	PLUG, CONNECTOR	4P	D8045	8-719-908-03	DIODE	GP08D
* CN8012	1-564-507-11	PLUG, CONNECTOR	4P	D8046	8-719-991-33	DIODE	1SS133T-77
* CN8013	1-766-177-11	PIN, CONNECTOR (PC BOARD)	9P	D8047	8-719-991-33	DIODE	1SS133T-77
* CN8015	1-506-371-00	PIN, CONNECTOR	2P	D8050	8-719-988-61	DIODE	1SS355TE-17
* CN8016	1-564-507-11	PLUG, CONNECTOR	4P	FERRITE BEAD			
CN8018	1-580-689-11	PIN, CONNECTOR (PC BOARD)	4P	FB8001	1-469-578-11	FERRITE	1.1μH
* CN8019	1-580-689-11	PIN, CONNECTOR (PC BOARD)	4P	FB8002	1-469-578-11	FERRITE	1.1μH
* CN8020	1-580-689-11	PIN, CONNECTOR (PC BOARD)	4P	FB8005	1-469-869-21	FERRITE	0μH
* CN8022	1-564-510-11	PLUG, CONNECTOR	7P	FB8006	1-469-869-21	FERRITE	0μH
* CN8023	1-564-507-11	PLUG, CONNECTOR	4P	FB8014	1-469-869-21	FERRITE	0μH
DIODE				FB8015	1-469-869-21	FERRITE	0μH
D8001	8-719-109-88	DIODE	RD5.6ESB1	FB8016	1-469-869-21	FERRITE	0μH
D8002	8-719-110-53	DIODE	RD20ESB2	FB8017	1-469-869-21	FERRITE	0μH
D8003	8-719-110-56	DIODE	RD22ESB1	FB8018	1-469-869-21	FERRITE	0μH
D8004	8-719-908-03	DIODE	GP08D	FB8021	1-469-578-11	FERRITE	1.1μH
D8005	8-719-991-33	DIODE	1SS133T-77	FB8022	1-469-579-11	FERRITE	0.45μH
D8006	8-719-991-33	DIODE	1SS133T-77	FB8023	1-469-579-11	FERRITE	0.45μH
D8008	8-719-991-33	DIODE	1SS133T-77	FB8024	1-469-869-21	FERRITE	0μH
D8010	8-719-991-33	DIODE	1SS133T-77	IC			
D8011	8-719-991-33	DIODE	1SS133T-77	IC8001	8-749-019-08	IC	STK392-560
D8012	8-719-991-33	DIODE	1SS133T-77	IC8002	8-749-019-08	IC	STK392-560
D8013	8-719-109-84	DIODE	RD5.1ESB1	IC8003	8-759-593-33	IC	LA78045
D8014	8-719-109-84	DIODE	RD5.1ESB1	IC8004	8-759-647-17	IC	UPC2912HF
D8015	8-719-991-33	DIODE	1SS133T-77	IC8005	8-759-585-82	IC	BA9759F-E2
D8016	8-719-991-33	DIODE	1SS133T-77	IC8006	8-759-700-07	IC	NJM2903M
D8019	8-719-991-33	DIODE	1SS133T-77	IC8007	8-759-700-07	IC	NJM2903M
D8020	8-719-991-33	DIODE	1SS133T-77	IC8008	8-759-585-82	IC	BA9759F-E2
D8022	8-719-991-33	DIODE	1SS133T-77	IC8009	8-759-803-42	IC	LA6500-FA
D8023	8-719-991-33	DIODE	1SS133T-77	IC8012	8-759-701-01	IC	NJM2904M
D8024	8-719-110-39	DIODE	RD15ESB1	COIL			
D8025	8-719-991-33	DIODE	1SS133T-77	L8001	1-412-533-21	INDUCTOR	47μH
D8026	8-719-109-88	DIODE	RD5.6ESB1	L8002	1-412-533-21	INDUCTOR	47μH
D8027	8-719-028-45	DIODE	D2L20U	L8003	1-412-525-31	INDUCTOR	10μH
D8028	8-719-110-41	DIODE	RD15ESB2	L8004	1-412-533-21	INDUCTOR	47μH
D8029	8-719-027-43	DIODE	S2L20μF	L8005	1-412-533-21	INDUCTOR	47μH
D8030	8-719-027-43	DIODE	S2L20μF				

NOTE: The components identified by shading and  mark are critical for safety. Replace only with part number specified.

NOTE: Les composants identifiés par un trame et une  marque sont critiques pour la sécurité. Ne les remplacer que par une pièce portant le numéro spécifique.



REF.NO.	PART NO.	DESCRIPTION	VALUES	REF.NO.	PART NO.	DESCRIPTION	VALUES
L8006	1-412-525-31	INDUCTOR	10µH	Q8015	8-729-120-28	TRANSISTOR	2SC1623-L5L6
L8007	1-412-533-21	INDUCTOR	47µH	Q8016	8-729-120-28	TRANSISTOR	2SC1623-L5L6
L8008	1-412-533-21	INDUCTOR	47µH	Q8019	8-729-026-49	TRANSISTOR	2SA1037AK-T146-R
L8009	1-412-525-31	INDUCTOR	10µH	Q8020	8-729-120-28	TRANSISTOR	2SC1623-L5L6
L8010	1-414-187-11	INDUCTOR	47µH	Q8021	8-729-120-28	TRANSISTOR	2SC1623-L5L6
L8011	1-414-856-11	INDUCTOR	10µH	Q8022	8-729-120-28	TRANSISTOR	2SC1623-L5L6
L8012	1-414-187-11	INDUCTOR	47µH	Q8023	8-729-048-47	TRANSISTOR	2SC2688(5)-LK
L8013	1-414-856-11	INDUCTOR	10µH	Q8024	6-550-144-01	TRANSISTOR	2SC5778-YB
L8014	1-414-189-31	INDUCTOR	100µH	Q8027	6-550-153-01	TRANSISTOR	FQPF12P20XDTU
L8015	1-414-189-31	INDUCTOR	100µH	Q8028	8-729-120-28	TRANSISTOR	2SC1623-L5L6
L8016	1-412-537-31	INDUCTOR	100µH	Q8029	8-729-120-28	TRANSISTOR	2SC1623-L5L6
L8017	1-414-856-11	INDUCTOR	10µH	Q8030	8-729-026-49	TRANSISTOR	2SA1037AK-T146-R
L8018	1-406-667-11	INDUCTOR	220µH	Q8031	8-729-120-28	TRANSISTOR	2SC1623-L5L6
L8019	1-456-109-11	COIL,HORIZONTAL LINEARITY(HLC)		Q8035	6-550-153-01	TRANSISTOR	FQPF12P20XDTU
L8020	1-412-525-31	INDUCTOR	10µH	Q8039	8-729-048-47	TRANSISTOR	2SC2688(5)-LK
L8021	1-406-659-11	INDUCTOR	10µH	Q8041	8-729-026-49	TRANSISTOR	2SA1037AK-T146-R
L8022	1-412-552-11	INDUCTOR	2.2MH	Q8042	8-729-048-47	TRANSISTOR	2SC2688(5)-LK
L8025	1-414-856-11	INDUCTOR	10µH	Q8043	6-550-144-01	TRANSISTOR	2SC5778-YB
L8026	1-414-856-11	INDUCTOR	10µH	Q8101	8-729-026-49	TRANSISTOR	2SA1037AK-T146-R
L8033	1-414-856-11	INDUCTOR	10µH				
NEON LAMP				RESISTOR			
 NL8001	1-517-778-21	LAMP, NEON		R8001	1-216-825-11	METAL CHIP	2.2K 5% 1/10W
IC LINK				R8002	1-216-809-11	METAL CHIP	100 5% 1/10W
 PS8001	1-533-595-31	IC LINK	3.15A 90V	R8003	1-216-809-11	METAL CHIP	100 5% 1/10W
 PS8002	1-533-595-31	IC LINK	3.15A 90V	R8004	1-216-809-11	METAL CHIP	100 5% 1/10W
 PS8003	1-533-595-31	IC LINK	3.15A 90V	R8005	1-215-875-11	METAL OXIDE	10K 5% 1W
 PS8004	1-533-595-31	IC LINK	3.15A 90V	R8007	1-216-809-11	METAL CHIP	100 5% 1/10W
 PS8005	1-533-595-31	IC LINK	3.15A 90V	R8008	1-216-809-11	METAL CHIP	100 5% 1/10W
 PS8006	1-533-595-31	IC LINK	3.15A 90V	R8009	1-216-809-11	METAL CHIP	100 5% 1/10W
 PS8007	1-533-594-31	IC LINK	2.5A 90V	R8010	1-260-131-11	CARBON	470K 5% 1/2W
 PS8008	1-532-685-00	IC LINK	0.8A 50V	R8011	1-216-829-11	METAL CHIP	4.7K 5% 1/10W
TRANSISTOR				R8012	1-216-829-11	METAL CHIP	4.7K 5% 1/10W
Q8001	8-729-120-28	TRANSISTOR	2SC1623-L5L6	R8013	1-218-710-11	METAL CHIP	5.6K 0.50% 1/10W
Q8002	6-550-659-01	TRANSISTOR	2SC4634LS-YB11	R8014	1-218-709-11	METAL CHIP	5.1K 0.50% 1/10W
Q8003	8-729-026-49	TRANSISTOR	2SA1037AK-T146-R	R8015	1-216-837-11	METAL CHIP	22K 5% 1/10W
Q8004	8-729-026-49	TRANSISTOR	2SA1037AK-T146-R	R8016	1-216-829-11	METAL CHIP	4.7K 5% 1/10W
Q8007	8-729-046-80	TRANSISTOR	2SC4634LS-CB11	R8017	1-216-829-11	METAL CHIP	4.7K 5% 1/10W
Q8008	8-729-207-89	TRANSISTOR	2SA1358-Y	R8018	1-216-821-11	METAL CHIP	1K 5% 1/10W
Q8009	8-729-207-82	TRANSISTOR	2SC3421-Y	R8019	1-218-712-11	METAL CHIP	6.8K 0.50% 1/10W
Q8010	8-729-120-28	TRANSISTOR	2SC1623-L5L6	R8020	1-216-829-11	METAL CHIP	4.7K 5% 1/10W
Q8011	8-729-026-49	TRANSISTOR	2SA1037AK-T146-R	R8021	1-216-833-11	METAL CHIP	10K 5% 1/10W
Q8014	8-729-120-28	TRANSISTOR	2SC1623-L5L6	R8022	1-216-839-11	METAL CHIP	33K 5% 1/10W
				R8023	1-216-833-11	METAL CHIP	10K 5% 1/10W
				R8024	1-216-833-11	METAL CHIP	10K 5% 1/10W



REF.NO.	PART NO.	DESCRIPTION	VALUES			REF.NO.	PART NO.	DESCRIPTION	VALUES			
R8025	1-216-829-11	METAL CHIP	4.7K	5%	1/10W	R8073	1-214-808-11	METAL	4.7	1%	1/2W	
R8026	1-216-829-11	METAL CHIP	4.7K	5%	1/10W	R8075	1-214-808-11	METAL	4.7	1%	1/2W	
R8029	1-216-829-11	METAL CHIP	4.7K	5%	1/10W	R8076	1-216-829-11	METAL CHIP	4.7K	5%	1/10W	
R8030	1-215-903-11	METAL OXIDE	68K	5%	2W	R8077	1-216-829-11	METAL CHIP	4.7K	5%	1/10W	
R8031	1-216-829-11	METAL CHIP	4.7K	5%	1/10W	R8078	1-214-808-11	METAL	4.7	1%	1/2W	
R8032	1-216-821-11	METAL CHIP	1K	5%	1/10W	R8079	1-214-808-11	METAL	4.7	1%	1/2W	
R8033	1-216-833-11	METAL CHIP	10K	5%	1/10W	R8080	1-216-353-00	METAL OXIDE	2.2	5%	1W	
R8034	1-216-833-11	METAL CHIP	10K	5%	1/10W	R8081	1-214-808-11	METAL	4.7	1%	1/2W	
R8035	1-218-692-11	METAL CHIP	1K	0.50%	1/10W	R8082	1-214-808-11	METAL	4.7	1%	1/2W	
R8036	1-214-800-11	METAL	2.2	1%	1/2W	R8083	1-216-821-11	METAL CHIP	1K	5%	1/10W	
R8037	1-215-903-11	METAL OXIDE	68K	5%	2W	R8084	1-216-833-11	METAL CHIP	10K	5%	1/10W	
R8038	1-216-809-11	METAL CHIP	100	5%	1/10W	R8085	1-214-808-11	METAL	4.7	1%	1/2W	
R8039	1-214-800-11	METAL	2.2	1%	1/2W	R8086	1-214-808-11	METAL	4.7	1%	1/2W	
R8040	1-215-913-11	METAL OXIDE	220	5%	3W	R8087	1-249-385-11	CARBON	2.2	5%	1/4W	
R8041	1-218-709-11	METAL CHIP	5.1K	0.50%	1/10W	R8088	1-249-385-11	CARBON	2.2	5%	1/4W	
R8042	1-216-826-11	METAL CHIP	2.7K	5%	1/10W	R8089	1-214-808-11	METAL	4.7	1%	1/2W	
R8043	1-218-740-11	METAL CHIP	100K	0.50%	1/10W	R8090	1-214-808-11	METAL	4.7	1%	1/2W	
R8044	1-218-712-11	METAL CHIP	6.8K	0.50%	1/10W	R8091	1-214-808-11	METAL	4.7	1%	1/2W	
R8045	1-214-808-11	METAL	4.7	1%	1/2W	R8092	1-214-808-11	METAL	4.7	1%	1/2W	
R8046	1-214-808-11	METAL	4.7	1%	1/2W	R8093	1-214-808-11	METAL	4.7	1%	1/2W	
R8047	1-215-857-71	METAL OXIDE	10	5%	1W	R8094	1-214-808-11	METAL	4.7	1%	1/2W	
R8048	1-414-189-31	INDUCTOR	100µH			R8095	1-216-801-11	METAL CHIP	22	5%	1/10W	
R8049	1-414-189-31	INDUCTOR	100µH			R8096	1-216-801-11	METAL CHIP	22	5%	1/10W	
R8050	1-216-833-11	METAL CHIP	10K	5%	1/10W	R8097	1-214-808-11	METAL	4.7	1%	1/2W	
R8051	1-214-808-11	METAL	4.7	1%	1/2W	R8098	1-214-808-11	METAL	4.7	1%	1/2W	
R8053	1-214-808-11	METAL	4.7	1%	1/2W	R8099	1-218-740-11	METAL CHIP	100K	0.50%	1/10W	
R8055	1-218-748-11	METAL CHIP	220K	0.50%	1/10W	R8100	1-216-475-11	METAL OXIDE	120	5%	3W	
R8056	1-216-829-11	METAL CHIP	4.7K	5%	1/10W	R8101	1-216-475-11	METAL OXIDE	120	5%	3W	
R8057	1-216-829-11	METAL CHIP	4.7K	5%	1/10W	R8102	1-218-738-11	METAL CHIP	82K	0.50%	1/10W	
R8058	1-216-809-11	METAL CHIP	100	5%	1/10W	R8103	1-216-816-11	METAL CHIP	390	5%	1/10W	
R8059	1-214-808-11	METAL	4.7	1%	1/2W	R8104	1-216-832-11	METAL CHIP	8.2K	5%	1/10W	
R8060	1-214-808-11	METAL	4.7	1%	1/2W	R8105	1-214-808-11	METAL	4.7	1%	1/2W	
R8061	1-216-390-11	METAL OXIDE	1.2	5%	3W	R8106	1-214-808-11	METAL	4.7	1%	1/2W	
		(SERIAL # 8,700,001 AND UP)				R8109	1-216-814-11	METAL CHIP	270	5%	1/10W	
	R8061	1-216-392-11	METAL OXIDE	1.8	5%	3W	R8110	1-247-852-11	CARBON	7.5K	5%	1/4W
		(SERIAL # 8,000,001 TO 8,700,000)				R8111	1-216-819-11	METAL CHIP	680	5%	1/10W	
R8062	1-260-107-11	CARBON	4.7K	5%	1/2W	R8112	1-216-824-11	METAL CHIP	1.8K	5%	1/10W	
R8063	1-214-808-11	METAL	4.7	1%	1/2W	R8113	1-216-475-11	METAL OXIDE	120	5%	3W	
R8064	1-214-808-11	METAL	4.7	1%	1/2W	R8114	1-216-475-11	METAL OXIDE	120	5%	3W	
R8065	1-260-328-11	CARBON	1K	5%	1/2W	R8115	1-216-475-11	METAL OXIDE	120	5%	3W	
R8066	1-214-808-11	METAL	4.7	1%	1/2W	R8116	1-216-475-11	METAL OXIDE	120	5%	3W	
R8067	1-214-808-11	METAL	4.7	1%	1/2W	R8117	1-216-833-11	METAL CHIP	10K	5%	1/10W	
R8068	1-216-809-11	METAL CHIP	100	5%	1/10W	R8118	1-216-833-11	METAL CHIP	10K	5%	1/10W	
R8069	1-214-808-11	METAL	4.7	1%	1/2W	R8119	1-216-833-11	METAL CHIP	10K	5%	1/10W	
R8070	1-214-808-11	METAL	4.7	1%	1/2W	R8120	1-216-833-11	METAL CHIP	10K	5%	1/10W	
R8071	1-215-381-00	METAL	22	1%	1/4W							









REF.NO.	PART NO.	DESCRIPTION	VALUES			REF.NO.	PART NO.	DESCRIPTION	VALUES		
R8121	1-216-809-11	METAL CHIP	100	5%	1/10W	R8170	1-218-716-11	METAL CHIP	10K	0.50%	1/10W
R8123	1-216-821-11	METAL CHIP	1K	5%	1/10W	R8171	1-216-809-11	METAL CHIP	100	5%	1/10W
R8124	1-249-377-11	CARBON	0.47	5%	1/4W	R8172	1-249-405-11	CARBON	100	5%	1/4W
R8125	1-216-816-11	METAL CHIP	390	5%	1/10W	R8173	1-216-845-11	METAL CHIP	100K	5%	1/10W
R8126	1-216-823-11	METAL CHIP	1.5K	5%	1/10W	R8174	1-249-425-11	CARBON	4.7K	5%	1/4W
R8128	1-216-833-11	METAL CHIP	10K	5%	1/10W	R8176	1-218-740-11	METAL CHIP	100K	0.50%	1/10W
R8129	1-216-825-11	METAL CHIP	2.2K	5%	1/10W	R8178	1-216-841-11	METAL CHIP	47K	5%	1/10W
R8130	1-216-825-11	METAL CHIP	2.2K	5%	1/10W	R8179	1-414-189-31	INDUCTOR	100µH		
R8131	1-216-833-11	METAL CHIP	10K	5%	1/10W	R8180	1-216-841-11	METAL CHIP	47K	5%	1/10W
R8132	1-216-833-11	METAL CHIP	10K	5%	1/10W	R8181	1-216-841-11	METAL CHIP	47K	5%	1/10W
R8133	1-215-923-00	METAL OXIDE	10K	5%	3W	R8182	1-218-748-11	METAL CHIP	220K	0.50%	1/10W
R8134	1-215-873-00	METAL OXIDE	4.7K	5%	1W	R8183	1-218-748-11	METAL CHIP	220K	0.50%	1/10W
R8135	1-215-923-00	METAL OXIDE	10K	5%	3W	R8189	1-249-377-11	CARBON	0.47	5%	1/4W
R8136	1-216-833-11	METAL CHIP	10K	5%	1/10W	R8190	1-215-431-00	METAL	2.7K	1%	1/4W
R8137	1-218-740-11	METAL CHIP	100K	0.50%	1/10W	R8191	1-215-429-00	METAL	2.2K	1%	1/4W
R8138	1-216-833-11	METAL CHIP	10K	5%	1/10W	R8192	1-215-449-00	METAL	15K	1%	1/4W
R8139	1-216-827-11	METAL CHIP	3.3K	5%	1/10W	R8193	1-215-449-00	METAL	15K	1%	1/4W
R8140	1-216-833-11	METAL CHIP	10K	5%	1/10W	R8194	1-215-449-00	METAL	15K	1%	1/4W
R8141	1-216-827-11	METAL CHIP	3.3K	5%	1/10W	R8195	1-215-449-00	METAL	15K	1%	1/4W
R8142	1-216-833-11	METAL CHIP	10K	5%	1/10W	R8196	1-249-425-11	CARBON	4.7K	5%	1/4W
R8143	1-218-734-11	METAL CHIP	56K	0.50%	1/10W	R8201	1-249-397-11	CARBON	22	5%	1/4W
R8144	1-216-809-11	METAL CHIP	100	5%	1/10W	R8202	1-260-092-11	CARBON	270	5%	1/2W
R8145	1-218-716-11	METAL CHIP	10K	0.50%	1/10W	R8205	1-249-377-11	CARBON	0.47	5%	1/4W
R8146	1-218-716-11	METAL CHIP	10K	0.50%	1/10W	R8206	1-249-377-11	CARBON	0.47	5%	1/4W
R8147	1-218-710-11	METAL CHIP	5.6K	0.50%	1/10W	R8208	1-260-288-11	CARBON	0.47	5%	1/2W
R8148	1-218-740-11	METAL CHIP	100K	0.50%	1/10W	R8209	1-216-833-11	METAL CHIP	10K	5%	1/10W
R8149	1-249-401-11	CARBON	47	5%	1/4W	R8210	1-216-809-11	METAL CHIP	100	5%	1/10W
R8150	1-218-740-11	METAL CHIP	100K	0.50%	1/10W	R8211	1-215-906-11	METAL OXIDE	15	5%	3W
R8151	1-218-692-11	METAL CHIP	1K	0.50%	1/10W	R8212	1-215-907-11	METAL OXIDE	22	5%	3W
R8152	1-218-716-11	METAL CHIP	10K	0.50%	1/10W	R8213	1-216-821-11	METAL CHIP	1K	5%	1/10W
R8153	1-218-692-11	METAL CHIP	1K	0.50%	1/10W	R8216	1-216-833-11	METAL CHIP	10K	5%	1/10W
R8154	1-218-728-11	METAL CHIP	33K	0.50%	1/10W	R8217	1-216-821-11	METAL CHIP	1K	5%	1/10W
R8155	1-215-469-00	METAL	100K	1%	1/4W	R8218	1-260-123-11	CARBON	100K	5%	1/2W
R8156	1-215-469-00	METAL	100K	1%	1/4W	R8219	1-249-377-11	CARBON	0.47	5%	1/4W
R8157	1-218-738-11	METAL CHIP	82K	0.50%	1/10W	R8220	1-216-821-11	METAL CHIP	1K	5%	1/10W
R8159	1-216-833-11	METAL CHIP	10K	5%	1/10W	R8222	1-216-341-11	METAL OXIDE	0.22	5%	1W
R8161	1-216-845-11	METAL CHIP	100K	5%	1/10W	R8223	1-218-748-11	METAL CHIP	220K	0.50%	1/10W
R8163	1-216-845-11	METAL CHIP	100K	5%	1/10W	R8224	1-260-127-11	CARBON	220K	5%	1/2W
R8164	1-218-734-11	METAL CHIP	56K	0.50%	1/10W	R8225	1-260-292-11	CARBON	1	5%	1/2W
R8165	1-249-425-11	CARBON	4.7K	5%	1/4W	R8228	1-260-314-11	CARBON	68	5%	1/2W
R8166	1-218-716-11	METAL CHIP	10K	0.50%	1/10W	R8230	1-218-751-11	METAL CHIP	300K	0.50%	1/10W
R8167	1-414-189-31	INDUCTOR	100µH			R8232	1-216-341-11	METAL OXIDE	0.22	5%	1W
R8168	1-216-809-11	METAL CHIP	100	5%	1/10W	R8236	1-218-917-11	METAL CHIP	820K	0.50%	1/10W
R8169	1-216-845-11	METAL CHIP	100K	5%	1/10W	R8237	1-216-857-11	METAL CHIP	1M	5%	1/10W

NOTE: The components identified by shading and  mark are critical for safety. Replace only with part number specified.

A component identified by this  symbol indicates that it has been carefully factory-selected to satisfy regulations regarding X-ray radiation. Should replacement be required, replace only with the value originally used.

D **SR** **H2** **H1**

REF.NO.	PART NO.	DESCRIPTION	VALUES	REF.NO.	PART NO.	DESCRIPTION	VALUES
R8249	1-215-923-00	METAL OXIDE	10K 5% 3W	RESISTOR			
R8250	1-215-923-00	METAL OXIDE	10K 5% 3W	R9201	1-218-684-11	METAL CHIP	470 0.50% 1/10W
R8251	1-216-821-11	METAL CHIP	1K 5% 1/10W	R9202	1-218-684-11	METAL CHIP	470 0.50% 1/10W
R8253	1-216-816-11	METAL CHIP	390 5% 1/10W	R9203	1-218-684-11	METAL CHIP	470 0.50% 1/10W
R8254	1-216-823-11	METAL CHIP	1.5K 5% 1/10W	R9204	1-218-684-11	METAL CHIP	470 0.50% 1/10W
R8255	1-215-873-00	METAL OXIDE	4.7K 5% 1W	R9205	1-218-688-11	METAL CHIP	680 0.50% 1/10W
R8256	1-249-401-11	CARBON	47 5% 1/4W	R9206	1-218-688-11	METAL CHIP	680 0.50% 1/10W
R8258	1-216-833-11	METAL CHIP	10K 5% 1/10W	R9207	1-218-692-11	METAL CHIP	1K 0.50% 1/10W
TRANSFORMER				R9208	1-218-696-11	METAL CHIP	1.5K 0.50% 1/10W
T8001	1-437-708-11	TRANSFORMER, FERRITE (DFT)		R9209	1-218-700-11	METAL CHIP	2.2K 0.50% 1/10W
T8002	1-437-739-11	TRANSFORMER, FERRITE (HDT)		R9210	1-218-704-11	METAL CHIP	3.3K 0.50% 1/10W
T8003	1-437-401-21	FERRITE TRANSFORMER (HOT)		R9211	1-218-712-11	METAL CHIP	6.8K 0.50% 1/10W
 T8004	1-437-399-21	TRANSFORMER, FERRITE (LOT)		SWITCH			
 T8005	1-453-285-51	FBT ASSY, NX-4006//X4P4		S9201	1-572-198-11	SWITCH, KEYBOARD	
T8006	1-437-739-11	TRANSFORMER, FERRITE (HDT)		S9202	1-572-198-11	SWITCH, KEYBOARD	
THERMISTOR				S9203	1-572-198-11	SWITCH, KEYBOARD	
TH8001	1-800-193-00	THERMISTOR		S9204	1-572-198-11	SWITCH, KEYBOARD	
VARIABLE RESISTOR				S9205	1-572-198-11	SWITCH, KEYBOARD	
  VR8001	1-225-627-91	RES, VAR, ADJ, CERMET	2K	S9206	1-572-198-11	SWITCH, KEYBOARD	
  VR8002	1-225-630-91	RES, VAR, ADJ, CERMET	20K	S9207	1-572-198-11	SWITCH, KEYBOARD	
SR				S9208	1-572-198-11	SWITCH, KEYBOARD	
*	A-1400-759-A	SR BOARD, MOUNTED		S9209	1-572-198-11	SWITCH, KEYBOARD	
CONNECTOR				S9210	1-572-198-11	SWITCH, KEYBOARD	
*	CN9901	1-564-506-11	PLUG, CONNECTOR 3P	S9211	1-572-198-11	SWITCH, KEYBOARD	
DIODE				S9212	1-572-198-11	SWITCH, KEYBOARD	
D9902	8-719-069-55	DIODE	UDZSTE-175.6B	H1			
BATTERY				*	A-1405-148-A	H1 BOARD, MOUNTED	
SB9901	1-756-295-11	BATTERY, SOLAR		CAPACITOR			
H2				C9101	1-107-826-11	CERAMIC CHIP	0.1µF 10% 16V
*	A-1405-147-A	H2 BOARD, MOUNTED		CONNECTOR			
CONNECTOR				* CN9101	1-564-508-11	PLUG, CONNECTOR	5P
* CN9201	1-564-520-11	PLUG, CONNECTOR	5P	* CN9102	1-564-506-11	PLUG, CONNECTOR	3P
* CN9202	1-564-521-11	PLUG, CONNECTOR	6P	DIODE			
IC				D9101	8-719-053-43	DIODE	SLR-325VCT31
				D9102	8-719-053-43	DIODE	SLR-325VCT31
				IC9101	8-719-066-43	DIODE	GP1U28Y



REF.NO.	PART NO.	DESCRIPTION	VALUES			REF.NO.	PART NO.	DESCRIPTION	VALUES			
RESISTOR					RESISTOR							
R9101	1-216-833-11	METAL CHIP	10K	5%	1/10W	R9400	1-216-853-11	METAL CHIP	470K	5%	1/10W	
R9102	1-216-809-11	METAL CHIP	100	5%	1/10W	R9401	1-216-853-11	METAL CHIP	470K	5%	1/10W	
R9103	1-216-813-11	METAL CHIP	220	5%	1/10W	R9402	1-218-285-11	METAL CHIP	75	5%	1/10W	
R9104	1-216-813-11	METAL CHIP	220	5%	1/10W	R9403	1-218-285-11	METAL CHIP	75	5%	1/10W	
SWITCH					RESISTOR							
S9101	1-571-532-21	SWITCH, TACTILE				R9406	1-216-821-11	METAL CHIP	1K	5%	1/10W	
					R9407 1-218-285-11 METAL CHIP 75 5% 1/10W							
					ACCESSORIES AND PACKING							
					* 4-091-919-01 BAG, PROTECTION							
					* 4-096-271-01 CARTON, INDIVIDUAL							
					* 4-091-087-01 CUSHION, LOWER							
					* 4-091-086-01 CUSHION, UPPER							
					4-094-605-11 MANUAL, INSTRUCTION							
					4-094-605-21 MANUAL, INSTRUCTION							
					4-094-605-31 MANUAL, INSTRUCTION							
					* 4-091-920-01 SHEET, PROTECTION							
					* 4-096-700-01 TRAY							
					REMOTE COMMANDER							
					1-476-864-11 REMOTE COMMANDER (RM-Y909)							
					4-081-888-01 BATTERY COVER (FOR RM-Y909)							
H4												
*	A-1405-149-A	H4 BOARD, MOUNTED										
CAPACITOR												
C9400	1-126-964-11	ELECT	10μF	20%	50V							
C9401	1-126-964-11	ELECT	10μF	20%	50V							
C9402	1-125-891-11	CERAMIC CHIP	0.47μF	10%	10V							
C9403	1-163-021-91	CERAMIC CHIP	0.01μF	10%	50V							
C9405	1-125-891-11	CERAMIC CHIP	0.47μF	10%	10V							
CONNECTOR												
*	CN9401	1-564-526-11	PLUG, CONNECTOR	11P								
DIODE												
D9400	8-719-110-17	DIODE	RD10ESB2									
D9401	8-719-110-17	DIODE	RD10ESB2									
D9402	8-719-110-17	DIODE	RD10ESB2									
D9403	8-719-110-17	DIODE	RD10ESB2									
D9404	8-719-110-17	DIODE	RD10ESB2									
D9405	8-719-110-17	DIODE	RD10ESB2									
JACK												
J9401	1-770-361-11	TERMINAL BLOCK, S										

In an effort to reduce the size of this pdf file the tiled schematics are not attached to this Service Manual. To receive a complete set of the tiled schematics for this manual please submit a request to:

Service_Promotion@am.sony.com.

COLOR REAR VIDEO PROJECTION

SONY®